



**STEP**  
FOLDING LADDER

E-step is the new electrical ladder that allows easy access to enter and exit the water.



100% Made in Italy its a pantograph system is inspired by the trams of the Milanese metropolis.





E- Step is available in 2 versions with 3 and 4 steps.

The steps have a variable width, which allows a comfortable descent and ascent when approaching the platform.

E-step is a motorized electric folding ladder with minimum dimension and weights, especially when in close position.

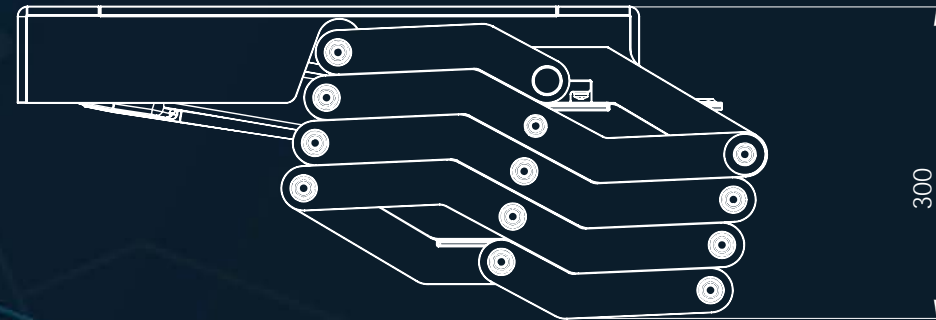
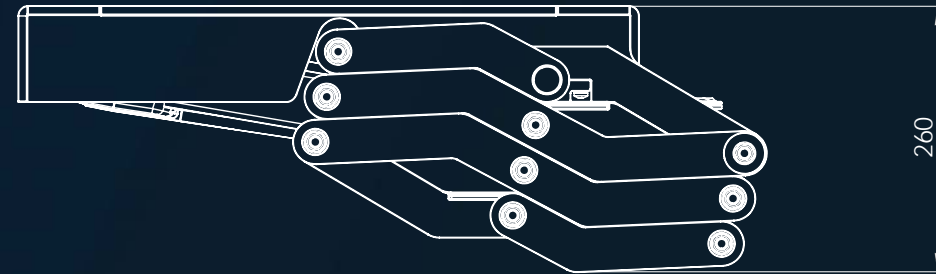

Thanks to the special shape of its arms, E-Step opens with a greater angle than other scissor folding systems used in other sector (e.g. camper).

Other scissor folding system

45°

E-step

60°

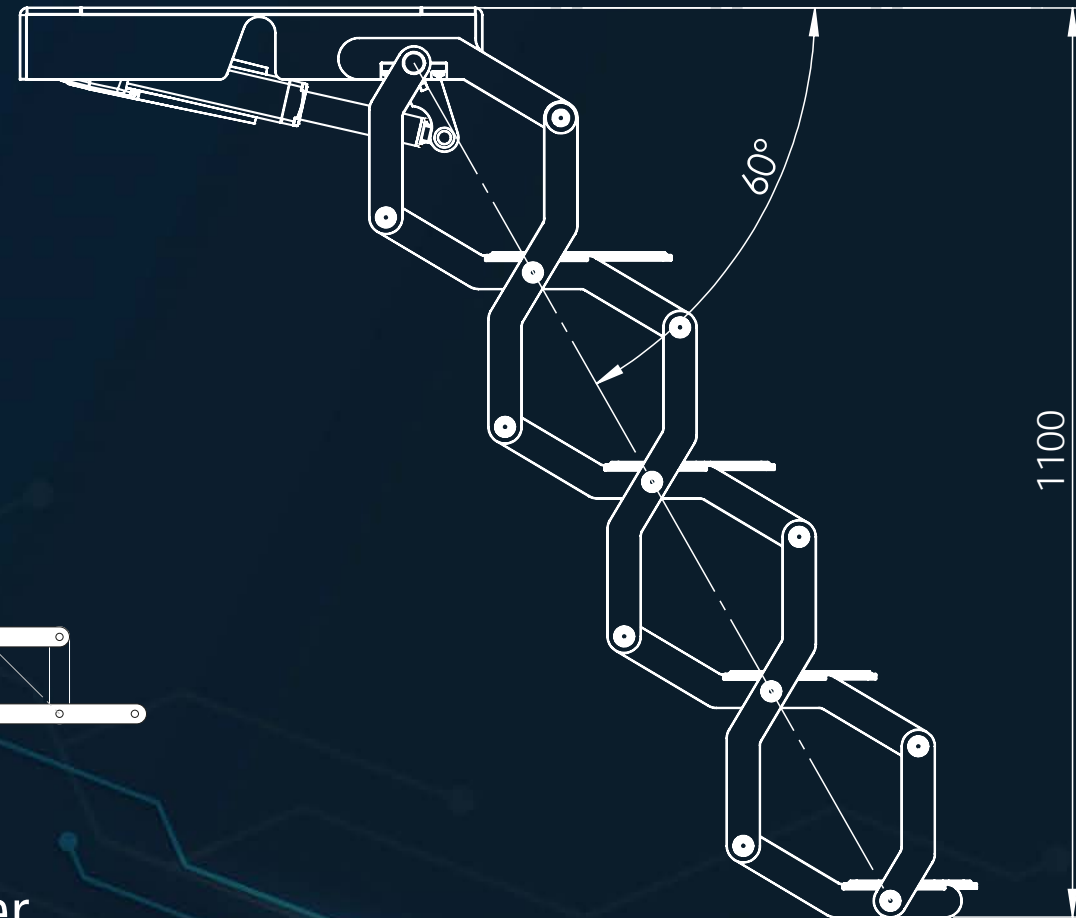
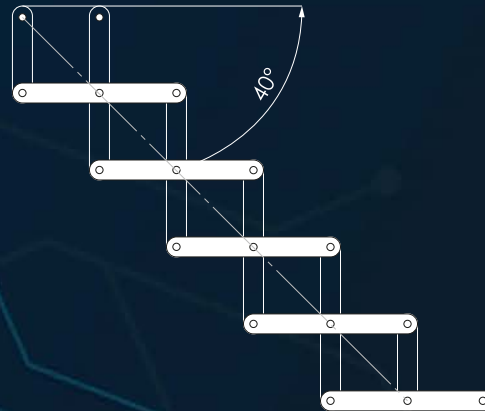

Allowing it to go deeper in order to obtain a comfortable access to enter and exit the water.

To be installed under the stern platform, the first step is design to protrude beyond the structure of the stern platform allowing a backward installation.

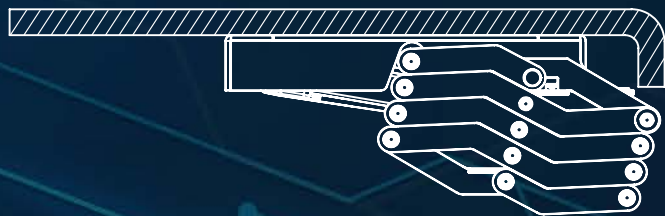

This installation was designed based on the study of anthropometry to ensure the right comfort and stability.

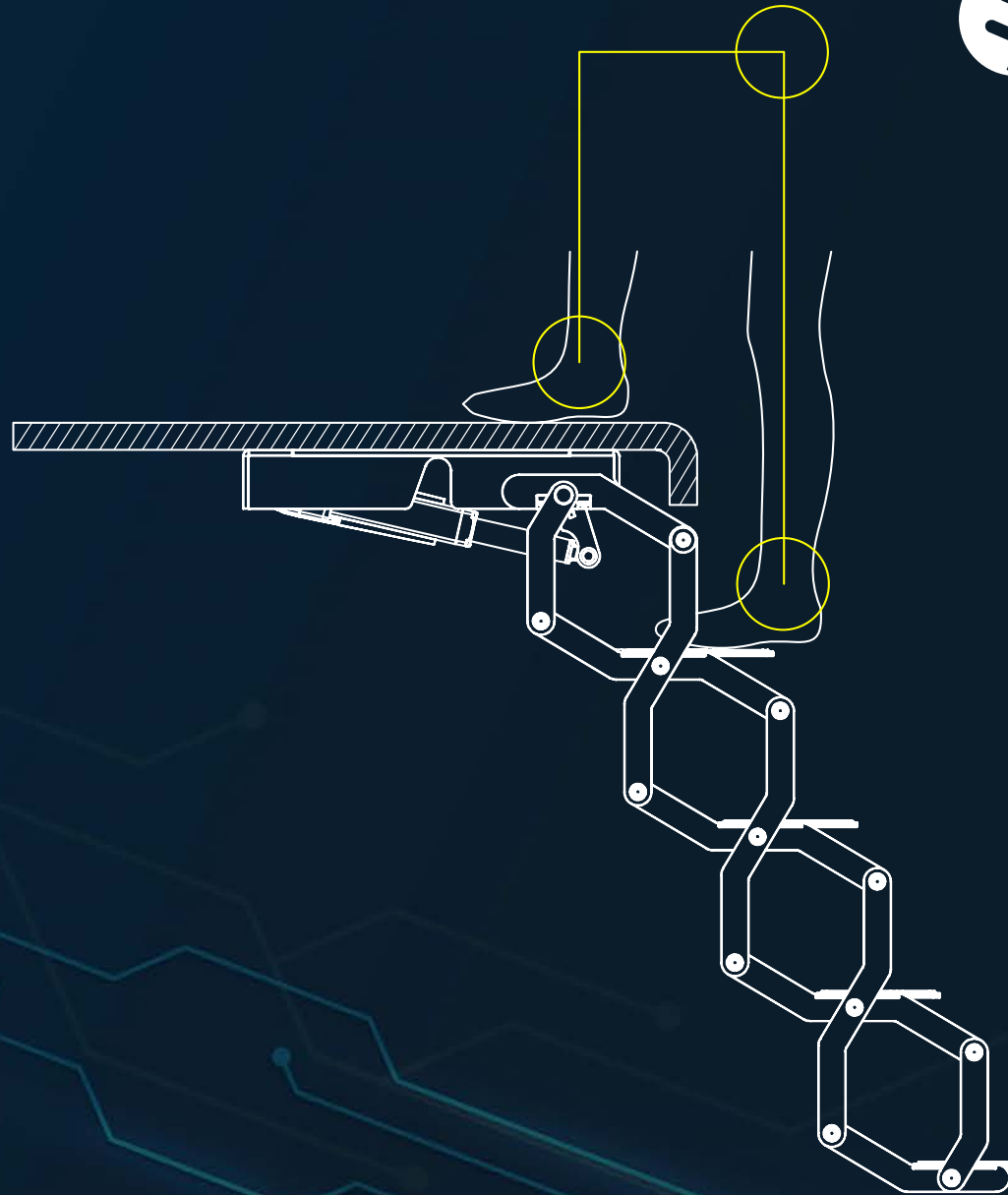



E-step uses an electric linear actuator with a maximum load of 16,000 N, powered by 12 or 24 Volts and an IP69K\* degree of protection to ensure absolute impermeability.

A small two conductor wire is the only transom penetration, no hydraulic lines are required, easy to install.

Speed vs. Load

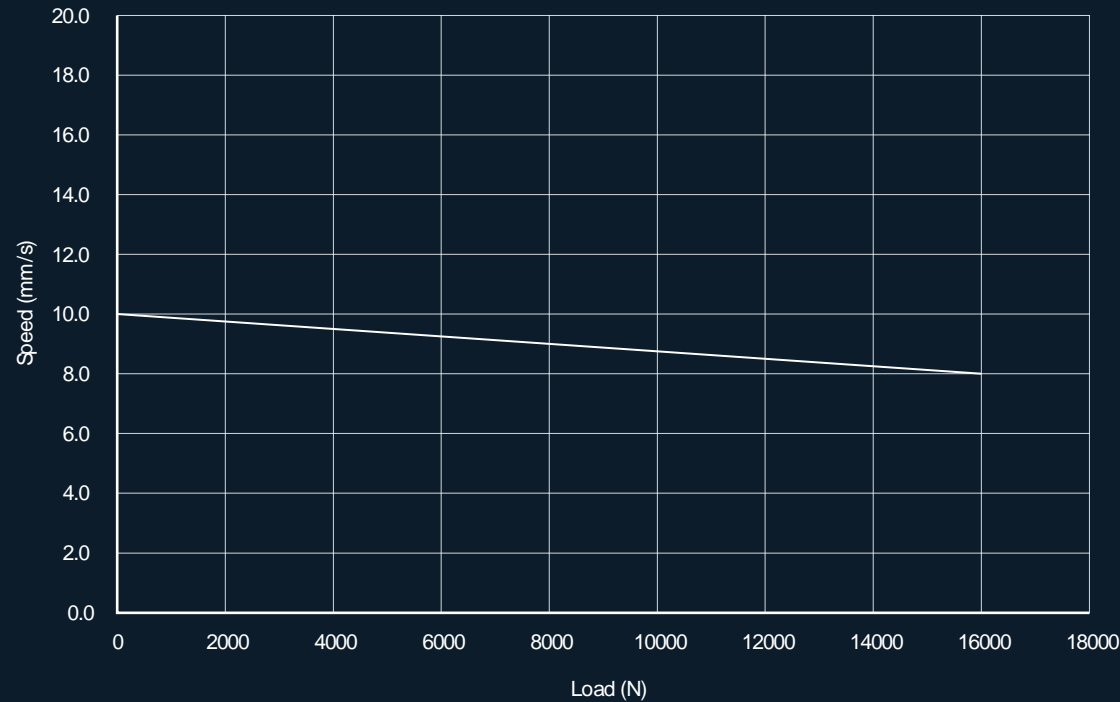

Current vs. Load

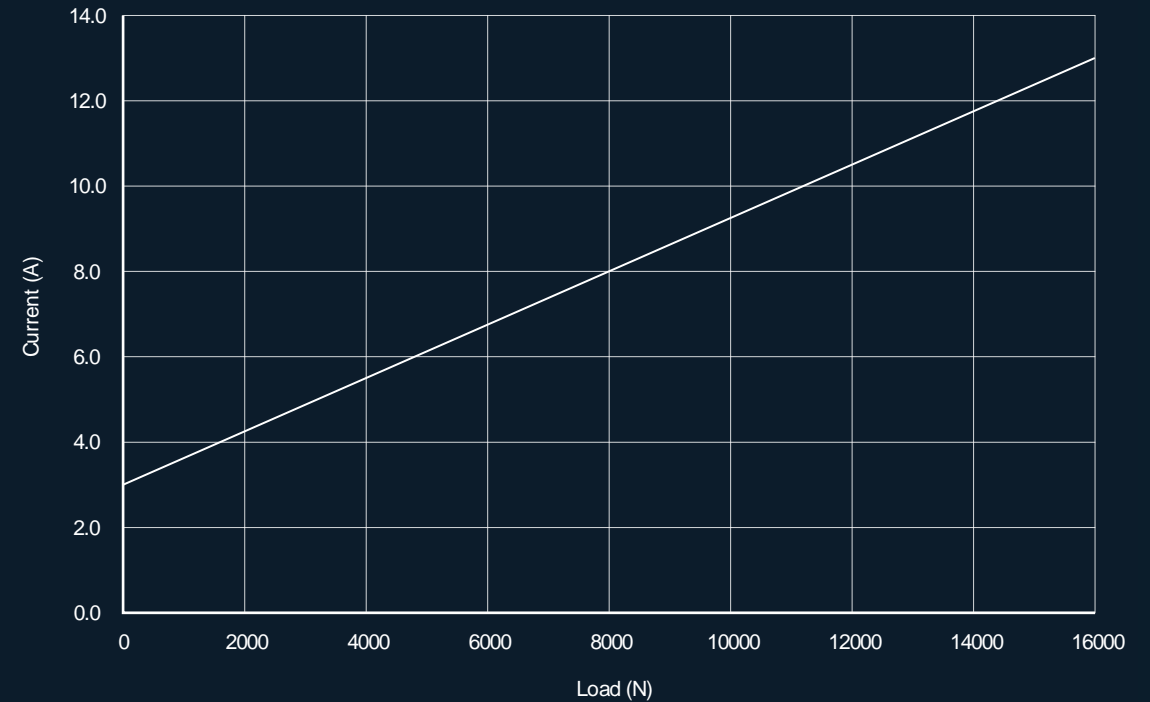

\*IP69K - Maximum protection of the load cell against the penetration of high-pressure water or steam.

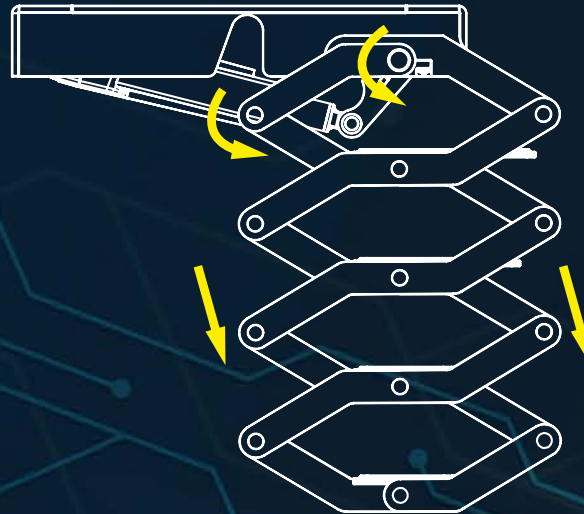
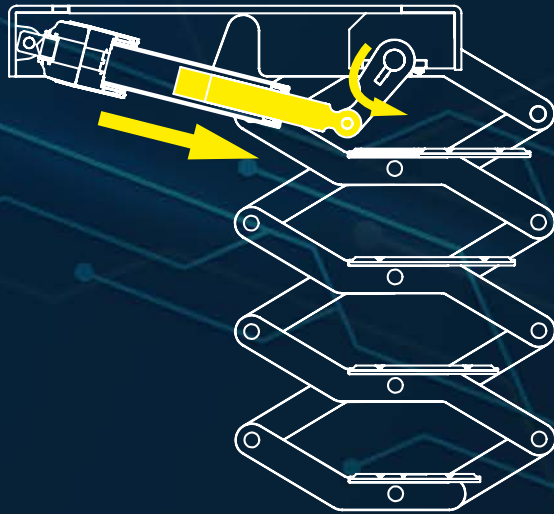
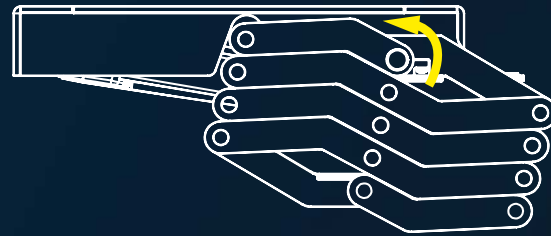
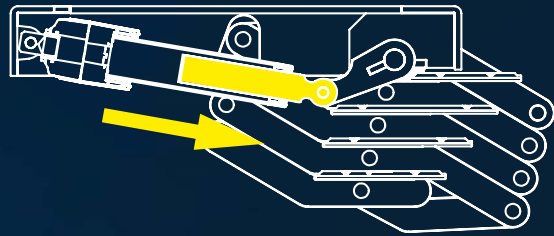

The E-Step system as an all-electric system is extremely low-noise and is operated with a simple switch, or a control unit with remote control that can be installed on request.



## **MATERIALS AND FINISHES**

E-Step's structure is made of lightweight aluminum alloy, with a powder-coated finish, to ensure the correct strength and lowest possible weight.

The steps are covered with a non-slip Eva layer to ensure comfort and safety.

## CUSTOMIZATION

The paintwork can be black or white.

Eva steps can be made in any color combination to match the boat's deck.

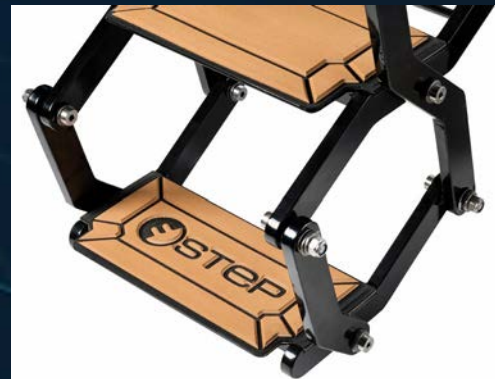

## NOT MORE A LADDER BUT A TRUE STAIRWAY

E-Step fills a gap in the nautical market.



Nowadays motor yacht from 30' to 60' have only two choice: install an economical classic manual telescopic ladder or a very expensive automatic platform.

Finally with E-Steps they will have the best choice at the best price.

### PRICE

1002-003ESTEP: 4.599€

1002-004ESTEP: 5.189€





Thank you.