



Saildrive SD15

The SD15 Saildrive by ZF is designed for use on sailing monohull yachts and catamarans up to 65 feet, enabling the owners of larger sailboats to experience the benefits of YANMAR’s proven range of saildrive solutions. Providing an exclusive combination of common rail and saildrive efficiency for vessels with higher power engines, YANMAR offers the SD15 Saildrive propulsion system with the 4JH80 and 4JH110 engine models. YANMAR’s electronically-controlled common rail engines pair seamlessly with the electric-controlled SD15 saildrive, ensuring clean installation and smooth operation. The SD15’s hydraulic shifting, combined with a recommended folding propeller, reduces noise and vibration, contributing to overall comfort onboard.



FEATURES

- Excellent hydrodynamic efficiency to improve performance and fuel consumption
- Compact installation for more efficient use of space onboard and improved serviceability
- Smooth running and reliable due to hydraulically actuated multi-disc clutches
- Electric shift control seamlessly connects with YANMAR engines
- Integrated output shaft brake
- Durable treatments to maximize corrosion resistance
- YANMAR custom engine mounts, brackets and breathing pipe extension
- YANMAR custom engine bed as option
- Available in standard length (SD15-S) and extended length (SD15-L)
- Matches with Flexofold foldable propellers for safe and efficient operation

SPECIFICATIONS

Model	SD15	
Clutch type	Hydraulically actuated multi-disc clutch	
Reduction ratio	(fwd / rev)	2.51 / 2.51
Direction of rotation (viewed from stern)	Clockwise & counter clockwise	
Lubrication system	Oil bath	
Lube oil specifications	ATF (YANMAR parts code: ATF-1L)	
Max. lube oil capacity	L	6
Length of leg (from flange to prop shaft)	mm	491 (S), 573 (L)
Dry weight saildrive	kg (lbs)	90 (198)
Compatible YANMAR engines	4JH80, 4JH110	



DIMENSIONS

Rear view

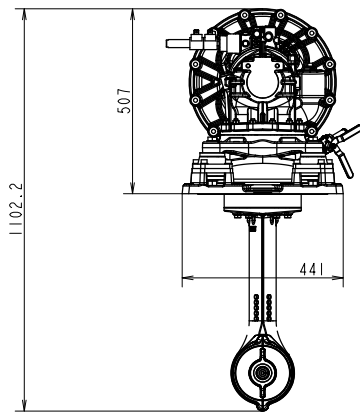

Right side view

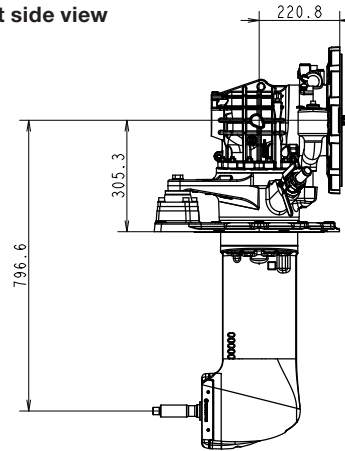

COMPATIBLE ENGINE MODELS

Engine Model		4JH80-SD15	4JH110-SD15
Configuration		In-line, 4-stroke, vertical, water-cooled diesel engine	
Max. output at crankshaft*	kW (mhp) / rpm	58.8 (80) / 3200	80.9 (110) / 3200
Displacement	L (cu.in)	2.000 (122)	
Aspiration		Turbocharged & intercooled	
Dimensions L x W x H	mm	1194 x 684 x 1361	
Emission compliance		USA EPA Tier 3, EPA-C, EU RCD 2, BSO II	
Flywheel housing size		SAE #4	
Dry weight - engine & drive	kg (lbs)	319 (703)	
Dry weight engine without drive	kg (lbs)	229 (505)	

NOTE:

Fuel condition: Density at 15°C = 0.84 g/cm3; 1 kW = 1.3596 mhp = 1.3410 HP. Technical data is according to (ISO 8665)

* Fuel temperature 40°C at the inlet of the fuel injection pump [ISO 8665: 2006]

4JH80 / 4JH110 X SD15-S

Rear view

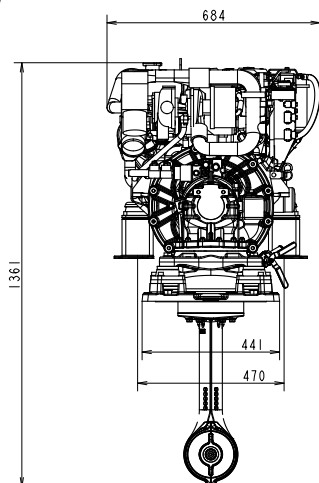

Right side view

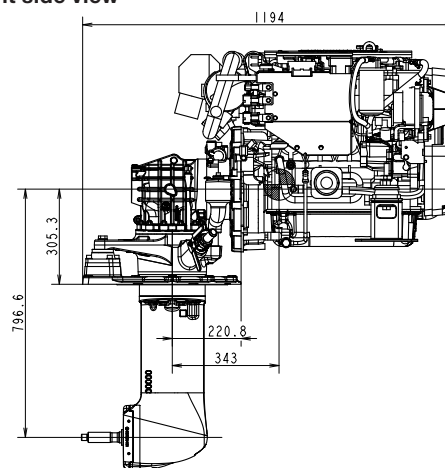

NOTE: All data subject to change without notice. Text and illustrations are not binding.