

The SmartBoat[®] Solution

Crush NMEA 2000[®] Complexity



One SmartBoat Module can perform the work of many different devices, integrating analog sensors, digital sensors, and a wide range of protocols to create the most capable NMEA 2000 network imaginable.

It's that Simple.



The SmartBoat® Solution

Unique. Powerful. Universal. Expandable.

SmartBoat provides a simple and cost-effective way to connect and manage a variety of analog and digital sensors and devices to the NMEA 2000® network – regardless of their protocols. This results in the creation of an intelligent and capable NMEA 2000 network where all data is readily accessible on your MFD.

Monitor Vital Parameters:

- Battery voltage
- Bilge pumps
- Diesel fuel flow
- Engine J1939/J1708/J1587
- NMEA 0183
- Fuel consumption
- Temperatures
- Tank levels
- Weather conditions
- Voltage
- and much more*

Digital Switching & Automation:

- Alerting & automation
- Custom alarms & notifications
- Timers & counters
- Fully programmable actions
- Relay control

Diagnostics:

- BUS traffic and PGNs in human readable format
- Vessel data recorder
- PGN value logging
- Searchable network traffic
- NMEA 2000 traffic replay

Network Bridging & Filtering

*NEW - Cloud Services
(email and SMS notifications)*

Basic NMEA 2000® Network for a Mid-size Vessel with SmartBoat

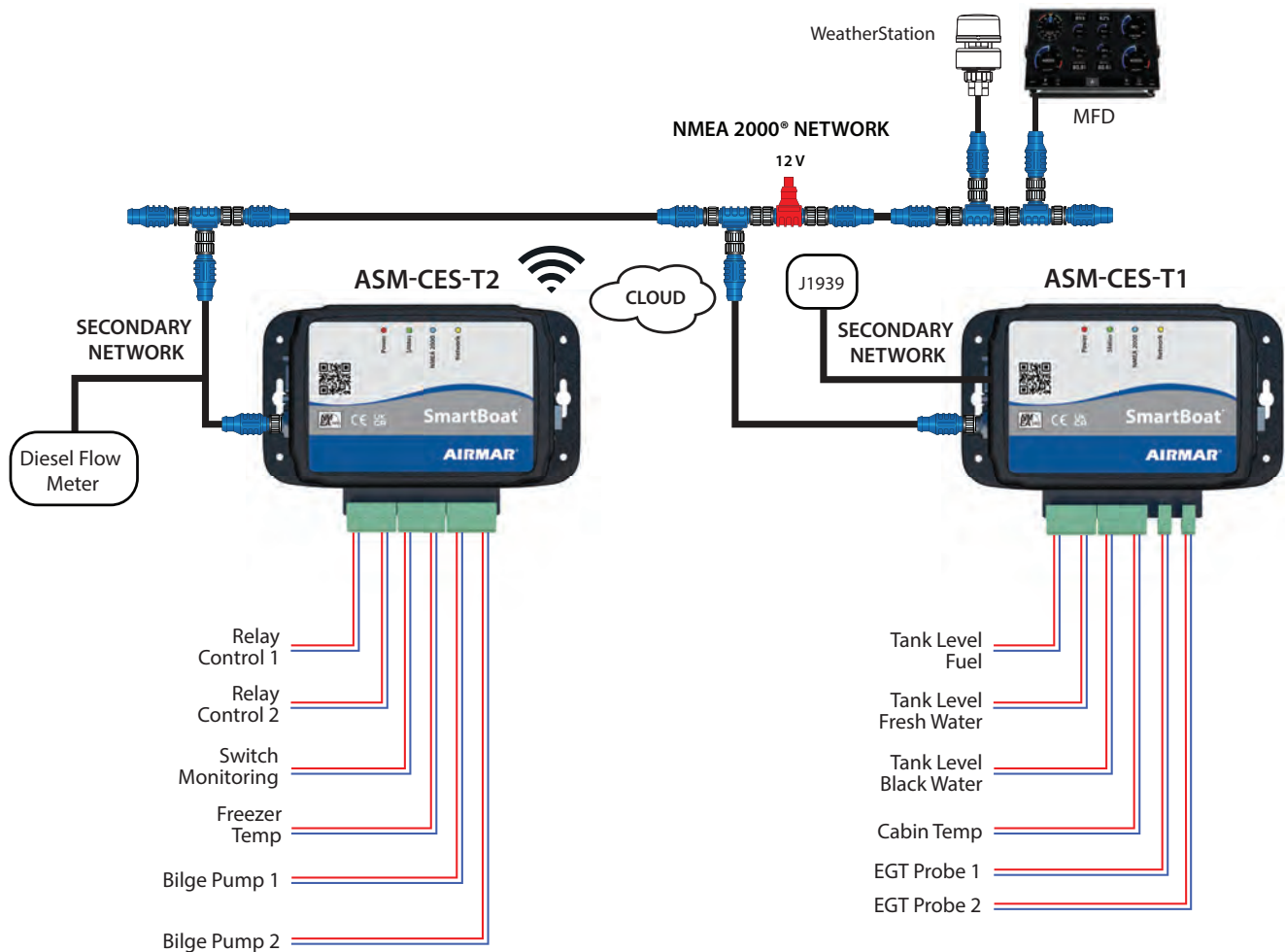

Save up to 68% on a typical retrofit. Each SmartBoat Module is less than \$1,400 (including built-in configuration software and diagnostics). N2K cabling is reduced by 80%.

What Makes SmartBoat Unique?

- The only solution with NMEA OneNet, NMEA 2000, NMEA 0183, J1939, and J1587 support in a single module
- The only solution for fully customizable MFD alerts
- The only solution with Ethernet bridging
- Advanced logging features including the ability to “replay” saved logs
- Savings of up to 68% for a typical retrofit
- 80% reduction of N2K cabling in a typical retrofit

Competitors' Basic NMEA 2000® Network for a Mid-size Vessel

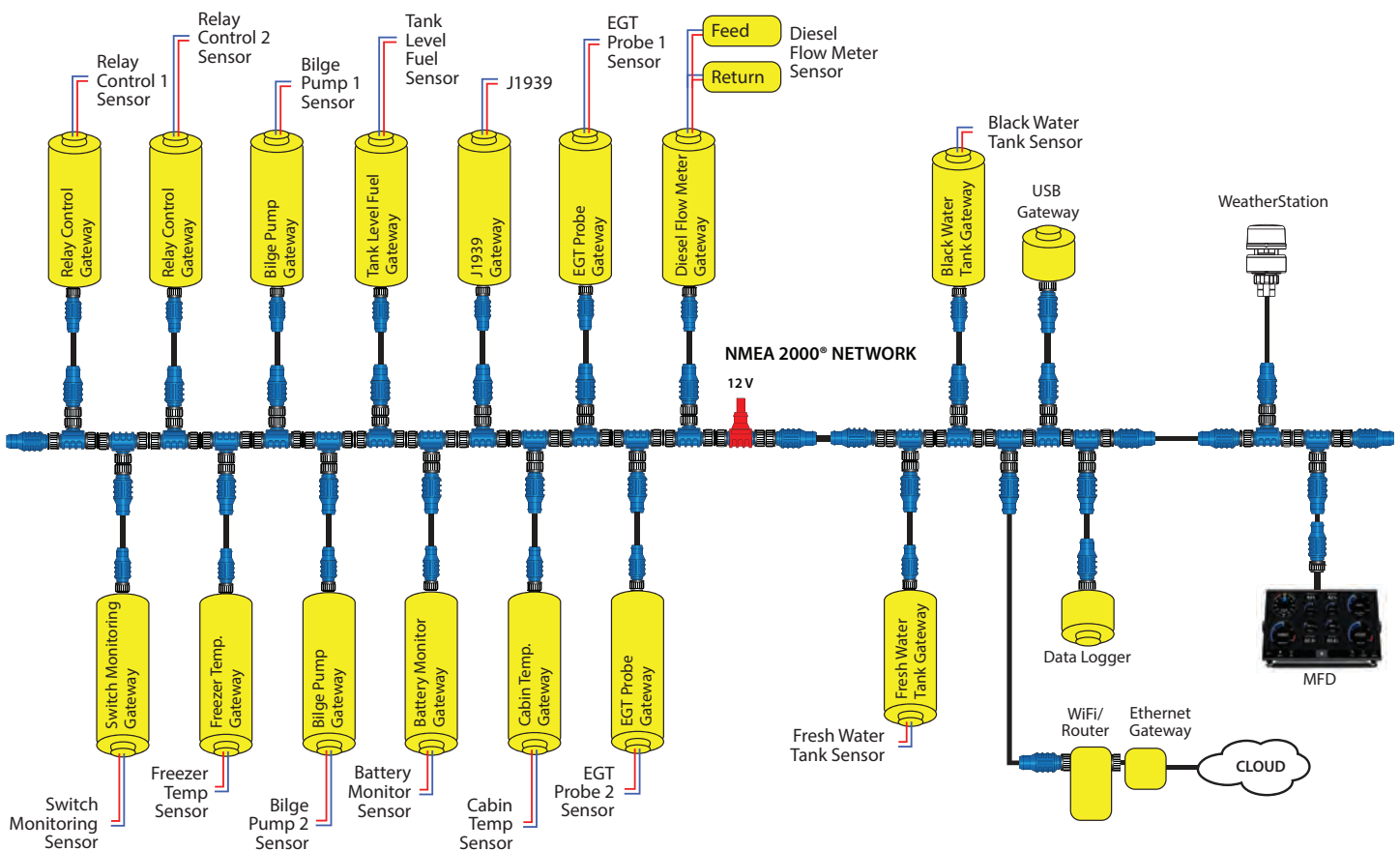

The cost of each gateway is up to \$400. Additional N2K cabling and a separate configuration software are also required resulting in an additional \$2,000 investment. A separate dedicated display may be necessary for sensor configuration.

It Starts with ONE SmartBoat Module

At the heart of the solution is the **Airmar SmartBoat Module (ASM)**, a universal NMEA 2000 device with browser-based SmartFlex™ software that eliminates the need to buy additional hardware, software, or dedicated displays to program the modules or view the data. **All data is readily accessible on your MFD.**

The initial step involves selecting the appropriate ASM for your specific applications. It's important to identify the sensors you intend to connect and the desired features as each module is tailored to support certain types of sensors. For instance, the T1 module is designed to support resistive sensors, thermistors and current loop which are essential for applications like tank monitoring. The T2 module is suitable for resistive sensors, voltage inputs and switches allowing monitoring of motors, pumps, and electrical circuits. If you require more connectivity options, the CES (CAN, Ethernet, Serial) models provide added support for Ethernet, USB ports, and digital engines like J1939/J1708/J1587 and Airmar's diesel fuel flow sensors.

For additional support in choosing exactly the right module(s) for your application, please contact our team at Gemeco Marine Electronics Specialists at 803-693-0777.



A Model for Every Installation!

	ASM-C-T1	ASM-C-T2	NEW FOR 2025! ASM-C-T3	ASM-CES	ASM-CES-T1	ASM-CES-T2	NEW FOR 2025! ASM-CES-T3
Programmable Sensor Inputs	Up to 8 Sensor Inputs per ASM	Up to 4 Sensor Inputs per ASM	Up to 8 Sensor Inputs per ASM		Up to 8 Sensor Inputs per ASM	Up to 4 Sensor Inputs per ASM	Up to 8 Sensor Inputs per ASM
Thermistor (NTC)	✓	✓	✓		✓	✓	✓
Current Loop	4 wire interface		Up to 4		✓		Up to 4
	2 and 3 wire interface	Up to 4	Up to 4		Up to 4		Up to 4
Resistive Senders (US, European, or custom up to 300 OHMS)	✓	✓			✓	✓	
Resistive Senders (US, European, or custom up to 1000 OHMS)			✓				✓
Binary Switch	✓	✓	✓		✓	✓	✓
Voltage (0-75VDC)		✓	Up to 4			✓	Up to 4
Fixed Sensor Inputs							
Thermocouples (J,T,K,E types)*	2				2		
Relays (10A Resistive, 5A Inductive)		4	1			4	1
Run Detector (9-240VDC/VAC rms)		4				4	
Pulse			4				4
External Connections							
Primary NMEA 2000	✓	✓	✓	✓	✓	✓	✓
WiFi	✓	✓	✓	✓	✓	✓	✓
USB 2.0				2	2	2	2
Ethernet (RJ-45)				1	1	1	1
Secondary Network DB9 Male includes: SmartFlex™ Diesel Flow Meter, J1939/J1708/J1587 or NMEA 2000 (secondary) NMEA 0183 (RS-422, RS-485, RS232)				1	1	1	1
Signal K compatibility	✓	✓	✓	✓	✓	✓	✓
OneNet®				✓	✓	✓	✓

* Dry Exhaust

Diesel Flow Meter Specifications

NEW Airmar SmartFlex™ Diesel Flow Meters

Airmar's innovative SmartFlex™ Diesel Flow Meters (DFMs), offer a groundbreaking solution that has redefined the way diesel fuel is monitored and managed in the marine industry. These cutting-edge sensors seamlessly integrate with the award-winning Airmar SmartBoat Modules (ASMs) through a digital interface, offering unmatched precision and efficiency. With models catering to various flow rate requirements (.2 to 1100 gallons/hour), our DFMs are setting new standards in accuracy, ease of installation, cost-effectiveness, and fuel system longevity.

Part Numbers and Specifications

Part Number	Variations	Chambers	Working Range	Weight	Mounting L x W	Thread Type
DFM-50-SA	-L	Single	1 – 50 LPH ±1% (.2 – 2 GPH ±1%)	0.96 kg (2.11 lbs)	90 x 70 mm (3.54" X 2.75")	M14 x 1.5
DFM-100-SA	-L	Single	2 – 100 LPH ±1% (.5 – 26 GPH ±1%)	0.96 kg (2.11 lbs)	90 x 70 mm (3.54" X 2.75")	M14 x 1.5
DFM-250-SA	-L	Single	5 – 250 LPH ±1% (1 – 66 GPH ±1%)	1.30 kg (2.86 lbs)	90 x 70 mm (3.54" X 2.75")	M14 x 1.5
DFM-500-SA		Single	10 – 500 LPH ±1% (2 – 132 GPH ±1%)	1.29 kg (2.84 lbs)	90 x 70 mm (3.54" X 2.75")	M16 x 1.5
DFM-1000-SA-L	F, -SB	Single	20 – 1000 LPH ±1% (5 – 264 GPH ±1%)	2.90 kg (6.39 lbs)	42 x 32 mm (1.65" X 1.25")	1/2" BSP
DFM-2000-SA-L	F, -SB	Single	40 – 2000 LPH ±1% (10 – 528 GPH ±1%)	3.12 kg (6.87 lbs)	42 x 16 mm (1.65" X .62")	3/4" BSP
DFM-4000-SA-L	F, -SB	Single	80 – 4000 LPH ±1% (21 – 1056 GPH ±1%)	5.64 kg (12.43 lbs)	52 x 20 mm (2.04" X .78")	1" BSP
DFM-100-DA		Dual	2 – 100 LPH ±1..3% (.5 – 26 GPH ±1%)	1.50 kg (3.30 lbs)	135.8 x 45 mm (5.34" X 1.77")	M14 x 1.5
DFM-300-DA		Dual	50 – 300 LPH ±1..3% (13 – 79 GPH ±1%)	2.16 kg (4.76 lbs)	152.8 x 45 mm (6.01" X 1.77")	M14 x 1.5
DFM-600-DA		Dual	100 – 600 LPH ±1..3% (26 – 158 GPH ±1%)	2.07 kg (4.56 lbs)	155.8 x 45 mm (6.13" X 1.77")	M16 x 1.5

Variations available by special order: F (Flange mount) / -L (LCD display) / -SB (Brass housing)

Specifications in this table are for versions with threaded connection versions with alloy housings

Accuracy can vary according to ratio of feed chamber and reverse chamber flow rate

Common Specifications

Parameter	Value
Maximum Pressure	25 bar
Kinematic Viscosity	1.5 – 6.0 mm ² /s (cSt) (.059" – .23" ² /s (cSt))
Threaded connections	M14 x 1.5 unless noted
Maximum size of inclusions	0.08 mm (.003")
Max Pressure drop at max flow	0.2 bar
Supply voltage range	10 – 16 VDC
Operating ambient temperature	-40 – 85 °C (-40 – 185 °F)
Water ingress protection	IP54

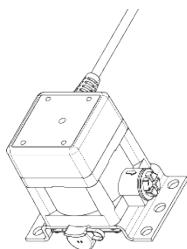

Single-Chamber DFM

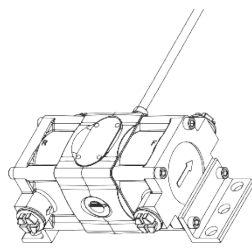

Dual-Chamber DFM

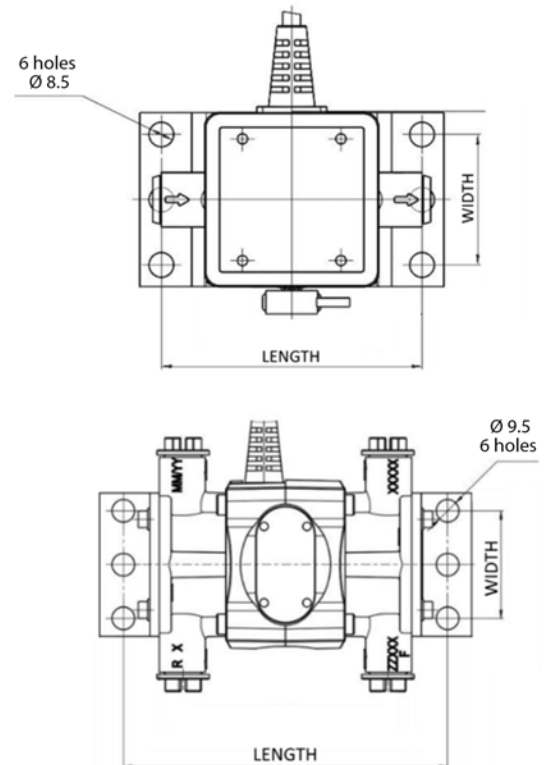

www.airmar.com

© AIRMAR Technology Corporation

Patent Pending



SmartBoat_Print_Catalog_rG 09/05/24