

PRO's CHOICE!

**BS.PRO**

Built Strong, Powered Ready, Outperforming

# Electric Thruster System / Hydraulic Thruster Propeller



## Electric Thruster System

- DC electric motor, bevel gear, aluminum propeller
- Prevent motor overheating
- Registered as fishing equipment by the Korea National Federation of Fisheries Cooperatives

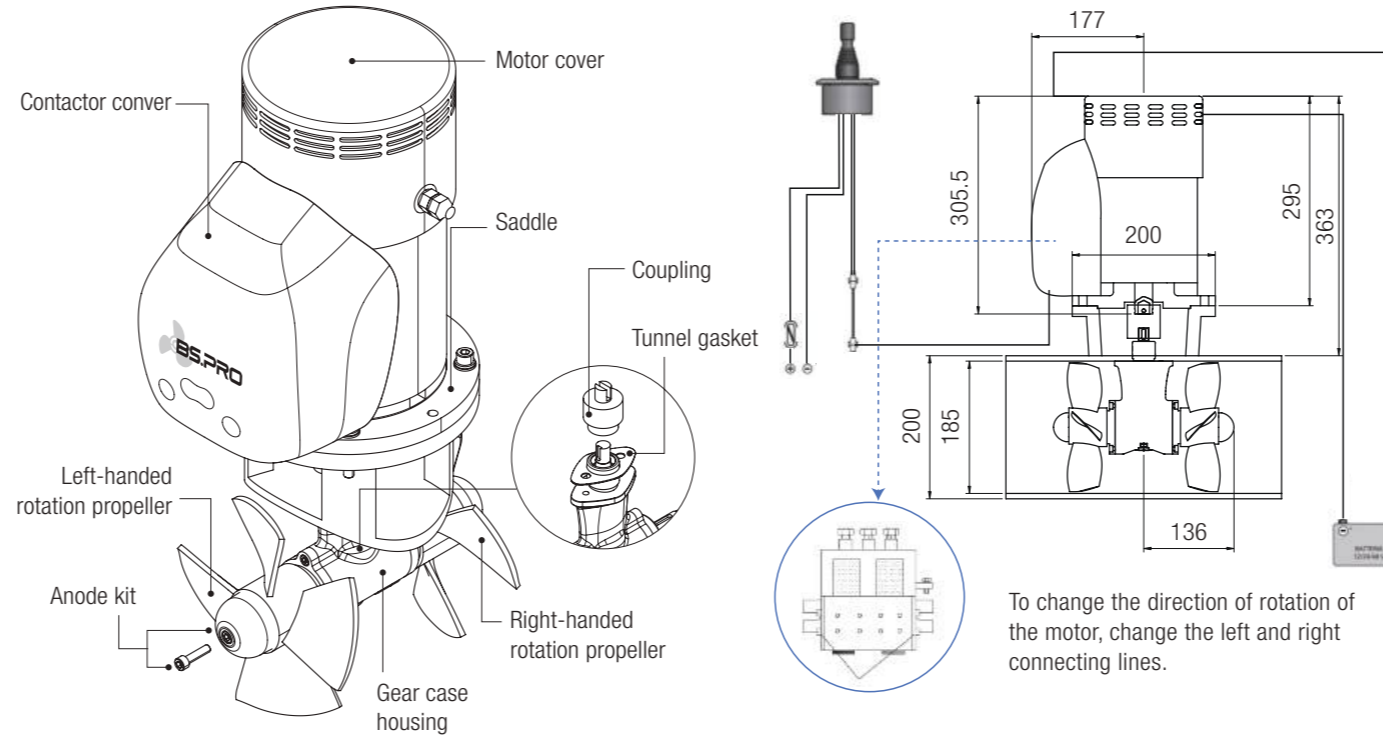

### Model : BET-185 |

Power Supply	Thrust	Boat length	Tunnel(I.D.)	Type	Power	Battery(Min)	Weight
DC 12V,24V	62 kgf	27~37 ft	140mm	single	2.4kw 3hp	12V130F51 24V80D26	15Kg
DC 12V,24V	73 kgf	29~39 ft	185mm	single	3.1kw 4hp	12V130F51 24V80D26	16Kg
DC 12V,24V	95 kgf	35~48 ft	185mm	twin	4.4kw 6hp	12V145F51 24V105E41	24Kg
DC 12V,24V	115 kgf	39~55 ft	185mm	twin	6.3kw 8hp	12V210H52 24V130F51	31Kg

### Part List |



## Examples of Electric Thruster Installations |



\* Control system that can protect the motor and gear by setting the operating time of the motor.

## THRUSTER PROPELLERS

THRUSTER Series	ETH-165	ETH-180	BTY-250	BTY-300	BTY-340	BTY-350	BTY-390	BTY-450	BTS-380
Diameter (mm)	165	180	250	300	340	350	390	450	380
Blades	4	4	4	4	4	4	4	4	4
Propulsion System	Twin	Twin	Single	Single	Single	Single	Single	Single	Twin
Shaft Diameter (mm)	14	14	22.2	22.2	35.5	35.5	35.5	32	23~30

## Examples of Hydraulic Thruster Propeller Installations |

