

# Plastic rainwater tanks – in door



Basis tank 2,000 liters



- ▶ Protection against algae formation due to lightproof black polyethylene
- ▶ integrated calmed inlet DN 100 and overflow siphon DN 100
- ▶ modular system, expandable as desired
- ▶ large opening for tank cleaning or installation of a submersible pump

Our above-ground PE cellar tanks are quality-assured by the RAL quality seal "Rainwater systems PE storage tanks" and comply with the KTW recommendation.

Article no.	Description	Length mm	Width mm	Height mm	Height approx. mm	Height over-flow mm	Weight kg
962003	Basic tank RWN-O 1100 B	1,400	820	1,400	1,470	1,130	55
971301	Extension tank 1100 DF	1,400	720	1,400	–	–	53
962005	Basic tank RWN-O 1500 B	1,560	820	1,640	1,710	1,390	73
971303	Extension tank 1500 DF	1,560	720	1,640	–	–	71
962007	Basic tank RWN-O 2000 B	2,070	820	1,690	1,760	1,375	113
971305	Extension tank 2000 DF	2,070	720	1,690	–	–	111
962012	Basic tank RWN-O 2500 B	1,870	1,095	1,650	1,720	1,330	118
971306	Extension tank 2500 DF	1,870	995	1,650	–	–	116
962061	Basic tank RWN-O 3000 B	2,230	1,095	1,650	1,720	1,330	169
971307	Extension tank 3000 DF	2,230	995	1,650	–	–	166
962063	Basic tank RWN-O 4000 B	2,430	1,095	1,950	2,020	1,500	239
971309	Extension tank 4000 DF	2,430	995	1,950	–	–	236



Types 1100 and 1500 with a upper connection 2", 2500 to 4000 with 3 connections 2"

Basement tank with calmed inlet and overflow sip

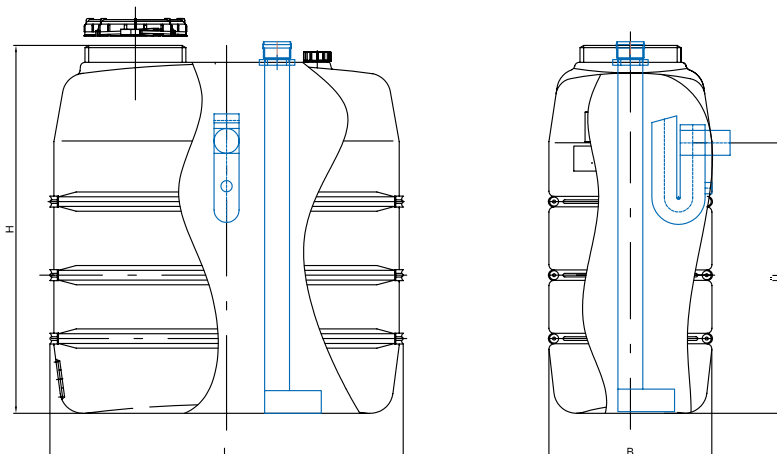



Article no.	Description
<b>Inline filter for underground installation and in house installation for up to 450 m<sup>2</sup> roof area</b>	
810745	Inline filter 450 for underground installation
811184	Inline filters for in-house installation
<b>Accessories</b>	
810746	Revision pipe 0.75 m



Article no.	Description
<b>Drinking water feeding for PE storage tanks</b>	
810400	Magnet valve 1/2" with float switch 230 V and 10 m cable
810397	Magnet valve 1" with float switch 230 V and 10 m cable
810398	Magnet valve 1 1/2" with float switch 230 V and 10 m cable
810399	Magnet valve 2" with float switch 230 V and 10 m cable

Servo-controlled magnet valves for drinking water feeding with direct connection to PE storage tanks, AQF tanks or rainwater storage tanks. The lateral rectangular emergency overflow required for compliance with DIN EN 1717 can be attached to the tank at the factory upon request.

## Accessories lower circulation line for unlimited storage volume



Article no.	Description
<b>Accessories Battery installation with individual shut-off for storage tank PE-DF</b>	
971565	Basic package DF connecting pipe DN 50 for 2 PE Dom tanks with two 1 1/2" taps
971570	Extension DF for connecting further PE Dom tanks with a 1 1/2" tap

Lower connection line with connection flange and stopcock 1 1/2" for PE storage tanks for on-site connection plastic pipe DN 50 (outer diameter 63 mm).



Article no.	Description
<b>Accessories Battery installation with individual shut-off for storage tank PE-DF</b>	
971555	Basic package DF connecting pipe DN 50 for 2 PE-Dom tanks
971560	Extension DF for connecting additional PE-Dom tanks
71645	Stopcock 2" for shutting off the connecting line DN 50
62276	Venting hood 2"

71645 Stopcock with 2" IT for shutting off the connecting line.