

SEABOB Safety Case

A security system for a secure system.



EN

CAYAGO
CAYAGO AG
Flachter Str. 32
D-70499 Stuttgart
GERMANY

Sales:
CAYAGO AG
Benzstr. 10
D-32108 Bad Salzuflen
GERMANY

Tel.: +49 5222 8509-0
info@seabob.com
www.seabob.com

As of 01/2024
Errors excepted.
© 2024 CAYAGO AG
All rights reserved.

Imprint. The SEABOB models and accessories depicted in this catalogue are the latest models. Technical specifications and design are subject to change. The colour samples in this catalogue may differ from the actual colours.



The SEABOB Safety Case. The highest level of safety.

Insurance policies in the yachting industry impose top safety requirements upon the stowage of lithium-ion batteries on board. In June 2023, the United Kingdom Maritime & Coastguard Agency defined the principles for the safe charging and stowage of lithium-ion batteries on yachts in Marine Guidance Note MGN 681 (M).

The SEABOB Safety Case meets these safe stowage requirements. It is equipped with an automatic extinguishing system and top safety thanks to modern connectivity with your smartphone or tablet.

All kinds of electrically powered water sports products as well as lithium-ion batteries are ideally protected in the SEABOB Safety Case in the event of a fire. The safety system disposes of a catalyst that filters out and neutralizes harmful gases. The temperature of escaping emissions is greatly reduced during this process.

Stowage options on board.

Versatile and variable.

SEABOB Safety Case Drawer

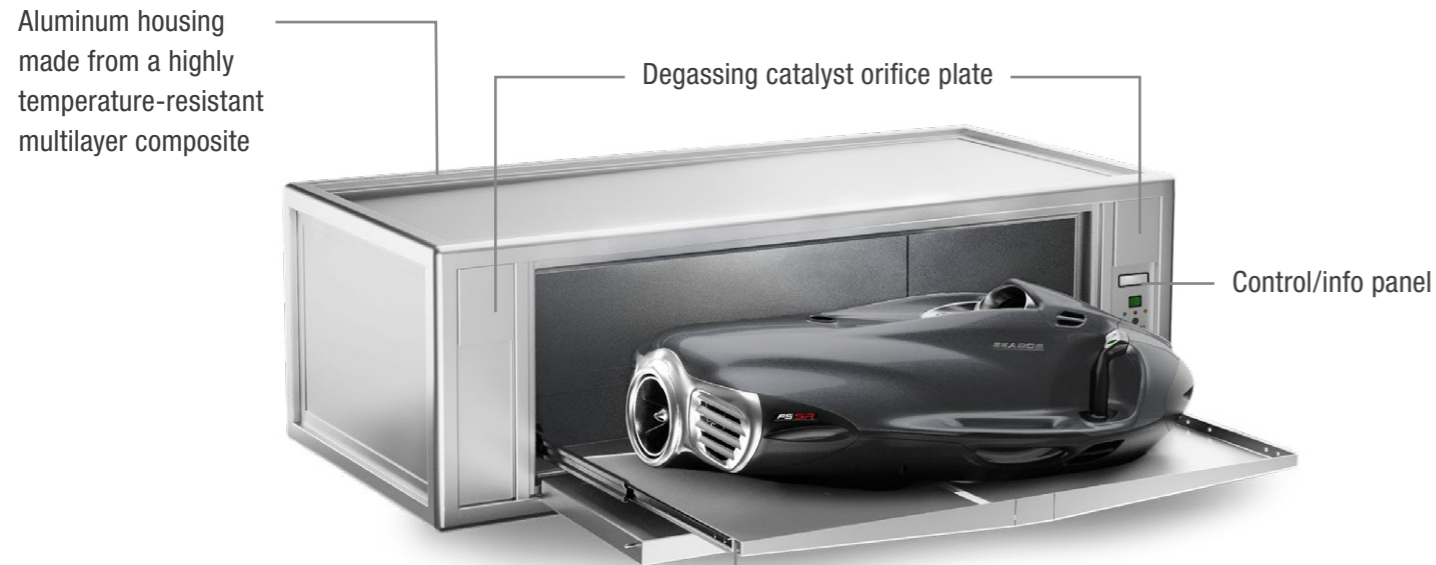

Aluminum housing made from a highly temperature-resistant multilayer composite

Degassing catalyst orifice plate

Control/info panel

Fully telescopic drawer.

The SEABOB is fixed to a stainless steel rail-mounted drawer.

Space-saving profile.

The Safety Case Drawer product version features an integrated profile system. This allows the product to be stacked to provide space-saving stowage.

SEABOB Safety Case Rotation



Degassing catalyst orifice plate

Control/info panel

Aluminum housing made from a highly temperature-resistant multilayer composite

Hanging system

Connection port

The rotating door. For easy handling.

The Safety Case Rotation has a rotating door. This allows the Safety Case to be opened quickly and the SEABOB to be removed as easily as possible.

Charging option in Safety Case.

The SEABOB can be charged in the Safety Case with a charging device whenever needed while remaining in safe stowage.

Perfect ergonomics.

Both product variants have a sophisticated operating concept so that the SEABOB can be easily removed from its case and stowed away again safely.

The technical specifications.

SEABOB Safety Case Rotation

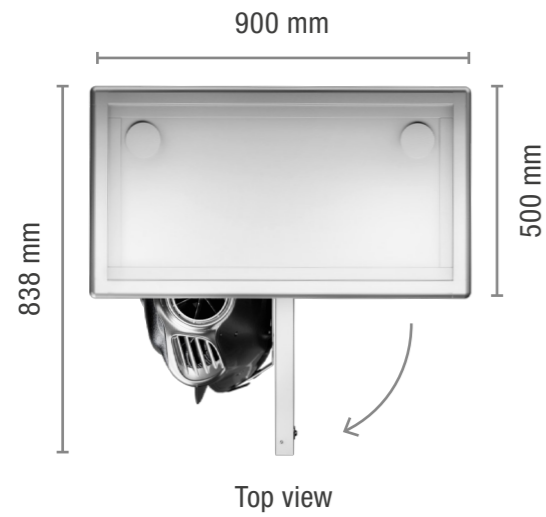

SEABOB Safety Case Drawer

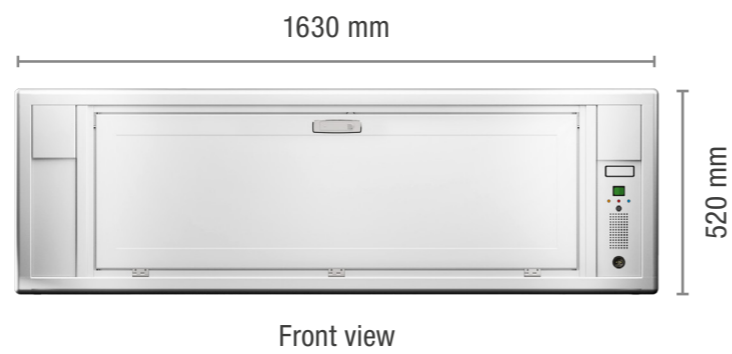
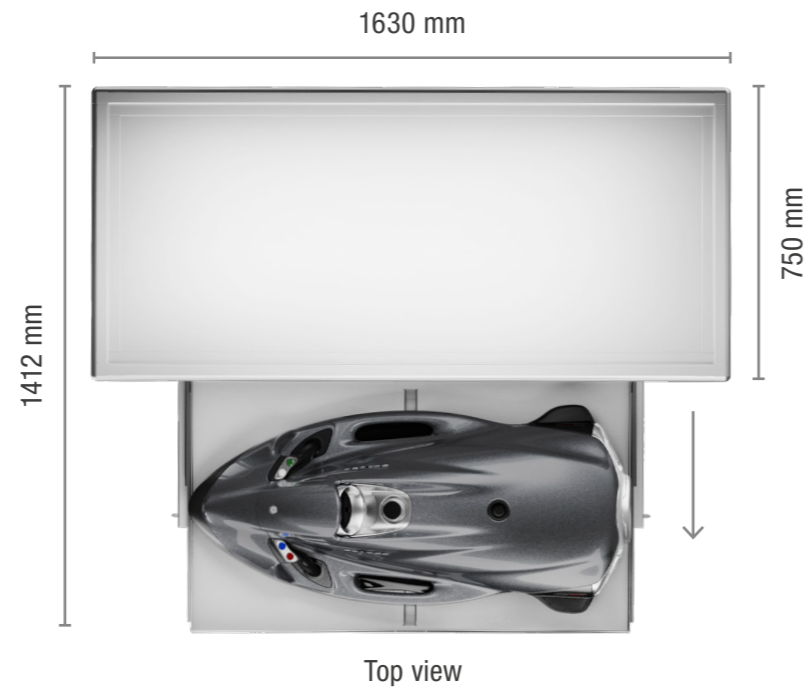

Designation	Safety Case Rotation	Safety Case Drawer
Housing	Aluminum housing made from a highly temperature-resistant multilayer composite	
Dimensions when closed (WxHxD)	900 x 1630 x 500 mm	1630 x 520 x 750 mm
Dimensions when open (WxHxD)	900 x 1630 x 838 mm	1630 x 520 x 1412 mm
Weight	78 kg / 172 lbs	
Compatibility	Compatible with all SEABOB vehicles from Model Range F5	
Color	Silver E6/EV1	
Guideline	UK Maritime & Coastguard Agency MGN 681 (M)	
Waterproofing	Splash-proof	

We reserve the right to make technical changes and apply tolerances.

