

HydroGuard™ Series

Shock arresting



Features

- High grade butyl diaphragm
- Adjustable pre-charged air pressure
- Dual layer polyurethane paint finish
- Leak free O-ring sealed air valve
- Comprehensive testing
- Maintenance-free



Certifications may vary by model. Check with your GWS sales representative for more detailed information.

HydroGuard™ shock arrestors are specially built with the latest diaphragm technology designed to reduce and eliminate hydraulic shock. The internal diaphragm divides the arrestor into separate air and water chambers. The sealed air chamber acts as a cushion that compresses when the water pressure suddenly increases or surges due to hydraulic shock.

HydroGuard shock arrestors are best used at the point of shock and should be installed as close to the valve or piping where the shock originates. They are ideal for washing machine and dish washer installations, sinks and toilets, reverse osmosis systems and any other plumbing application where quick closing valves or fast-acting solenoid valves are installed.

HydroGuard shock arrestors are certified and approved for potable water systems and are drinking water safe. Each HydroGuard shock arrestor is quality tested at several stages along the production line to ensure the structural integrity and safety of every arrestor.

HydroGuard shock arrestors represent the best value for the investment and are the best quality shock arrestors available today.

What is Water Hammer?

Hydraulic shock, also known as Water Hammer, is the sudden pressure surge or shock wave that is created when water is stopped or forced to change direction suddenly. This usually occurs due to fast-acting solenoid valves or other quick closing valves as well as pipe bends, elbows, and other plumbing transitions. The shock wave causes a rapid spike in pressure that may result in burst pipes, excess stress on joints and fittings, leaky taps and faucets as well as damage to appliances. It can also cause pipes to vibrate and rattle creating banging or knocking noises inside walls.

Models

Model Number		Connection	Nominal Volume		Dimensions (mm)		Pieces per box	Gross Weight [kg]
BSP	NPT		Liters	Gallons	A	B		
Carbon Steel								
HGBSC-0.3LX-C0.25	-	¼" BSPP	0.3	0.08	103	97	40	16.4
HGBSC-0.3LX-C0.50	-	½" BSPP	0.3	0.08	104	97	40	16.0
HGBSC-0.5LX-C0.25	-	¼" BSPP	0.5	0.13	134	113	24	15.4
HGBSC-0.5LX-C0.50	-	½" BSPP	0.5	0.13	135	113	24	15.4
HGBSH-0.6-C0.50	-	½" BSPP	0.6	0.16	159	97	20	11.4
HGPSE-1LX-C0.50	-	½" PF	1.0	0.26	197	120	20	17.6
HGPSR-1LX-C0.50	-	½" PF	1.0	0.26	197	120	20	17.4
HGBPA-2LX	HGNPA-2LX	1" BSP / 1" NPT	2.0	0.5	208	126	12	13.8
HGBPA-3LX	HGNPA-3LX	1" BSP / 1" NPT	3.0	0.8	243	143	6	9.13
HGBPA-4LX	HGNPA-4LX	1" BSP / 1" NPT	4.0	1.1	261	162	1	1.66
Stainless Steel								
-	HGNSA-0.16LX-C0.25	¼" NPT	0.16	0.04	102	85	24	8.2
-	HGNSA-0.16LX-C0.50	½" NPT	0.16	0.04	113	85	24	8.2
HGPSB-1LX-C0.50	-	½" PF	1.0	0.26	144	136	15	11.9

Check with your representative for compatibility between thread types.

Note: Minor dimensional variations may occur.

Specifications

Product Series Name	HydroGuard™
Nominal Volumes	0.16 - 4 L / 0.04 - 1.1 gal
Materials	See individual data sheets
Max. Operating Temperature	90°C / 194°F
Max. Operating Pressure	10 bar 150 psi
Factory Pre-charge	Available with 1 or 4 bar (14.5 or 58 psi)

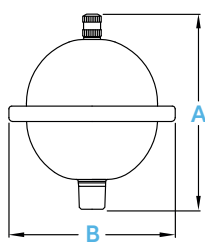
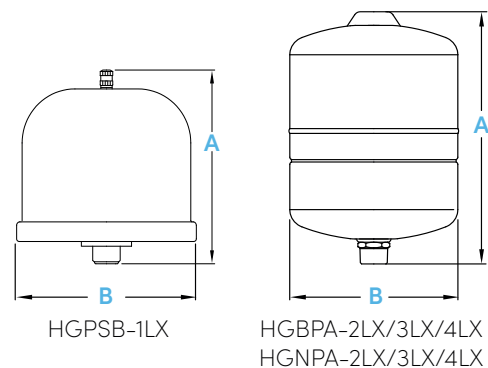

HGNSA-0.16LX

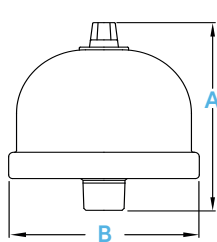

HGBSC-0.3LX

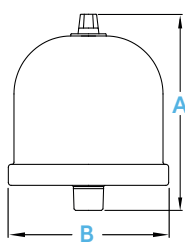

HGBSC-0.5LX

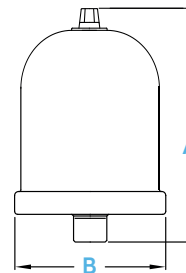

HGBSH-0.6LX

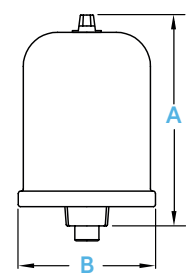

HGPSE-1LX
HGPSR-1LX

SHOCK ARRESTING