

Designed and manufactured in France by :
Kitewinder
1 Allée Jean Rostand
33650 Martillac, France
www.kitewinder.fr



SEAWING

Hydro-generator

User Manual

Version 1.0

February 2025



Table of Contents

1. Introduction	3
2. Content	4
3. Safety Precautions	5
4. Overall principle	6
5. Specifications	7
6. Mechanical setup	8
7. Electrical setup	9
7.1. Configuration 1: In-cabin electrical box option (through bulkhead).....	9
7.2. Configuration 2: Mobile electrical box option (direct connection).....	14
7.3. Connecting the electrical box to the batteries.....	15
8. Installation and configuration of the electrical box	18
8.1. Battery voltage	18
8.2. Bluetooth application settings	19
8.3. Firmware update	21
9. Use of the hydro-generator	22
9.1. Putting the system into water.....	22
9.2. Operation	23
9.3. Adjusting the depth of the hydro-generator.....	24
9.4. Getting the system back.....	24
9.5. Testing the hydro-generator via Bluetooth.....	25
10. Care and maintenance	26
11. Disassembly	27
12. Warranty	30

1. Introduction

Seawing is a towed hydro-generator. It allows you to recharge your boat's batteries while you sail. It is connected to your boat by a flexible cable that provides both mechanical support and electricity transfer.

The hydro-generator consists of a marine aluminum frame to which two counter-rotating propellers, a float, and a hydrofoil are attached, allowing the system to dive. Sacrificial anodes prevent corrosion problems. It weighs approximately 6 kg and its propellers have a diameter of 240 mm.

As soon as the boat speed exceeds 3 knots, the hydro-generator's propellers start and charge the battery. The system is stabilized in the water thanks to the float and the hydrofoil. The hydrofoil, inclined at 12°, maintains the system at an optimal depth throughout the hydro-generator's operating speed range (depth between 0.5m and 1.5m).

The system's output depends on several factors. Generally speaking, the faster the boat, the higher the output, reaching a maximum output of 600 watts. This maximum output is reached at 9 knots. The system can operate on 12-24V or 48 volts, depending on the option chosen. The hydro-generator is equipped with two 240mm diameter propellers as standard. Please contact us if you require propellers of a different diameter.

The connecting cable is made up of 6 extra-flexible silicone cables with a cross-section of 2.5mm². These cables are covered with a Dyneema braid that handles the drag force of the hydro-generator, ensuring that the electrical cables are not mechanically stressed. A stainless steel carabiner allows you to attach the system to an existing attachment point on your boat. We recommend positioning this attachment point at a height of 60 centimeters above the waterline to ensure optimal operation (maximum height 1.3m).

The cable length between the carabiner and the hydro-generator is 3.2m. The length of the electric cable between the carabiner and the electrical connector can be adapted to your needs. This length is 1 meter as standard.

The electrical installation is kept to a minimum. An aluminum electrical box must be installed as close as possible to your batteries (Lithium-Ions, Lithium-Iron-Phosphate, Lead-Acid). You have the choice of using the bulkhead connector supplied with our hydro-generator (configuration 1). If you do not wish to drill into the hull, the electrical box can be placed on the deck of the boat (configuration 2) and connected to the hydro-generator using the same bulkhead connector as configuration 1, but mounted directly on the electrical box. Your battery bank is connected to the output of the electrical box with two doubled 6 mm² cables.

A Bluetooth smartphone application allows you to configure and monitor the hydro-generator's electrical production.

2. Content

The Seawing hydro-generator is delivered complete with all the components necessary for its operation. Only the following electrical cables need to be provided as they depend on your specific configuration (see details in the chapter 7 “Electrical Installation”):

- Cables connecting the electrical socket (to which the hydro-generator is connected) and the electrical box (usually located in the cabin). These are 6 multi-strand cables of 2,5 mm², the length of which you will define according to your installation.
- Cables connecting the electrical box to your battery bank: two doubled 6 mm² cables.

These cables can be purchased directly on our website www.kitewinder.fr.

Content of the Seawing pack:

- Seawing hydro-generator with 3.2 m of electric cable (6 cables of 2.5 mm²) surrounded by a Dyneema braid
- Seawing regulator box for 12-24 V or 48 V
- Connector or bulkhead connector (depending on the option chosen)
- User manual

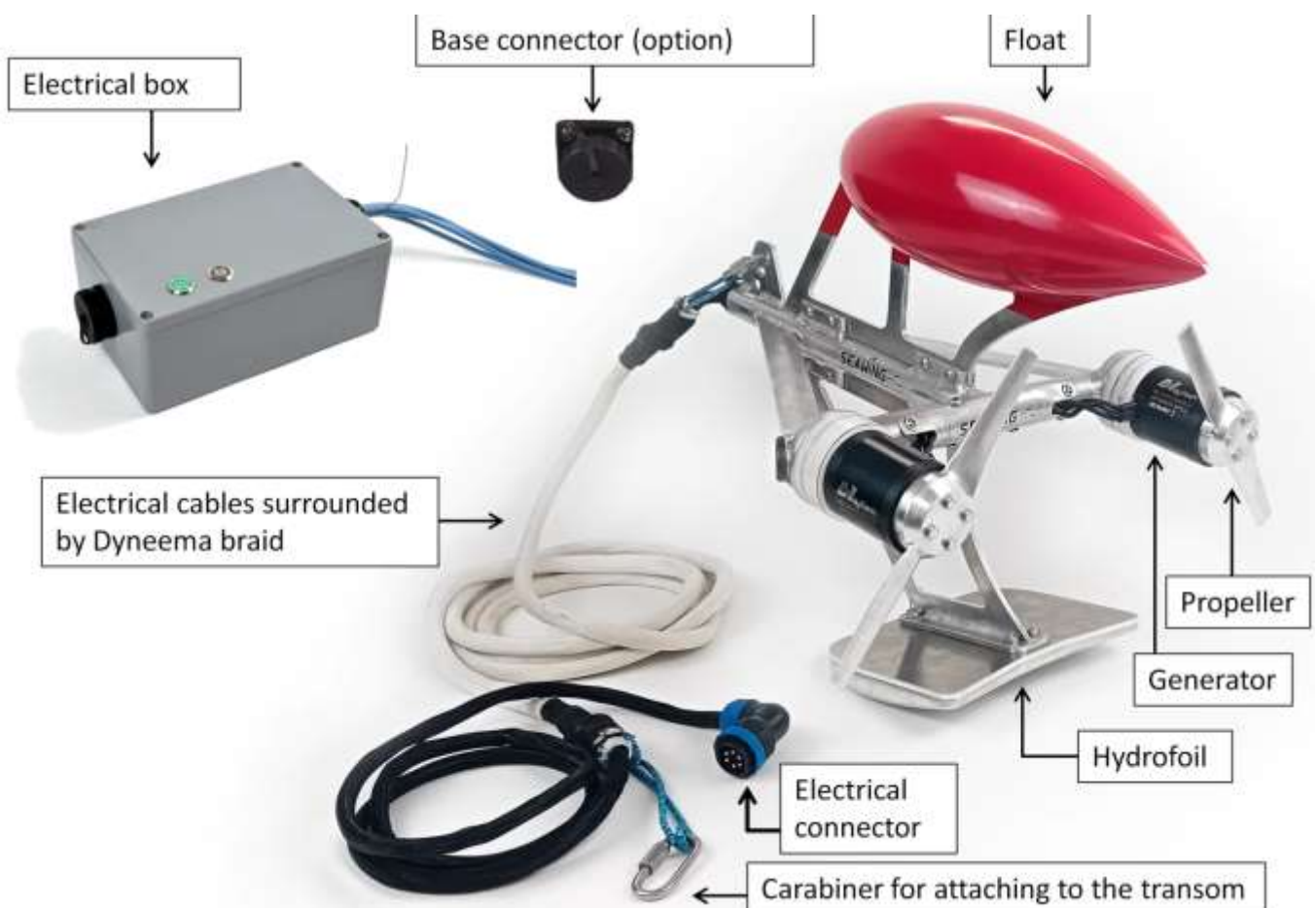

Figure 1: Content of the Seawing pack

3. Safety Precautions

The use of the hydro-generator involves some mechanical and electrical risks linked to the nature of the system.

Safety should be your first concern when installing and using the hydro-generator.

Mechanical hazards:

Do not install the hydro-generator where someone could approach the propeller.

Never try to stop the propeller while the hydro-generator is in operation.

- The hydro-generator's propellers are made of aluminum and can rotate up to 1500 rpm.
- The hydro-generator is primarily made of aluminum. Be careful when handling it to avoid dropping it. Impacts could damage the hydro-generator or the boat.
- When deploying the hydro-generator, ensure that the cable cannot entangle or wrap around you.

Electrical hazards:

Never plug or unplug the hydro-generator when the electrical box is on.

- Follow all installation instructions in this manual.
- Do not connect the hydro-generator when installing the electrical parts.
- Connect the battery last when installing the electrical box.
- Caution: during operation, the control box can reach high temperatures (50°C).
- Check the condition of the connectors regularly to ensure they are not oxidized.

4. Overall principle

The Seawing hydro-generator (1) is towed behind the sailboat. When the sailboat moves forward, the two propellers start to rotate. The propellers are directly coupled to two generators. The massive hydrofoil manages the system depth, keeping it between 0.5m and 1.5m. When the generators are operating, electricity generated by the rotating propellers passes through the towing cable. This cable is made up of electric cables and a "Dyneema" braid that surrounds them and takes up the traction force. A carabiner (2) is located at the end of the cable. It allows the hydro-generator to be attached to any existing element of the transom that can withstand the towing force (maximum traction of approximately 100kg).

The electric cable (3) of the hydro-generator is connected to the electrical box (4). The electrical box controls the hydro-generator and the charging of your battery. The output of the electrical box is then connected to your battery bank (5) 12, 24 or 48V. The control box is autonomous and will automatically stop the electrical production when the batteries are charged. The propellers is then on freewheel mode as long as the brake control is not activated by the user. Braking the rotation of the propellers allows the user to bring back the system on board by pulling the cable.

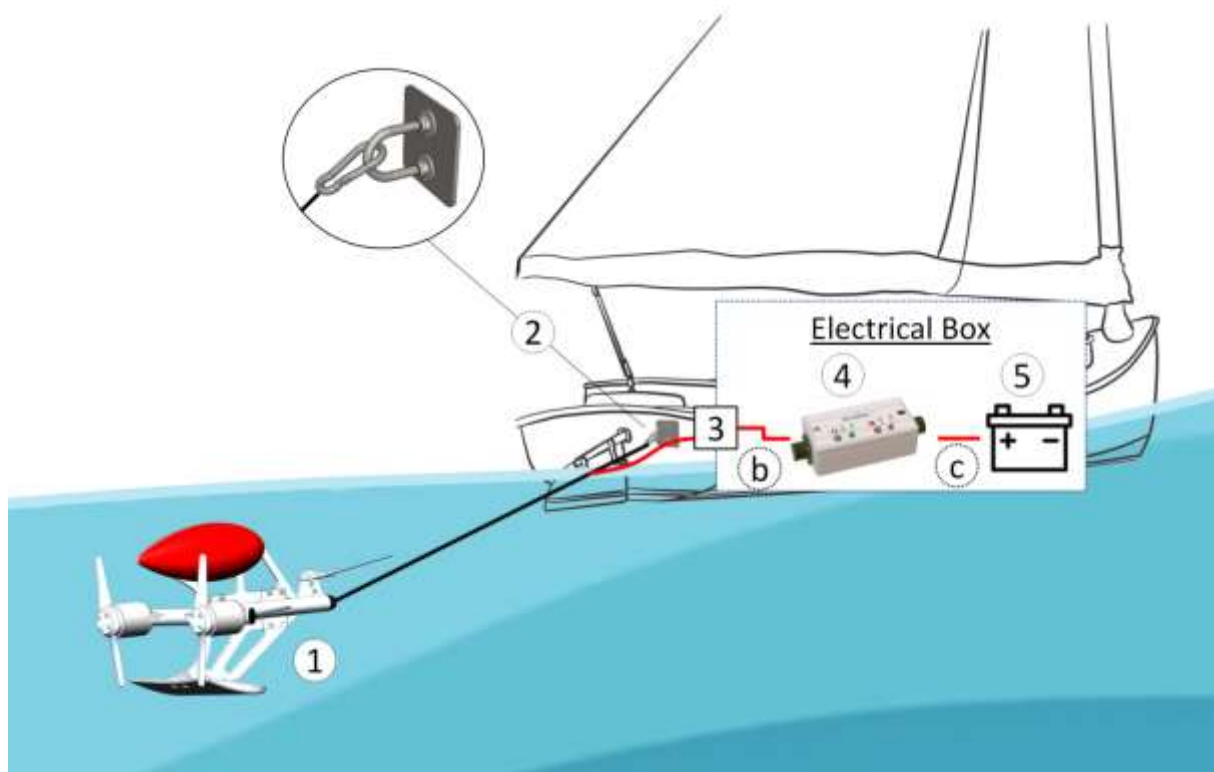

Figure 2: Overall Seawing principle

5. Specifications

Seawing Hydro-generator

Reference	Seawing
Propellers	2 aluminum propellers 240 mm
Generators	2 Brushless 3.5 kW
Electric power generation	Max 600 W
Dimensions	500*450*400 mm
Weight	6.5 kg
Length of traction cable	3.2 m
Length of electric cable between the carabiner and the electrical connector	Adapted according to your choice, by default 1 m
Position of the attachment point	Default 0.6m, max 1.3m above waterline
Minimum boat speed	3 knots
Maximum boat speed	10 knots

Seawing electrical box

Compatible batteries	Lithium-Ions, Lithium-Iron-Phosphate, Lead-Acid, Gel and AGM.
Compatible battery voltages	12V, 24V, 48V
Fuse	80 A
Dimensions in mm	187*120*178 mm
Weight	1.5 kg
Power consumption of the electrical box when switched off	0.2 mA in 24V and 0.1 mA in 12 V
Electrical cables connecting the hydrogenerator to the control box	6 cables with a section of 2.5mm ² (not supplied), in the case of configuration 1
Cables connecting the control box to the battery	2 x 6mm ² cables for the + terminal (not supplied) 2 x 6mm ² cables for the terminal - (not supplied)

Note: For Gel and AGM Lead-Acid batteries, the charge limit in amps is: Battery capacity/10. This therefore limits the power produced. So for a 12V, 100Ah battery, the power limit will be $14.4 \times 100 / 10 = 144$ Watts.

Performance curve:

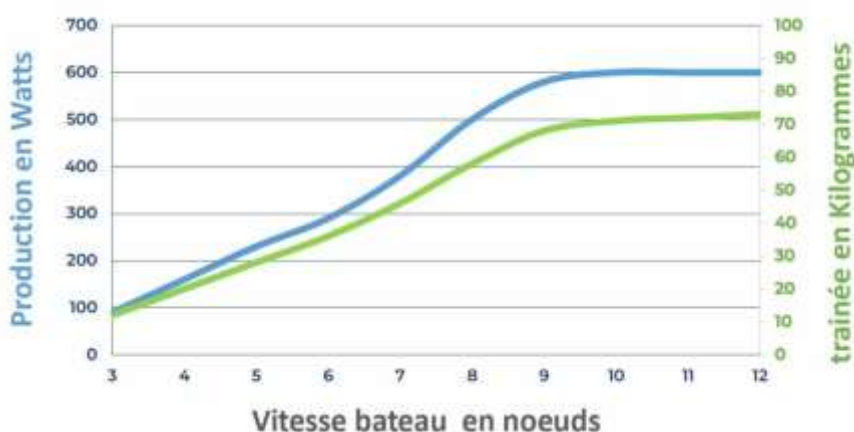

6. Mechanical setup

We designed the hydro-generator to minimize its drag. It can therefore be attached to any existing part of the transom capable of withstanding the drag force generated by the two propellers. In practice, it is necessary to use an attachment point capable of withstanding a tension of at least **150 kg**. This attachment point should, if possible, be at a height above the water of approximately **0.6 m** (maximum 1.3 m). If it is higher, the hydro-generator may be too close to the water surface (especially at high speed) and the electrical production will be impaired. We recommend attaching the hydro-generator towards the center of the transom to minimize the effects of the boat's heel on the hydro-generator.

Note: You can easily attach the hydro-generator to the port or starboard side depending on the direction of the boat's tilt.

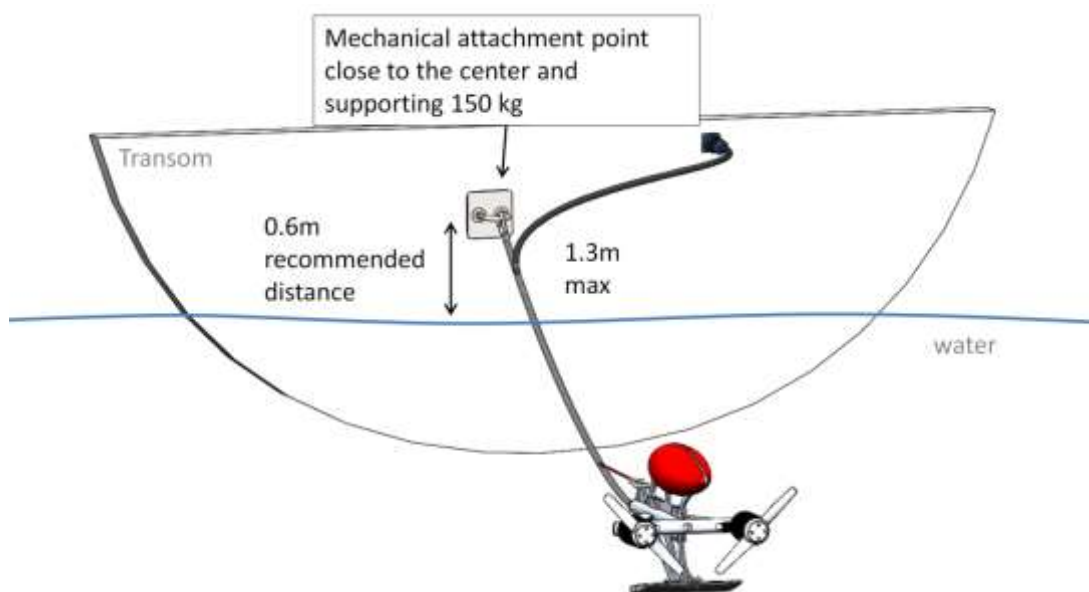
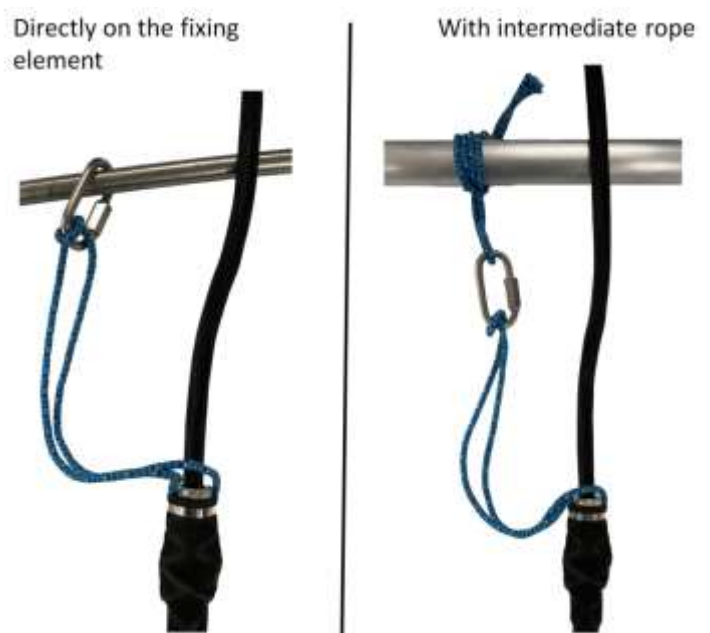

Figure 3: Attachment point on boat's transom

Use the hydro-generator's carabiner to attach it to the chosen attachment point.

If the fixing element is too big to fit into the carabiner, use a rope as an interface (the rope must have a tensile strength greater than 300 kg, generally a minimum diameter of 4mm is required).



7. Electrical setup

The general connection principle is shown on the Figure 4.

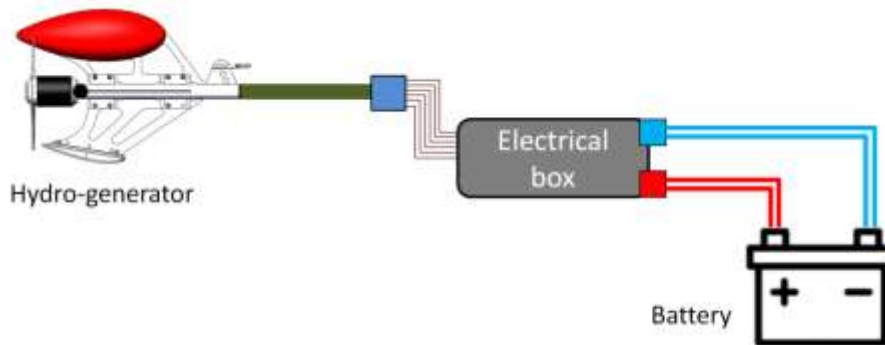

Figure 4: Connection principle

Two types of installation are possible. If you wish to install the electrical box permanently in the cabin, refer to the chapter 7.1 (configuration 1). If you do not wish to install the electrical box permanently in the cabin, refer to the chapter 7.2 (configuration2).

7.1. Configuration 1: In-cabin electrical box option (through bulkhead)

This option should be chosen if you wish to permanently install the electrical box near your electrical system and battery bank. This is the option we recommend.

Your electrical installation is inside the boat. You will therefore need a bulkhead connector to connect the hydro-generator and the control box. This connector is provided if you have selected this option.

Refer to the chapter 6 “Mechanical Installation” to choose the attachment point you will use. This choice must be made before choosing the location of the connecting base.

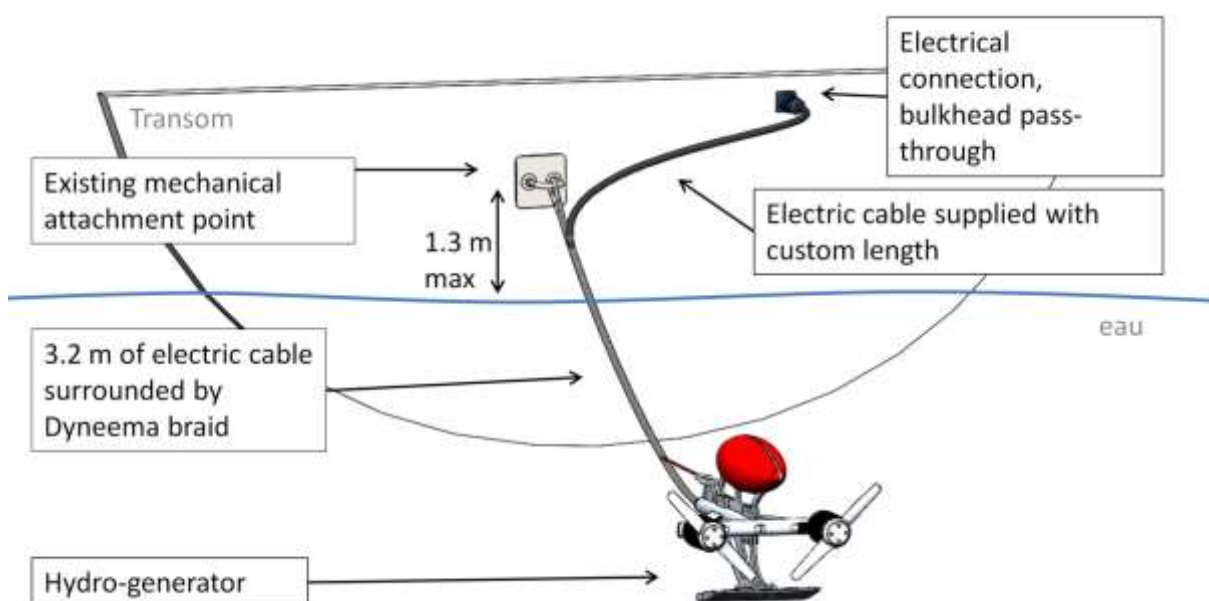

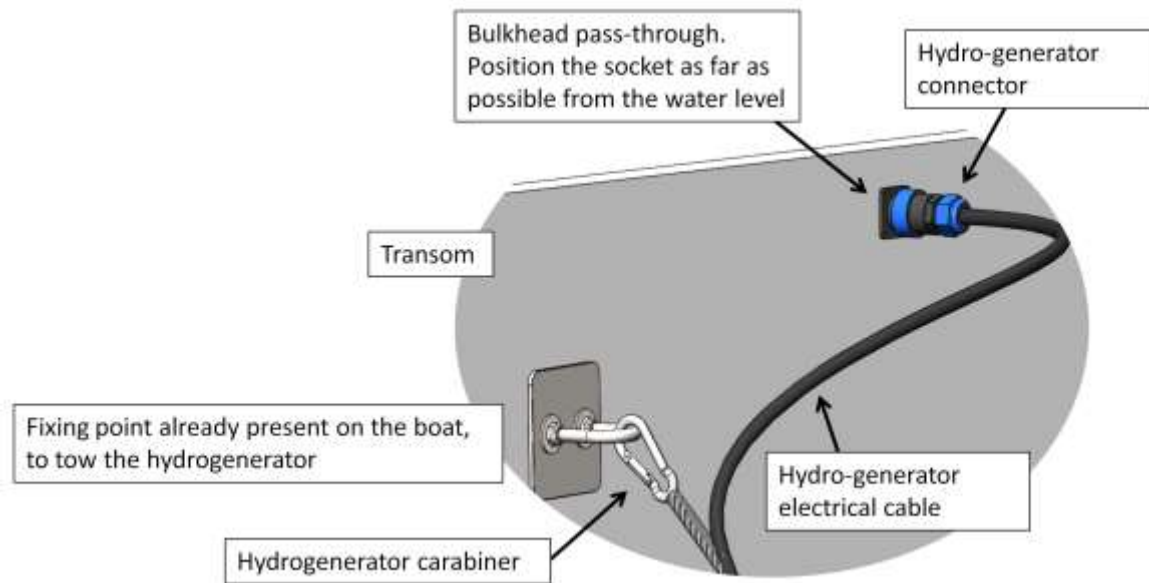

Figure 5: Bulkhead pass-through and connection principle

Installation of the connecting base:

The fixed baseplate must be placed close to the hydro-generator attachment point and as far as possible from the water level.

The length of the electrical cable that you have chosen (depending on your installation) must be specified to us when purchasing the Seawing hydro-generator.

We give you a drilling template with the central hole and the position of the 4 fixing screws.

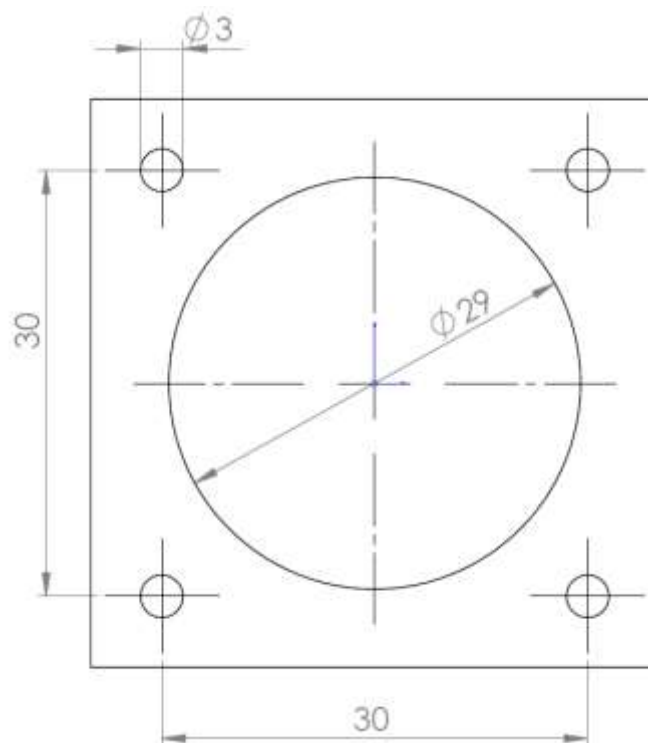

Figure 6: Drilling template

There are two fixing possibilities:

- with self-drilling screws (supplied). The hull must not be less than 5 mm thick so that the screws do not go completely through the hull.
- with 25mm through screws and nuts (supplied). The hull can then have a maximum thickness of 15mm. However, you can use longer screws if your hull is thicker. In this case, you will need to make the electrical connections on the connector before fixing it to the hull (see electrical connection on p12 and p13).

Drill the **29 mm diameter** central hole at the location chosen for the connection. You can use the template provided if necessary.

We supply an EPDM seal to be placed between the bulkhead connector and the outside of the hull to ensure a watertight seal.

Then fix the base (with the EPDM seal):

- by screwing the 4 self-drilling screws
- or with the 4 M3 screws and their nuts (you will then need to drill the 4 screws locations with a 3mm diameter drill bit)

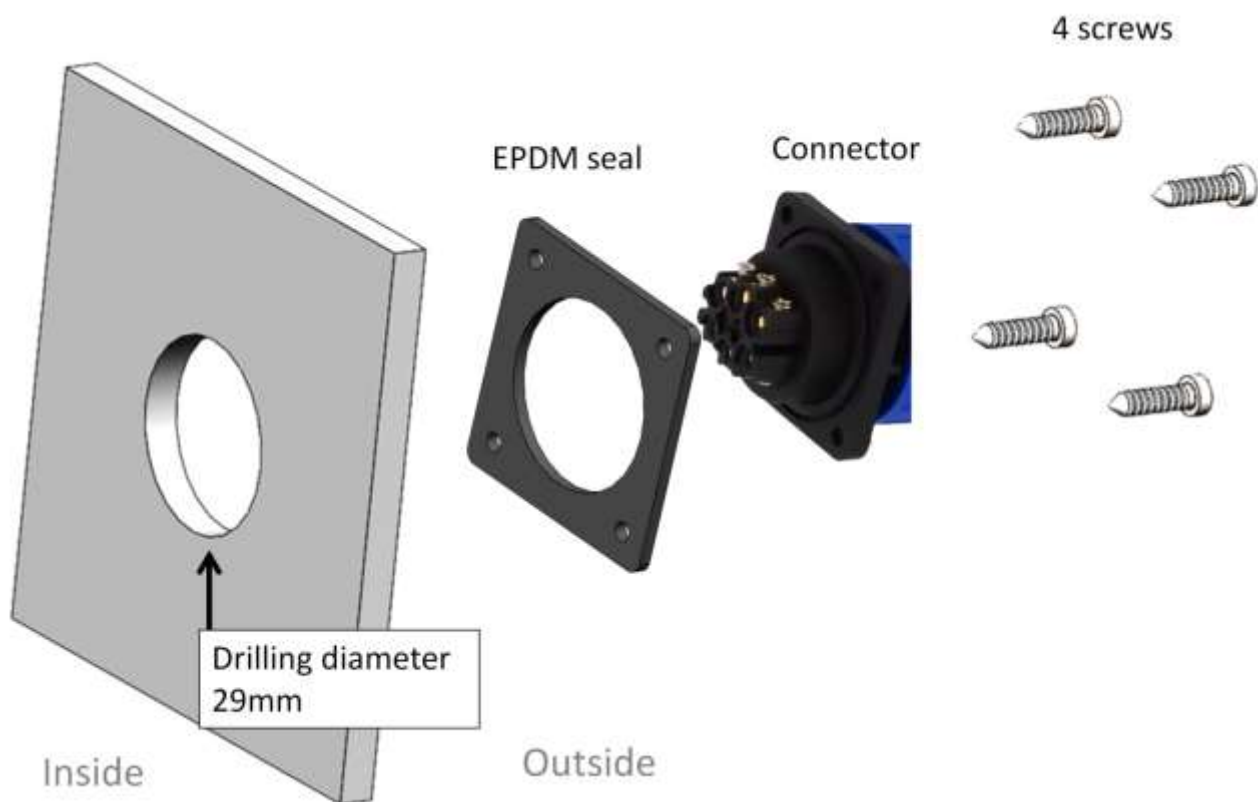

Figure 7: bulkhead connector installation

Electrical connections:

The configuration is as follows:

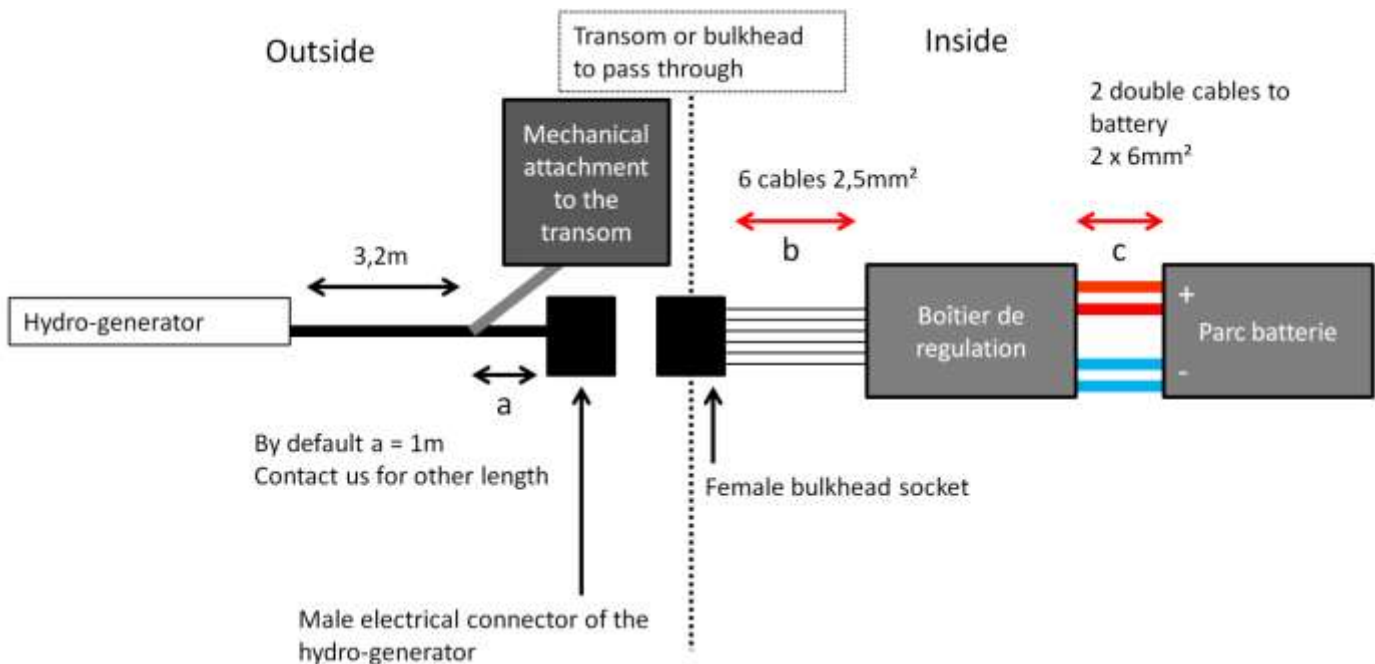

Figure 8: Electrical principle

To connect the bulkhead connector to the electrical box, you must purchase:

- 6 multi-strand cables with a cross-section of 2.5 mm^2 for the connection between the base connector and the electrical box. This is length "b" in the previous diagram. This length must not exceed 10 meters.

To connect the electrical box to the battery, you must purchase:

- 4 cables with a cross-section of 6 mm^2 (two for the positive terminal and two for the negative terminal). This is length "c" in the previous diagram. This length must not exceed 6 meters.

For assembly, you will need:

- Phillips screwdriver for making electrical connections.
- Tools required to set the electrical box in position (this is your responsibility). Position this box close to the rest of your electrical installation, particularly your batteries. Be careful: the box can reach 50°C during operation. Leave space all around the box to ensure good ventilation.

Installation of the cable connecting the bulkhead connector to the electrical box:

Bulkhead connector side:

- Locate plug numbers 1 to 6.
- Connect your 6 cables (2.5mm² cross-section) to them, carefully marking the corresponding numbers on your cables.



Figure 9: Installation of the 6 cables on the bulkhead connector

Electrical box side:

Run your 6 cables to your previously installed electrical box.

- Identify the numbers of the different cables coming out of the box (see labels).
- Connect your 6 cables using the supplied terminal blocks.

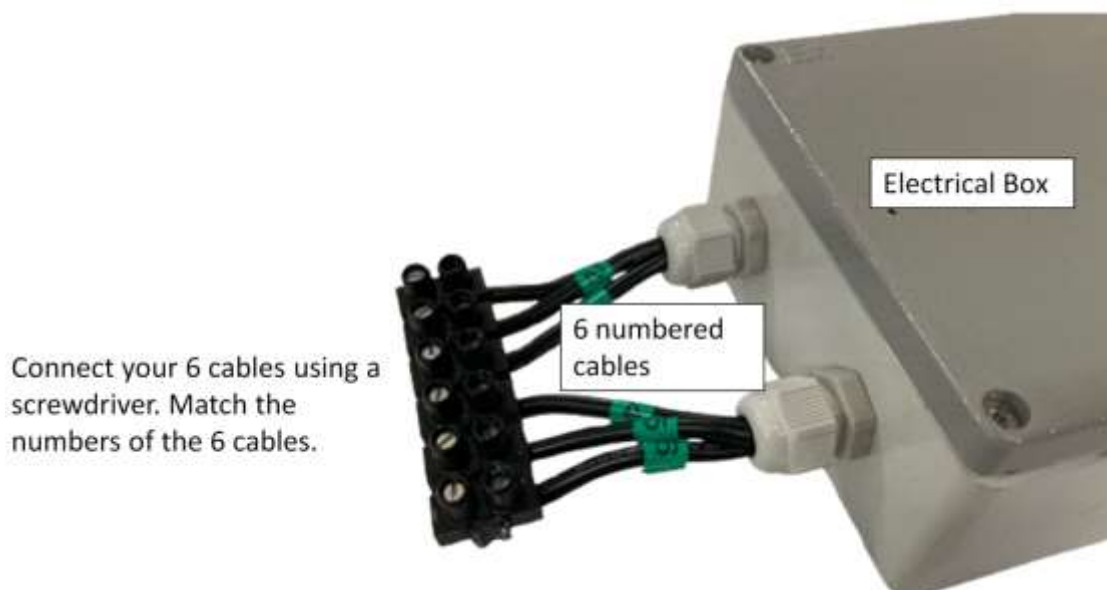

Figure 10: Connecting the 6 cables to the dominos

7.2. Configuration 2: Mobile electrical box option (direct connection)

If you choose this option we will deliver the electrical box directly equipped with the female socket to which to connect the hydro-generator.



Figure 11: Hydrogenerator directly connected to the electrical box

This installation does not require drilling into the hull. Simply connect the male plug of the hydro-generator to the female plug of the electrical box. As standard, we deliver the hydro-generator with 1m of additional electrical cable beyond the mechanical attachment point. We can provide you with a maximum of 3m of electrical cable.

If your battery is far from the transom, then the connection cables between the battery and the electrical box will probably be long (we recommend a maximum of 6m).

⚠ Do not place the electrical box in direct sunlight.

7.3. Connecting the electrical box to the batteries

Please note: the electrical box is equipped with an 80A fuse. You do not need to install a circuit breaker between the electrical box and your batteries.

You need to get the following cables:

2 doubled cables 2x 6mm² for the connection between the electrical box and your battery bank. You must measure the necessary length between the location of your batteries and the electrical box. This length must not exceed 6m. There will therefore be 2 cables to connect to the (+) terminal and 2 cables to connect to the (-) terminal. These doubled cables limit the cross-section to be used.

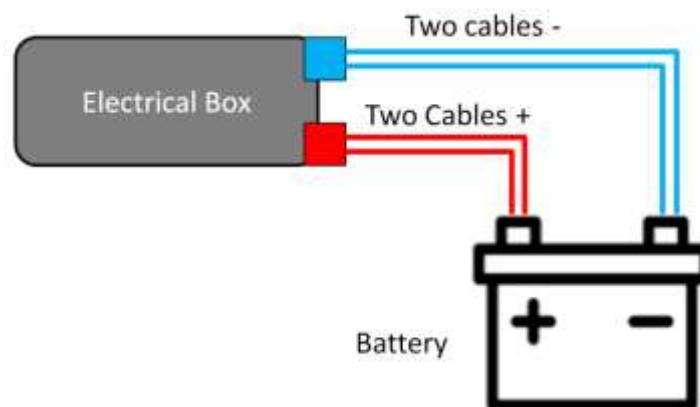

Figure12: Connection to the battery, 2 cables 6mm² (+), 2 cables 6mm² (-)

Open the cover of your electrical box by unscrewing the 4 screws on the top. Be careful, cables connect the buttons on the cover to the electronic boards. You will need to have access to the orange tabs located on the bottom electronic board. You can disconnect the two controllers labeled 1 and 2 if necessary. These electronic boards are each used to control a propeller (see chapter 11 Figure 30).

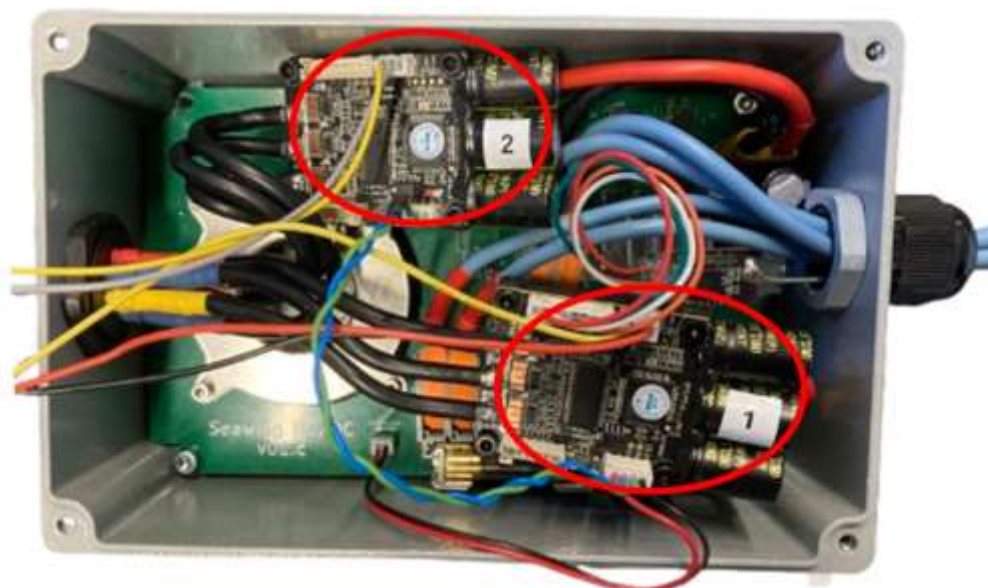

Figure 13: Complete electrical box with both labeled controllers

Move the top boards to access the orange tabs, locate the (+) and (-). Lift the tabs.

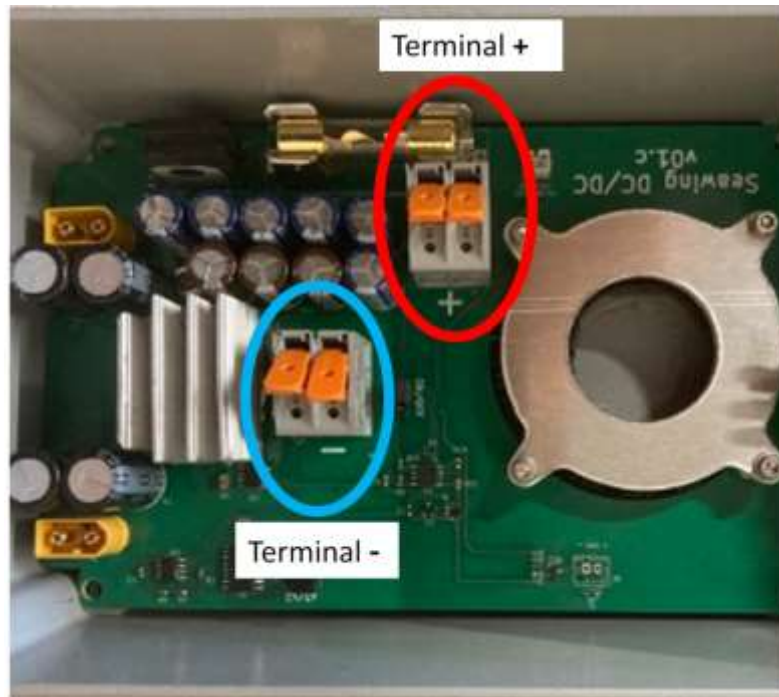

Figure 14: Lift the tabs to connect the 6mm² cables

Pass your 4 wires through the cable gland provided for this purpose. Connect your two wires to the (+) terminal of the box by sliding them in and then closing the tab. Make sure they are secure. Connect these two cables to the (+) terminal of your battery. Then connect the two remaining wires to the (-) terminal of the box by sliding them in and closing the tab. Connect these two cables to the (-) terminal of your battery.

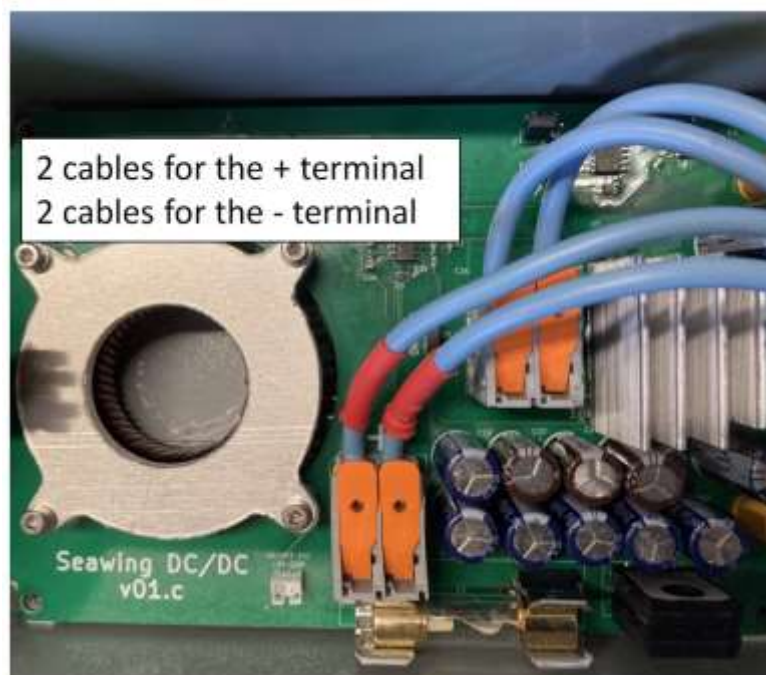

Figure 15: Connecting the battery cables in the electrical box

Bluetooth antenna:

Put back in place the electronic cards in the box.

Locate the antenna and Bluetooth card. Pass the antenna through the cable gland with the cables connected to the battery. This antenna must be well out of the box for the Bluetooth connection to work correctly. Screw the cable gland so that the cables no longer slide. Close and screw the electrical box cover in place.

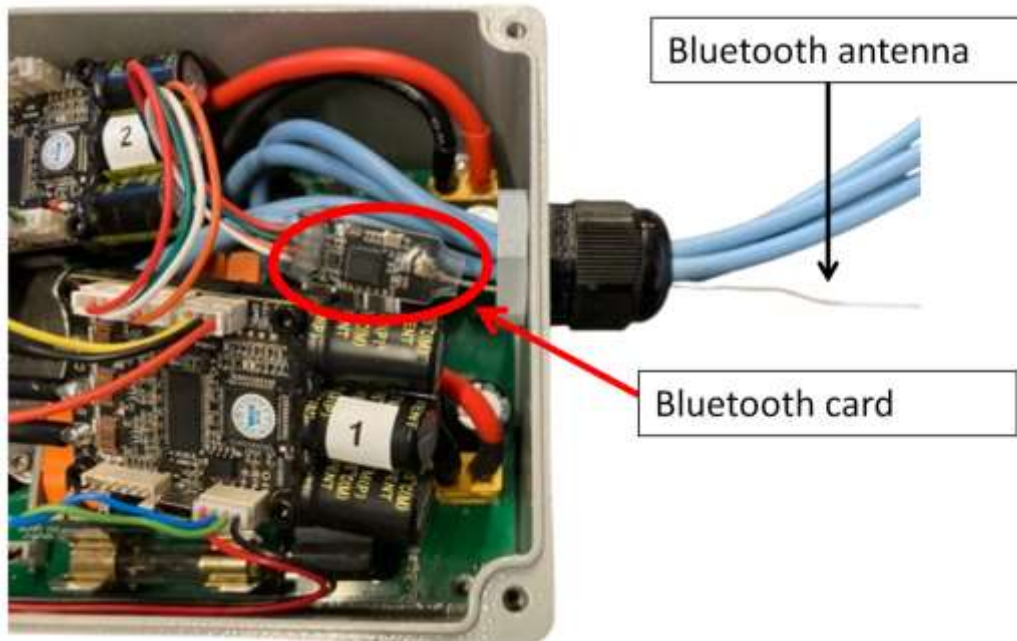

Figure16: Bluetooth antenna coming out of the electrical box

8. Installation and configuration of the electrical box

8.1. Battery voltage

⚠ Never operate the jumpers while the electrical box is connected to the battery. Disconnect the box from the battery before any work.

⚠ Incorrect configuration of the jumpers can destroy the electronics in the electrical box.

48 V boxes are not affected by this manipulation: they can only manage 48 V.

We supply your electrical box already configured to your battery according to the information provided at the time of purchase. However, you can check or change the output voltage of the box as follows:

- Disconnect the battery pack. Turn on the battery pack with the **ON** button to drain the capacitors. Proceed to the next step when once the button light turned off.
- Open the case by unscrewing the 4 screws on the cover
- Move the top electronic cards to see the bottom card
- Locate the 12V/24V “jumper” on the electronic board located at the bottom of the box (see photo below):



Figure 17: Seawing electronic card and jumpers

Remove and place the jumper to obtain the desired configuration:

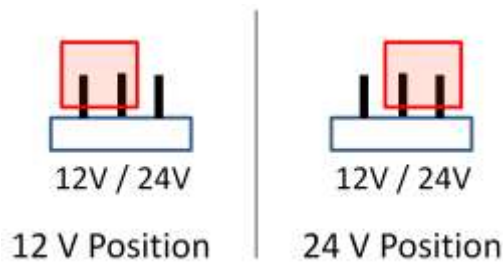

The 12V configuration is suitable for 12V lead-acid batteries and 12V lifePo4 batteries.

The 24V configuration is suitable for 24V lead acid batteries and 24V lifePo4 batteries.

8.2. Bluetooth application settings

The smartphone application communicating via Bluetooth with the electrical box allows you to view important data in real time, such as the power produced, battery voltage, etc. It also allows you to configure the electrical box and update the firmware. This application is, however, optional: we have configured your electrical box based on the information you provided during purchase.

Download the app for Android or iPhone: VESC Tool. The app cost about 4 euros.

https://vesc-project.com/vesc_tool

Launch the application and activate your Bluetooth on the smartphone.

Turn on your electrical box by pressing **ON** (the box must be connected to the battery). Perform a Bluetooth scan: "**Scan BLE**" on the app. You should see a Bluetooth device named VESC. Connect to it.

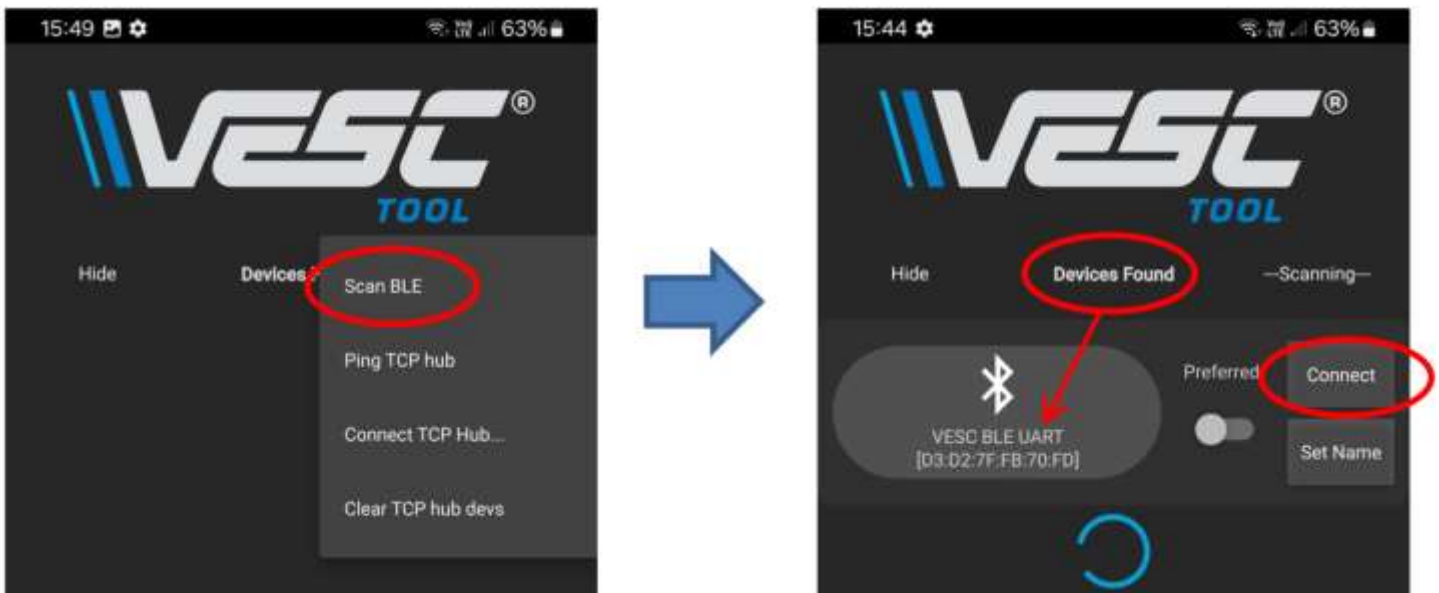

Figure 18: Bluetooth connection to the box

Setting up the electrical box via the Bluetooth application:

Scroll through the top menus by swiping to the right until you reach the "**SETUP**" menu, click on it. You can then change the following settings:

- In "**Battery type**", select the type of your batteries: Lithium-Ion, Lithium-Iron (Lithium Iron Phosphate), Lead-acid (Lead Acid).
- In "**Battery Cell Series**", enter "**4**" for 12V batteries and "**8**" for 24V batteries.
- In "**Battery Capacity**" enter the capacity of your battery in Ah.

For lead acid, gel and AGM batteries, the charge limit of the hydro-generator is C/10. So for a 12V and 100Ah battery, the power limit will be $14.4 \cdot 100 / 10 = 144$ Watts.

- In "Wheel Diameter", enter the approximate length (in mm) of cable between your electrical box and the batteries.

Click on **“Write”** to have these values transferred and saved on the electrical box.

You can then click **“READ”** to verify that the information has been updated. Then turn off the electrical box by pressing the **OFF** button on the box.



Figure 19: Setting up the box via the application

8.3. Firmware update

It is possible to update your electrical box via the Vesc Tool Bluetooth application. See chapter 8.2 “Bluetooth Application Settings”.

Download the latest firmware version from our website www.kitewinder.fr. To continue, this file must be present on your smartphone.

Open the app, press **ON** to turn on the electrical box (it must be connected to your batteries) and connect via the Bluetooth app (see Figure 18).

On the main screen, scroll down and click on “**FIRMWARE**”.

Click on “**Choose File**” and select the update file you downloaded (.bin file).

Start the update by clicking on “**upload**”. Once the update is complete, wait ten seconds and then turn off the control box.

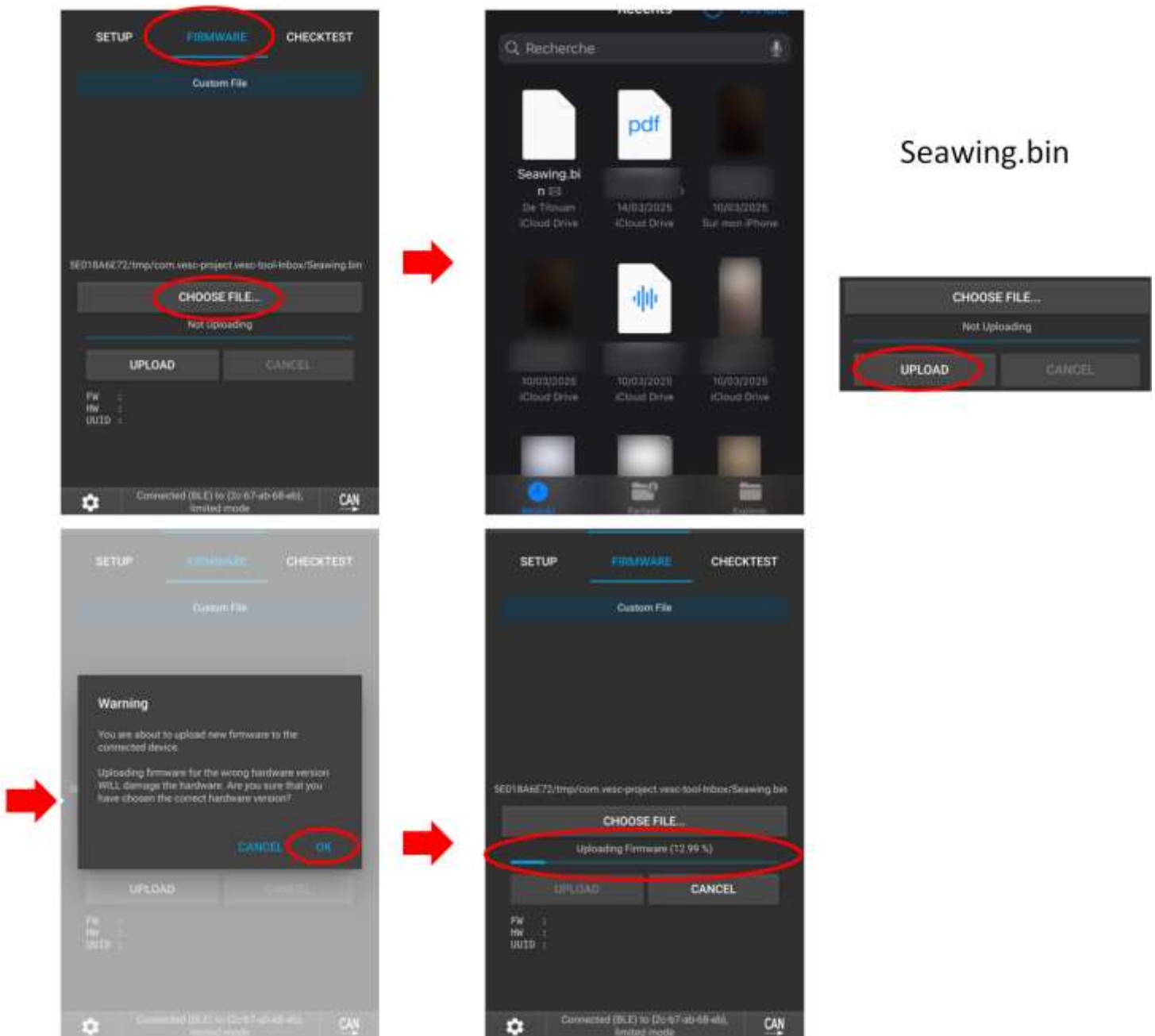

Figure 20: Update firmware

9. Use of the hydro-generator

9.1. Putting the system into water

⚠ Never connect the hydro-generator when the electrical box is switched on.

Electrically connect the hydro-generator to your electrical box (or to the previously installed base connector). Attach the hydro-generator's carabiner to your attachment point. Check that your electrical box is properly connected to the battery bank.

Once the hydro-generator is electrically connected to the electrical box, turn it on with the **POWER** button (the button lights up). The **STOP** button on the control box must be disengaged.

Check that the hydro-generator cable is not tangled and that it will unwind without getting caught on objects or hindering you. Launch the hydro-generator into the water.

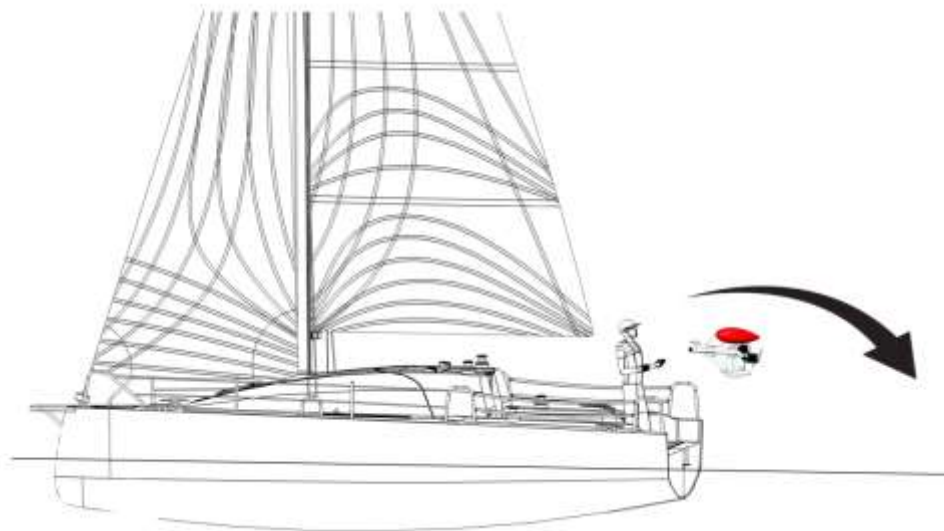

Make sure that the electrical cable is not subject to any tension:

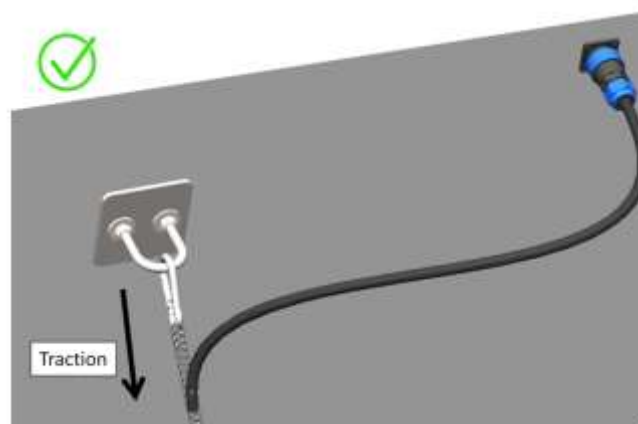

Figure 21: No tension on the electrical cable

9.2. Operation

Check that the **STOP** button on the electrical box is not engaged. Check that the electrical box is turned on (**POWER** button lit). As soon as the boat speed reaches 3 knots, the hydro-generator propellers start rotating. Electricity production then begins and charges your batteries automatically.



Figure 22: ON button is lit, stop button is not engaged

You can control the electricity production with your smartphone via the Bluetooth application (see chapter Bluetooth Application Settings 8.2). Open the Vesc Tool app. Connect to your hydro-generator. Go to the "**SEAWING**" tab.



Figure 23: Real-time monitoring

You can see in real time:

- the rotation speed of the propellers (1)
- the electrical production in Amperes (2)
- the power produced in Watts (3)
- the battery voltage in Volts (4 and 5).

9.3. Adjusting the depth of the hydro-generator



Figure 24 : The 3 positions of the carabiner

You can adjust the depth of the hydro-generator by changing the position of the carabiner:

Position 1: default position, the depth of the hydro-generator is standard.

Position 2: the hydro-generator will be less deep than in position 1.

Position 3: the hydro-generator will be less deep than in position 2.

9.4. Getting the system back

 **Never unplug the hydro-generator when the electrical box is on.**

The electrical box automatically detects when the batteries are charged. The hydro-generator then stops producing electricity. The hydro-generator goes into "freewheel" mode. We recommend bringing the hydro-generator back on board when it is no longer producing electricity.

You can remove the hydro-generator from the water at any time: press the **STOP** button on the electrical box. This will brake the rotation of the propellers and allow you to bring the hydro-generator back on board by pulling the cable. Press the **POWER** button to turn off the electrical box. Once the box is off, you can unplug the hydro-generator and remove the carabiner from your attachment point. We recommend rinsing the generators with fresh water before storing the hydro-generator until its next use. Return the **STOP** switch to its unengaged state.



Figure 25 : STOP button

9.5. Testing the hydro-generator via Bluetooth

You can test the correct operation of the hydro-generator out of the water using the Bluetooth application (See chapter Bluetooth Application Settings 8.2). This test will slowly rotate the propellers. Position the hydro-generator so that nothing is preventing the propellers from rotating.

Press the **ON** button to turn on the electrical box. Check that the **STOP** button on the box is not engaged.

Connect to the Bluetooth app and go to the “**CHECKTEST**” menu.

Press “**RUN TEST**”, the propellers will then turn slowly. If one or both do not turn, please contact us. Also check that the propellers are turning in the correct direction (see chapter 11 Figure 30).

To end the test, press “**STOP TEST**”. Wait until the bottom banner (in blue) says “**App config write OK**” before exiting the application.



Figure 26 : Generator Test

10. Care and maintenance

We designed the Seawing hydro-generator to be as robust and resistant as possible to the marine environment. The metal parts are made of A4 stainless steel (316 stainless steel) or marine-grade aluminum. We recommend that you have it serviced by us every two years or 10,000 nautical miles.

You have to change the two anodes (located on the propellers) when it appears heavily corroded or if it is less than half its original thickness (see Figure 29). You can buy new anodes in our website www.kitewinder.fr

Here is how to maintain your Seawing:

- Flush the system with fresh water regularly (ideally after each use when bringing the system back on board).
- Regularly inspect the tightness of visible screws.
- Check that there are no signs of impact on the hydro-generator.
- Regularly inspect electrical connections to ensure they are not corroded (otherwise replace the connection). The connection located outside the cabin should be given special attention.
- Regularly inspect the hydro-generator's electrical cable, check that it is not cut or damaged.

Checking the electrical installation

- Check that the electrical box is securely attached.
- Check that air circulates well all around the box (that nothing is obstructing it).
- Remove any dirt and dust that may be present on the electrical box.
- Check that the terminals are properly tightened. Inspect the connections, their tightness, and the absence of corrosion.

11. Disassembly

All the screws used on the hydrogenerator are made of A4 marine stainless steel. All screws and nuts are fitted with plastic washers (except for the screws securing the generators). The plastic washers act as insulation between the screw or nut and the aluminum parts (to prevent galvanic corrosion). The screws can be unscrewed with Allen keys (not supplied) and the nuts with open-end wrenches (not supplied).

You can easily disassemble the float and the stabilizer by unscrewing the screws. Keep the nylon plastic washers and self-locking nuts for reassembly. The disassembled hydrogenerator takes up less space.

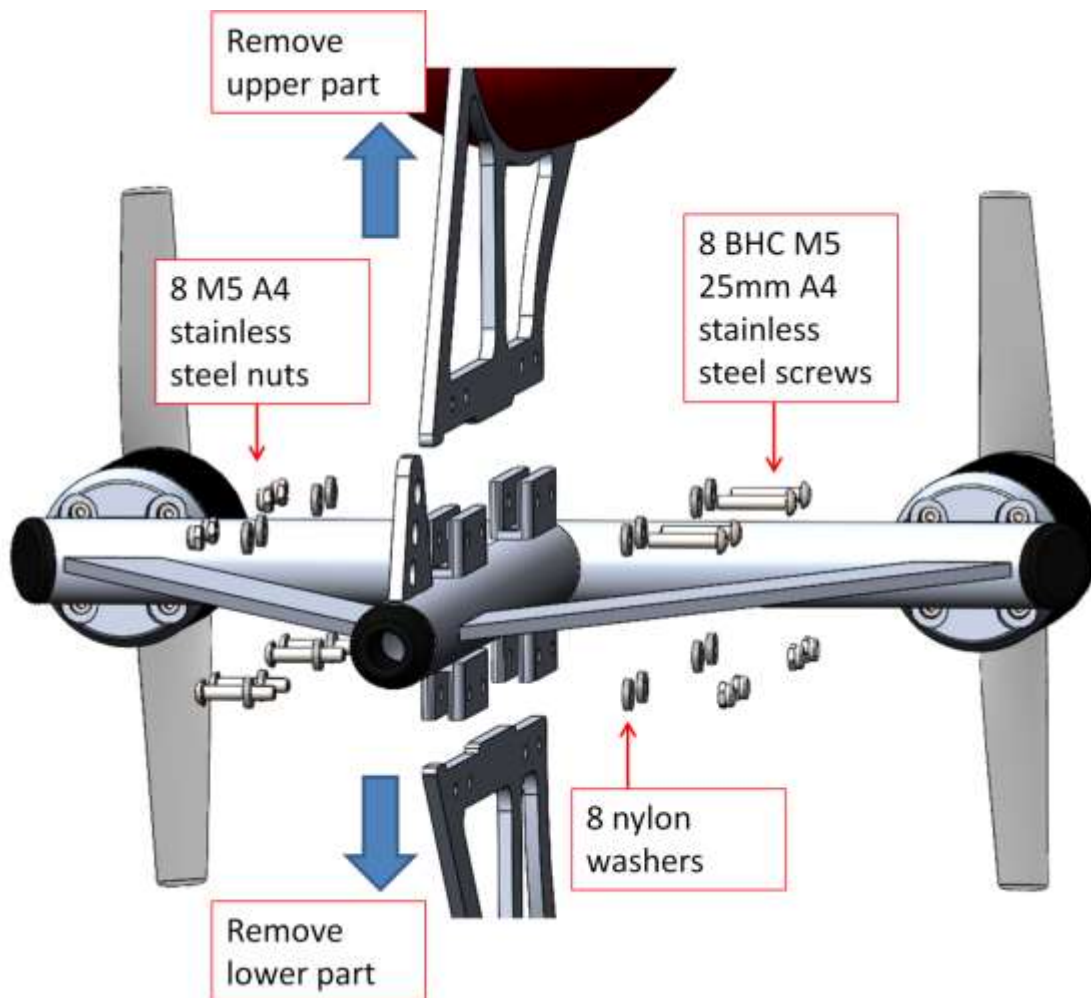

Figure 27: Disassembly of the float and the hydrofoil

You can also disassemble the massive aluminum hydrofoil by unscrewing the 4 fixing screws.

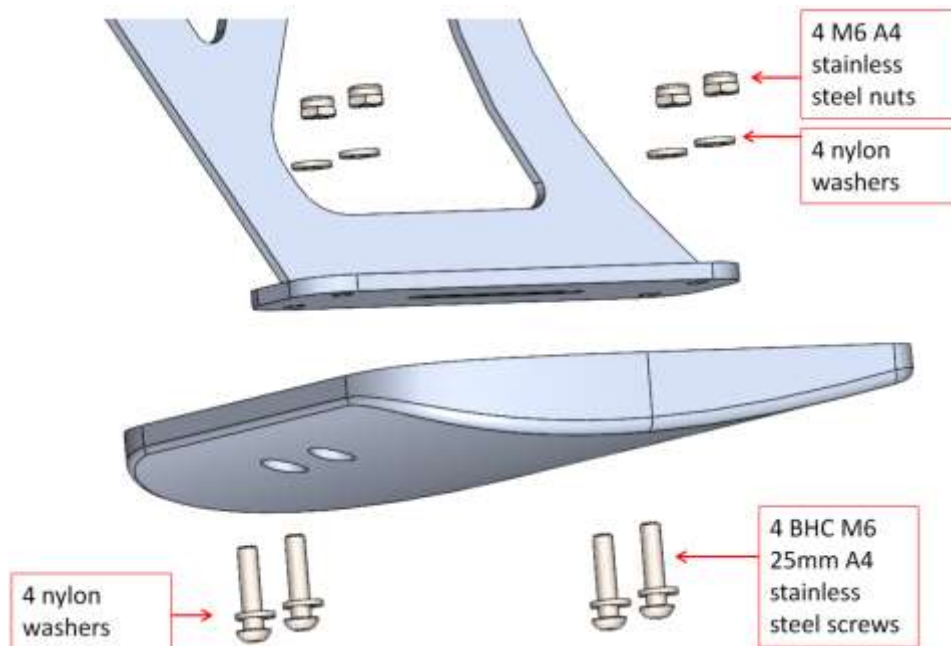

Figure 28: Disassembling the hydrofoil

You can disassemble the generator, propeller and anode using Allen keys and open-end wrenches.

Change the anode if it appears heavily corroded or if it is less than half its original thickness.

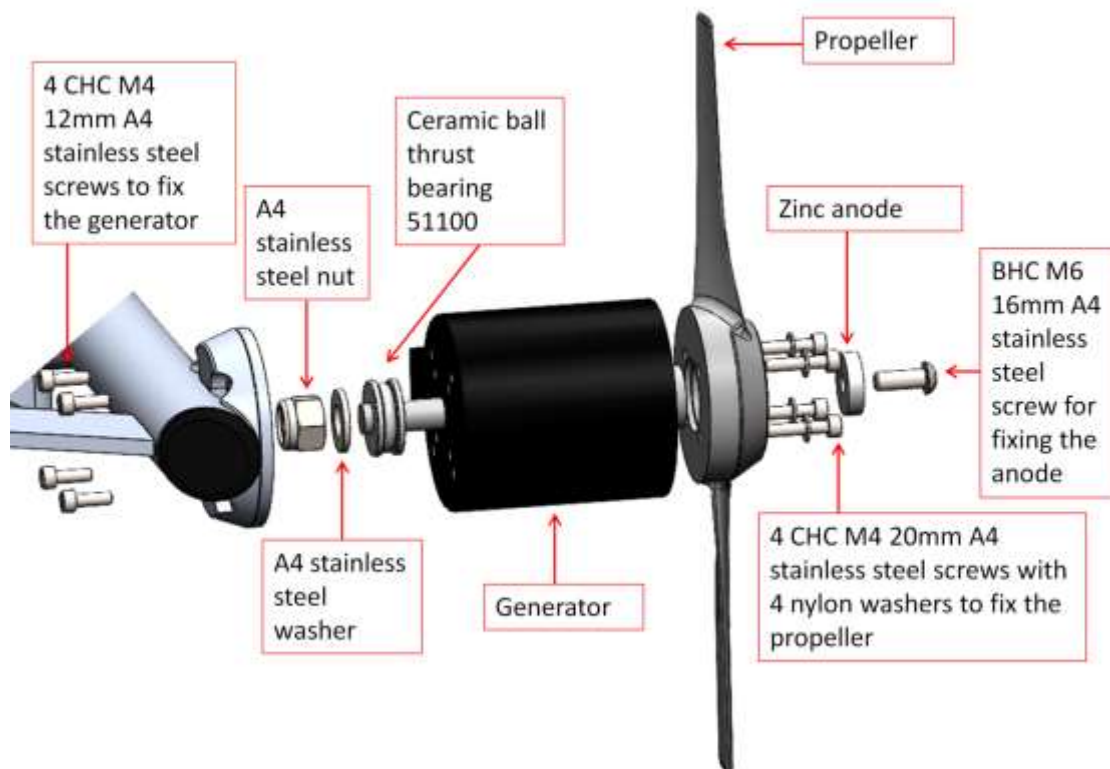

Figure 29: Disassembly of the generator, propeller and anode

Be careful when reassembling the propellers, the clockwise one is located on the left (when looking at the system from behind) and the counterclockwise one is located on the right. The left propeller is associated with electronic card n°1 and the right propeller with electronic card n°2. The engravings on the propellers indicate the direction of rotation and the position of the propeller:

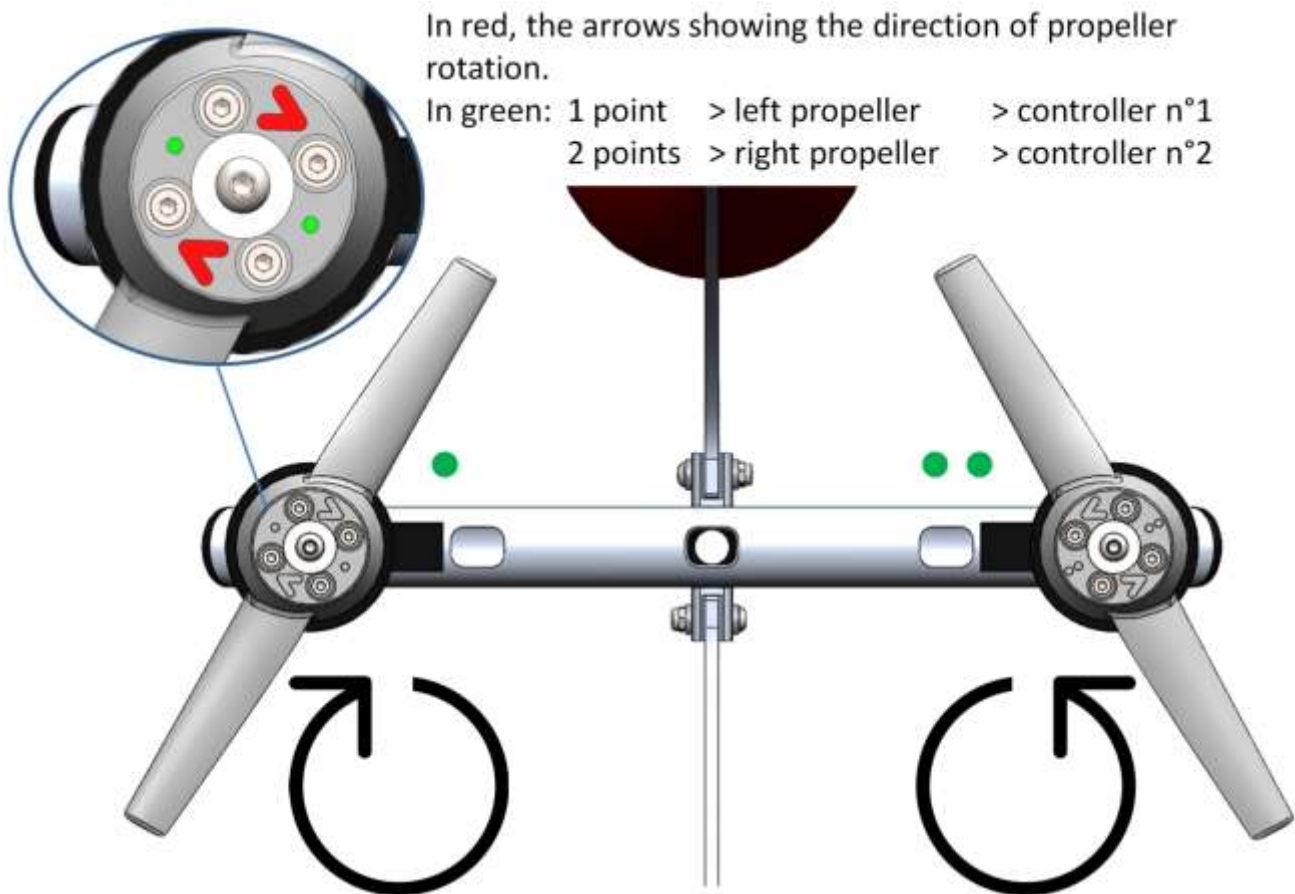

Figure 30: Direction of rotation of the propellers

12. Warranty

The Seawing hydro-generator is intended for a specific use, and the user must ensure proper use of the product. The system is guaranteed for 2 years from the date of purchase against any manufacturing defects. The complete hydro-generator or defective parts will not be refunded, but only repaired or replaced.

The warranty includes the replacement of defective components or, if necessary, the entire system. The purchaser must prove that the alleged hidden defect existed prior to the date of purchase.

The following information must be included when returning the product under warranty: name, address, date of purchase, boat reference, defective component, description of the manufacturing defect encountered, conditions under which the hydro-generator was used.

Shipping costs for defective parts are the responsibility of the purchaser. If, after Kitewinder's analysis, the parts are covered by the warranty, then these costs will be refunded.

The warranty does not apply if:

- the system was damaged during use, suffered a shock
- The buyers made modifications to the system
- the system was improperly installed or maintained
- the system was used under too strong conditions (loads too high)

The warranty does not cover normal wear and tear of the hydro-generator.

Kitewinder is not responsible for any special, incidental or consequential damages.

If you encounter any problems, please contact us.

We wish you a good use !

Kitewinder

www.kitewinder.fr

1 Allée Jean Rostand

33650 Martillac

France

o.normand@kitewinder.fr

+33603888252