



Why choose an atlas[™] davit?

Designed and produced by the world class team at Jeremy Rogers Ltd, builders of fine yachts, **atlas** is the world's leading manufacturer of carbon fibre marine davits.

We combine the latest technology and materials with a simple yet elegant design to produce the definitive lifting solution for the boating world.

Whether you are lifting jet tenders or rescue boats, jetskis or slides, the **atlas** carbon davit range will have something to suit your needs.

Our exclusive, tried and tested, METS-DAME award winning range of lightweight davits have a number of different applications and are currently used all around the world – on superyachts, on dock sides and by the UK Ministry of Defence for man overboard safety.

Most of our davits can be class approved to meet man overboard, man riding and rescue launching standard. Working closely with leading IACS Classification Society RINA and the Cayman Islands Shipping Registry we are also now able to offer certification to meet the new coding requirements for man-riding (CISN 01/2022) under the REG Yacht Code.

- ➔ **Portable – starting from 11kg**
- ➔ **Strong – lifting up to 1000kg**
- ➔ **Available in a range of sizes**
- ➔ **Rotates through 360 degrees**
- ➔ **Quick and simple to erect and use**
- ➔ **Moveable – use in multiple deck positions**
- ➔ **Easily stowed**
- ➔ **CE approved and ISO9001**
- ➔ **METS-DAME award winner**
- ➔ **The only carbon davit brand certifiable for man-riding**

Standard davit[™] With electric winch

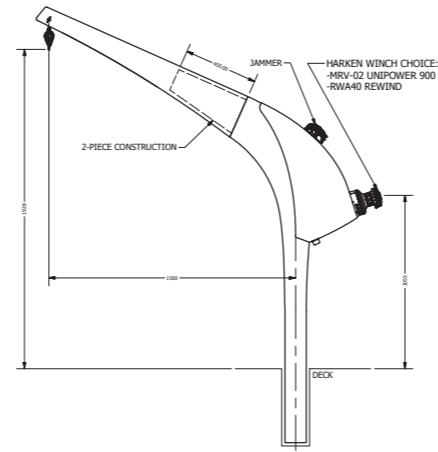

**Safe working load (SWL)
= 500kg**

Reach:	1500mm
Weight:	from 55kg*
Height under hook:	1930mm
Reach:	2000mm
Weight:	from 60kg*
Height under hook:	2150mm
Reach:	2500mm
Weight:	from 70kg*
Height under hook:	2370mm
Reach:	3000mm
Weight:	from 75kg*
Height under hook:	2600mm
Reach:	3500mm
Weight:	from 85kg*
Height under hook:	2820mm
Reach:	4000mm
Weight:	from 90kg*
Height under hook:	3040mm

Technical specifications

Socket depth in deck: 450mm
 Socket internal diameter GRP, aluminium, stainless steel: 155mm
 Electric winch: 12/24 volt
 Bearings: plain polyester (optional roller bearing)
 Construction: advanced pre-preg carbon fibre

* Actual davit weight defined by selected specification. We reserve the right to alter technical specifications without prior notification.

Standard davit[™] With manual winch

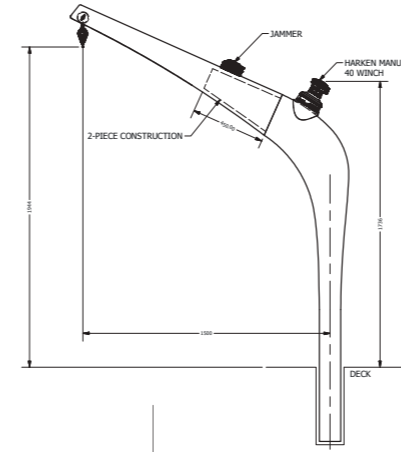

**Safe working load (SWL)
= 500kg**

Reach:	1500mm
Weight:	from 45kg*
Height under hook:	1930mm
Reach:	2000mm
Weight:	from 50kg*
Height under hook:	2150mm
Reach:	2500mm
Weight:	from 60kg*
Height under hook:	2370mm
Reach:	3000mm
Weight:	from 65kg*
Height under hook:	2600mm
Reach:	3500mm
Weight:	from 75kg*
Height under hook:	2820mm
Reach:	4000mm
Weight:	from 80kg*
Height under hook:	3040mm

Technical specifications

Socket depth in deck: 450mm
 Socket internal diameter GRP, aluminium, stainless steel: 155mm
 Manual winch with 5:1 purchase
 Bearings: plain polyester (optional roller bearing)
 Construction: advanced pre-preg carbon fibre

* Actual davit weight defined by selected specification. We reserve the right to alter technical specifications without prior notification.

Twin davit[™] Raked

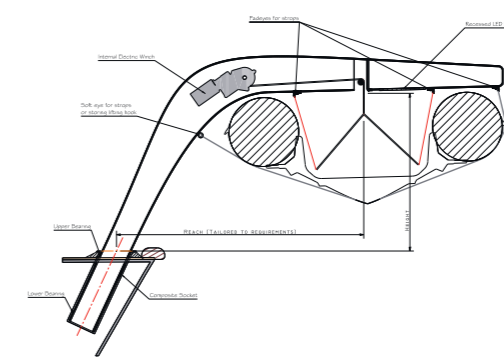

Twin davit[™] Slider

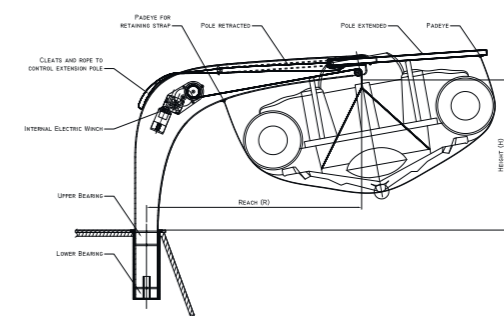

Twin davits have a safe working load (SWL) of 500kg

Reach:	1470mm
extending to:	2340mm
Weight:	45-50kg*
Height under hook:	900mm

Technical specifications

Winch: bespoke internal electric winch, 12 or 24 volt
 Socket depth in deck: 500mm
 Construction: advanced pre-preg carbon fibre

* Actual davit weight defined by selected specification. We reserve the right to alter technical specifications without prior notification.

Baby davit[™] Manual or optional electric winch

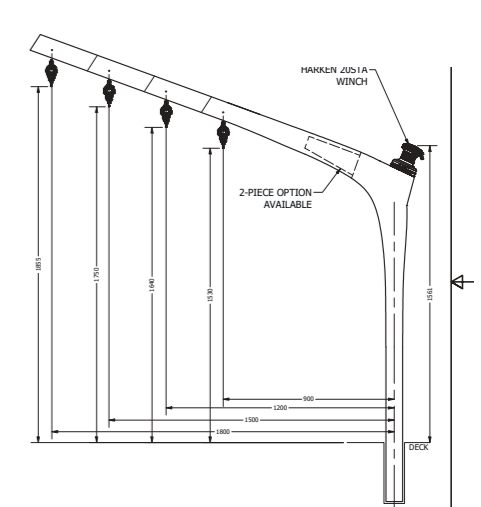

Baby davits have a safe working load (SWL) of 125kg, upgradeable to 250kg

Reach:	900mm
Weight:	11kg*
Height under hook:	1545mm
Reach:	1200mm
Weight:	12kg*
Height under hook:	1655mm
Reach:	1500mm
Weight:	13kg*
Height under hook:	1760mm
Reach:	1800mm
Weight:	16kg*
Height under hook:	1860mm

Technical specifications

Supplied with manual winch, 3:1 purchase
 Socket depth in deck: 310mm
 Socket internal diameter: 100mm
 Optional 12 or 24 volt electric winch
 Bearings: plain polyester
 Construction: advanced pre-preg carbon fibre



Standard davit

With manual or electric winch

The elegant, lightweight **atlas** standard davit perfectly compliments even the sleekest of superyachts. It makes light work of lifting jet skis, jet tenders, slides and rescue boats and has a safe working load (SWL) of 500kg.

Multiple deck sockets in stainless, GRP or aluminium allow for a single davit to be used in various locations around the vessel and then easily stowed away.

Choose from a spectrum of colours or carbon finish.

There are six standard sizes with reach ranging from 1500mm to 4000mm. Custom sizes and increased SWL are also available.

Twin davits

With electric winch

These twin yacht davits have been developed to suit the transoms of sailing vessels, bringing the elegant lines of the **atlas** range to the sailing yacht world. If you are looking for a solution to permanently lift and stow your dinghy or tender from the transom of your boat the **atlas** twin davit is the answer.

Our range includes raked twin davits and slider twin davits; both come with an internal electric winch as standard and have a safe working load of 500kg across the pair.

They come in a range of colours or carbon finish.

Baby davit

With manual or electric winch

With the same elegant lines and lightweight characteristics as our standard davits, the baby davit is the answer for smaller craft and docksides; perfect for lifting slides, seabobs and superyacht toys.

Multiple sockets in stainless, GRP or aluminium allow for a single davit to be used in a number of different locations. Choose from a spectrum of colours or carbon finish.

There are four standard sizes with a reach between 900mm and 1800mm, weighing from just 11kg and lifting 125kg as standard. They can also be upgraded to have a safe working load (SWL) of 250kg.

SUPERYACHTS



MOTOR BOATS



SAILING YACHTS



INDUSTRIAL



DOCK SIDE



CUSTOM



If you are looking for a custom composite solution for a marine or non-marine application we can help.

We often work with customers to produce custom carbon products to their specification.

Recent manufacturing projects include:

- lightweight components for renewable energy industry
- isolation screens for Royal Navy communications masts
- carbon fibre passerelles and landing craft
- carbon lifting beams



Atlas Carbon Products from **Jeremy Rogers Ltd**
Lymington Yacht Haven King's Saltern Road
Lymington Hampshire SO41 3QD United Kingdom.
T +44 (0)1590 646780 E info@atlascarbonproducts.com
atlascarbonproducts.com



JEREMY ROGERS
Boat Builders & Composite Specialists