



User Manual THERMICAM AI

R1.50-10, V1.02.P02





User Manual THERMICAM AI

The information contained in this document is subject to change without notice.

FLIR Intelligent Transportation Systems makes no warranty of any kind with regard to this material, including, but not limited to, the implied warranties of merchantability and fitness for a particular purpose.

FLIR Intelligent Transportation Systems shall not be liable for errors contained herein or for incidental or consequential damages in connection with the furnishing, performance, or use of this material.

No part of this document may be copied, reproduced, or translated to another language without the prior written consent of FLIR Intelligent Transportation Systems.

Copyright ©2024, FLIR Intelligent Transportation Systems - All rights reserved

FLIR Intelligent Transportation Systems
Hospitaalweg 1B
B-8510 Marke
Belgium
Tel: +32 (0)56 37.22.00
Fax: +32 (0)56 37.21.96
E-mail: flir@flir.com

EMC

This device complies with part 15 of the FCC Rules. Operation is subject to the following two conditions: (1) This device may not cause harmful interference, and (2) this device must accept any interference received, including interference that may cause undesired operation.

The user is cautioned that any changes or modifications not expressly approved by the party responsible for compliance could void the user's authority to operate the equipment.

Notwithstanding the fact this equipment is intended to be used in business, industrial and commercial environments, it has been tested and found to comply with the limits for a Class B digital device, pursuant to Part 15 of the FCC rules. These limits are designed to provide reasonable protection against harmful interference in a business, industrial and commercial environment as well as in a residential installation. This equipment generates, uses and can radiate radio frequency energy and, if not installed and used in accordance with the instructions, may cause harmful interference to radio communications.

Contact details of the legal representative are:

Mr. Chris Bainter
Vice-President Teledyne FLIR Strategic Business Development & Marketing
27700 SW Parkway Avenue
Wilsonville, OR 97070 USA
Phone: +1 800-419-4797
Mobile: +1 310-948-4279

Mr. Christopher Lewis
General Counsel, Teledyne Digital Imaging Americas
27700 SW Parkway Avenue
Wilsonville, OR 97070 USA
Phone: +1 503 498 3229
Mobile: +1 971 832 1196

 NOTE
<p>Product must be connected with following cables or electrical equivalent:</p> <ul style="list-style-type: none"> • Power cabling sensors : Installation cable 3 wires or equivalent only used for sensor connection • Ethernet cabling to sensor : UTP Cat5e or equivalent • Ethernet cabling to FLIR PoE interface : UTP Cat5e or equivalent <p>This device must be powered by a supply</p> <ul style="list-style-type: none"> • capable of sourcing <ul style="list-style-type: none"> ◦ for FLIR PoE interface : 25W ◦ for TI BPL3 : 80 to 120W, depending on cable size and cable length. • and a voltage range <ul style="list-style-type: none"> ◦ When powered by TI BPL3 : 12–60VDC ◦ When powered by FLIR PoE interface : 24–48VDC <p>See 7.4 <i>Typical use case power cable</i>, page 27.</p>

 CAUTION
<p>For BPL interfaced devices in installations where :</p> <ul style="list-style-type: none"> • Over-voltages are expected up to 2.5kV : Functional earth connection is recommended • Over-voltages are expected up to 4kV : Functional earth connection is mandatory <p>The functional earth connection should be</p> <ul style="list-style-type: none"> • connected to local (sensor nearby) earth connection • as short and rigid as possible

 NOTE
<p>WARNING: Any changes or modifications not expressly approved by the party responsible for compliance may disqualify the product for usage within the European Union.</p>

Export Controls

Products described herein may be subject to export regulations. For questions, please contact americassupport@teledyneflir.com (United States) or ordersupport@teledyneflir.com (other countries).

This document does not contain export-controlled information

Related hardware and firmware

Part number	Description	Hardware version	Firmware version
10-7730	ThermiCam AI 690	R1.50-10	V1.02.P02
10-7732	ThermiCam AI 645	R1.50-10	V1.02.P02
10-7734	ThermiCam AI 632	R1.50-10	V1.02.P02
10-7720	TI BPL3	R02.00	V1.00.P03
10-7320	FLIR PoE interface	R02.00	N/A
	Public API		V1.24

Normative compliance





Regulatory

	ThermiCam AI	TI BPL3	FLIR PoE interface
EU directives	<ul style="list-style-type: none"> • EMC 2014/30/EU • LVD 2014/35/EU • RED 2014/53/EU • RoHS 2011/65/EU 	<ul style="list-style-type: none"> • EMC 2014/30/EU • LVD 2014/35/EU • RoHS 2011/65/EU 	<ul style="list-style-type: none"> • EMC 2014/30/EU • LVD 2014/35/EU • RoHS 2011/65/EU
Product standards	<ul style="list-style-type: none"> • EN50556 	EN50556	<ul style="list-style-type: none"> • EN50556

Environmental

	ThermiCam AI	TI BPL3	FLIR PoE interface
Ambient condition	<ul style="list-style-type: none"> • Operating temperature: -40°C to +74°C <ul style="list-style-type: none"> ◦ Limited reliability & lifetime (@74°C) ◦ Recommended -40°C to +45°C • Storage temperature: -40°C to +85°C <ul style="list-style-type: none"> ◦ Affected lifetime (@85°C) ◦ Recommended -40°C to +40°C • Relative humidity: 0%-100% Condensing 	<ul style="list-style-type: none"> • Operating temperature: -40°C to +74°C <ul style="list-style-type: none"> ◦ Limited reliability & lifetime (@74°C) ◦ Recommended -40°C to +45°C • Storage temperature: -40°C to +74°C <ul style="list-style-type: none"> ◦ Affected lifetime (@74°C) ◦ Recommended -40°C to +40°C • Relative humidity: 0%-95% Non-Condensing 	<ul style="list-style-type: none"> • Operating temperature : -40°C to +74°C <ul style="list-style-type: none"> ◦ Lifetime 200000h : 12/24 @40°C ◦ Lifetime 100000h : 12/24 @50°C ◦ Lifetime 50000h : 12/24 @60°C • Storage temperature : -40°C to +85°C • Relative humidity : 5%-95%, 55°C (Non-Condensing)
Mechanical integrity	<ul style="list-style-type: none"> • EN50556: Environmental immunity <ul style="list-style-type: none"> ◦ EN60529 : Ingress protection IP68 ◦ EN62262 : Impact protection IK07 ◦ EN60068-2-1: Cold AE4 (-40°C) ◦ EN60068-2-2: Dry heat AB3 (60°C) ◦ EN60068-2-30: Damp heat AK2 ◦ EN60068-2-64: Vibration AM2/AL2 	<ul style="list-style-type: none"> • EN50556: Environmental immunity <ul style="list-style-type: none"> ◦ EN60529 : Ingress protection IP20 ◦ EN62262 : Impact protection IK07 ◦ EN60068-2-1: Cold AE4 (-40°C) ◦ EN60068-2-2: Dry heat AB3 (60°C) ◦ EN60068-2-30: Damp heat AK2 ◦ EN60068-2-64: Vibration AM2/AL2 	<ul style="list-style-type: none"> • EN50556: Environmental immunity <ul style="list-style-type: none"> ◦ EN60068-2-1: Cold AE4 (-40°C) ◦ EN60068-2-2 : Dry heat AB2 (55°C) ◦ EN60068-2-30 : Damp heat AK2 (40°C) ◦ EN60068-2-64 : Vibration AM2 / AL2
Electrical integrity	<ul style="list-style-type: none"> • EN50293 : EM Immunity <ul style="list-style-type: none"> ◦ EN61000-4-2 Air ESD : Level 3 ◦ EN61000-4-2 Contact ESD : Level 2 ◦ EN61000-4-3 Radiated : Level 3 ◦ EN61000-4-4 EFT Power : Level 2 ◦ EN61000-4-4 EFT Signal : Level 3 ◦ EN61000-4-5 Surges : Level 4 ◦ EN61000-4-6 Conducted : Level 3 ◦ EN61000-4-11 Dips : 20ms • EN55032 : EM Emission Class B 	<ul style="list-style-type: none"> • EN50293 : EM Immunity <ul style="list-style-type: none"> ◦ EN61000-4-2 Air ESD : Level 3 ◦ EN61000-4-2 Contact ESD : Level 2 ◦ EN61000-4-3 Radiated : Level 3 ◦ EN61000-4-4 EFT Power : Level 2 ◦ EN61000-4-4 EFT Signal : Level 3 ◦ EN61000-4-5 Surges : Level 4 ◦ EN61000-4-6 Conducted : Level 3 ◦ EN61000-4-11 Dips : 20ms • EN55032 : EM Emission Class B 	<ul style="list-style-type: none"> • EN50293 : EM Immunity <ul style="list-style-type: none"> ◦ EN61000-4-2 Air ESD : Level 3 (8kV) ◦ EN61000-4-2 Contact ESD : Level 2 (4kV) ◦ EN61000-4-3 Radiated : Level 3 ◦ EN61000-4-4 EFT Power : Level 2 ◦ EN61000-4-4 EFT Signal : Level 3 ◦ EN61000-4-5 Surges : Level 4 (L-PE: ±4kV) ◦ EN61000-4-6 Conducted : Level 3 (10Vrms) ◦ EN61000-4-11 Dips (NA) • EN55032 : EM Emission Class B (NO conducted emission)
Product safety	<ul style="list-style-type: none"> • EN62368-1 <ul style="list-style-type: none"> ◦ Equipment Class : CLASS II with functional EARTH ◦ Altitude : <2000m 	<ul style="list-style-type: none"> • EN62368-1 <ul style="list-style-type: none"> ◦ Equipment Class : CLASS II with functional EARTH ◦ Altitude : <2000m 	<ul style="list-style-type: none"> • EN62368-1 <ul style="list-style-type: none"> ◦ Equipment Class : Class I with protected Earth ◦ Altitude : <2000m

Product composition

	<table border="1"><tr><td data-bbox="754 432 786 477"></td><td data-bbox="826 439 882 461">NOTE</td></tr><tr><td colspan="2" data-bbox="746 488 1487 539"><p>This product is assembled in accordance with European regulations concerning environmentally-sensitive materials. See declaration of conformity.</p></td></tr></table>		NOTE	<p>This product is assembled in accordance with European regulations concerning environmentally-sensitive materials. See declaration of conformity.</p>	
	NOTE				
<p>This product is assembled in accordance with European regulations concerning environmentally-sensitive materials. See declaration of conformity.</p>					

Product usage

	CAUTION
<ul style="list-style-type: none">• FLIR Intelligent Transportation Systems accepts no liability for claims from third parties arising from improper use other than that stated in this manual.• Although considerable care has been taken to ensure a correct and suitably comprehensive description of all relevant product components, this manual may nonetheless contain errors and inaccuracies. We invite you to offer your suggestions and comments by e-mail via flir@flir.com. Your feedback will help us to further improve our documentation.• Do not use corrosive or abrasive means for product treatment. These may cause damage or degrade product performance and lifetime.• The operating voltage range of the device is 12-60VDC. There is no upper/lower tolerance allowed on these values for normal operation.	

Product disposal





	<table border="1"><tr><td data-bbox="754 1037 786 1081"></td><td data-bbox="826 1043 882 1066">NOTE</td></tr><tr><td colspan="2" data-bbox="746 1093 1487 1256"><p>The unit contains valuable materials which qualify for recycling. In the interest of protecting the natural environment, properly recycling the unit at the end of its service life is imperative.</p><p>It is the user's responsibility to dispose of the user's waste equipment by handing it over to a designated collection point for the recycling of waste electrical and electronic equipment.</p></td></tr></table>		NOTE	<p>The unit contains valuable materials which qualify for recycling. In the interest of protecting the natural environment, properly recycling the unit at the end of its service life is imperative.</p> <p>It is the user's responsibility to dispose of the user's waste equipment by handing it over to a designated collection point for the recycling of waste electrical and electronic equipment.</p>	
	NOTE				
<p>The unit contains valuable materials which qualify for recycling. In the interest of protecting the natural environment, properly recycling the unit at the end of its service life is imperative.</p> <p>It is the user's responsibility to dispose of the user's waste equipment by handing it over to a designated collection point for the recycling of waste electrical and electronic equipment.</p>					

Table of contents

1	Before you start: safety measures	1
1.1	General safety measures	1
1.2	Safety measures specific to TI BPL3	2
1.3	Safety measures specific to FLIR PoE interface	3
2	General product description	5
3	Architecture of a ThermiCam AI system, connected as BPL	6
3.1	Overview of a ThermiCam AI BPL (Broadband over Power Line) system	6
3.2	1 to 4 ThermiCam AI devices + TI BPL3 interface @ 24V DC	6
3.3	1 to 4 ThermiCam AI devices + max. 4 TI BPL3 interface @ 24V DC	7
4	Architecture of a ThermiCam AI system, connected as PoE	8
4.1	Overview of a ThermiCam AI PoE (Power over Ethernet) system	8
4.2	ThermiCam AI + FLIR PoE interface (External PSU + ETH to PoE)	8
5	System component	10
5.1	Components overview	10
5.2	The ThermiCam AI device	10
5.2.1	Available lens types	10
5.2.2	ThermiCam AI parts	10
5.2.3	LED indicator code	11
5.2.4	Maximum dimensions	11
5.3	The mounting accessories	12
5.4	Cable connector	12
5.5	TI BPL3 interface	14
5.6	FLIR PoE interface	16
5.6.1	Parts	16
5.6.2	Pin Assignment and Connections	17
6	Installation guidelines	20
6.1	FLIR Raven Tool	20
6.2	Selecting the right lens	20
6.3	Detection range chart	21
6.4	Defining installation height, position and orientation for minimal occlusion	21
6.5	Relation between detection area, lens type, installation height and position	22
6.6	Installation topology (only for BPL installation)	23
7	Installation procedure	24
7.1	Overview of the installation procedure	24
7.2	Installation tools required but not included with ThermiCam AI	24
7.3	Power Requirements for TI BPL3 (to sensors)	25
7.4	Typical use case power cable	27
7.4.1	BPL	27
7.4.2	PoE	27
7.5	BPL installation	28
7.5.1	Mounting the ThermiCam AI devices on a stable pole	28
7.5.2	Connecting the connector to the cable	29
7.5.3	Mounting the connector with cable on the device	30
7.5.4	Connecting ThermiCam AI to TI BPL3 and the controller	31
7.5.5	Fixing the antenna and optimizing the position of the ThermiCam AI devices	33
7.6	PoE mode A installation	33

Table of contents

7.6.1	Mounting the ThermiCam AI devices on a stable pole.....	33
7.6.2	Connecting the connector to the cable	34
7.6.3	Mounting the connector with cable on the device.....	35
7.6.4	Connecting ThermiCam AI to FLIR PoE interface and the controller	35
7.6.5	Fixing the antenna and optimizing the position of the ThermiCam AI devices	38
8	Connecting to ThermiCam AI	39
8.1	Wireless over Wi-Fi	39
8.2	Connecting to ThermiCam AI with known IP address	39
8.3	Connecting to ThermiCam AI with IP address unknown	39
9	About the web interface	41
9.1	Supported web browsers.....	41
9.2	Layout.....	41
10	TI BPL3 web interface	42
10.1	Navigation pane	42
10.2	Live View	43
10.3	Outputs	44
10.4	Error outputs.....	44
10.5	Network.....	45
10.5.1	Refreshing connected devices	45
10.5.2	Power toggling connected devices	45
10.5.3	Updating the BPL channel.....	45
10.5.4	Adapting the port numbers of the connected devices	46
10.6	Administration.....	46
10.6.1	General.....	46
10.6.2	Firmware.....	46
10.6.3	Users	47
10.6.4	Technical event log	47
10.6.5	System logs	47
10.6.6	Product security.....	47
11	ThermiCam AI web interface	48
11.1	Navigation pane	48
12	General settings.....	49
12.1	Adapting the general settings	49
12.2	Adapting the language of the user interface	49
12.3	Adapting the temperature threshold	49
12.4	Setting the GPS position of the device	49
12.5	Adapting the time settings.....	50
12.6	Importing and exporting configurations and offline networks.	50
12.7	Viewing general information about the device.....	51
13	Network settings	52
13.1	Adapting the IP settings.....	52
13.2	Adapting the Wi-Fi settings	52
13.3	Specifying the host for SNMP traps.....	53
13.4	Connecting to the Acylica cloud and enabling Wi-Fi Scanning for travel time calculation	53
13.5	Testing the network	53
14	User Management	54
14.1	User roles	54
14.2	Adding a new user	54
14.3	Changing the user settings.....	54
14.4	Removing a user.....	54

Table of contents

15	Licensing	55
15.1	Installing licenses.....	55
16	Calibration	56
16.1	Calibrating the device	56
16.2	Verifying the accuracy of calibration	56
17	Adapting the Region Of Interest (ROI) of the thermal core for more contrast	59
17.1	When to adapt the ROI of the thermal core	59
17.2	Adapting the ROI of the thermal core.....	59
17.3	Displaying the ROI as overlay in the camera image.....	59
18	Setting up AI detection	60
18.1	How to use AI Detection	60
18.2	Setting up AI detection	60
19	AI detection zones	61
19.1	How to use AI detection zones	61
19.2	Attributes of AI detection zones.....	61
19.3	Adding AI detection zones	61
19.4	Duplicating AI detection zones.....	62
19.5	Isolating AI detection zones.....	62
19.6	Deleting AI detection zones.....	62
19.7	Defining the zone name and characteristics	62
19.8	Switching to the minimal user interface	62
20	Trajectories	64
20.1	How to use trajectories.....	64
20.2	Adding trajectories	64
20.3	Removing trajectories	64
21	Applications	65
21.1	Adding applications.....	65
21.1.1	Event settings.....	65
21.1.2	Filter criteria.....	68
21.2	Duplicating applications	69
21.3	Removing applications.....	69
22	Linking detection zones and trajectories to an application	70
23	Tracking road users	71
24	Traffic data collection	72
24.1	About traffic data	72
24.2	About traffic data zones.....	72
24.3	Adding traffic data zones	73
24.4	Isolating a traffic data zone.....	73
24.5	Deleting traffic data zones.....	73
24.6	Defining zone properties and characteristics	74
24.7	Switching to the minimal user interface	74
24.8	Changing the default data integration settings	74
24.9	Counting road users	75
24.10	Setting up the detection of overspeed.....	75
24.11	Enabling individual data collection	75
24.12	Disabling integrated data collection.....	75
25	Flow monitoring	76
25.1	About flow monitoring	76
25.2	About flow data	76
25.3	Enabling flow monitoring	77
25.4	Changing the default flow data settings.....	77
25.5	Changing the thresholds for flow monitoring.....	77

Table of contents

25.6	Changing the event time on and time off	77
25.7	Setting the flow monitoring outputs	77
26	Masking zones	78
26.1	About masking zones	78
26.2	Adding masking zones	78
26.3	Duplicating masking zones	78
26.4	Isolating a masking zone	78
26.5	Deleting masking zones	79
27	Detection outputs	80
27.1	About the outputs	80
27.2	Normal status of the detection outputs	80
27.3	About the logical relation	80
27.4	About the pulse events (off) time for counting	80
27.5	Testing the outputs manually	81
27.6	Configuring the detection outputs	81
28	Displaying settings for overlay	82
28.1	Overriding the default settings for RYG phases	82
28.2	Configuring the overlay	82
29	Recall	84
29.1	About time-out	84
29.2	Adapting the recall settings	84
29.3	Assigning thermal quality recall or detection quality recall to one or multiple outputs	84
30	Working with existing configurations and offline networks	85
30.1	About sending configurations	85
30.2	About offline networks	85
30.3	Exporting and importing a configuration or offline network	85
30.4	Restarting ThermiCam AI with the current or factory default configuration	85
31	Communication protocol: public API	86
31.1	About the Public API manual	86
31.2	Accessing the Public API manual	86
31.3	General functionality	86
31.4	Supported events types	86
31.5	Supported data types	87
32	Data transfer from ThermiCam AI to a PC using Traficon Data Tool	88
32.1	Data storage on ThermiCam AI	88
32.2	About Traficon Data Tool	88
32.3	Installing and starting Traficon Data Tool	88
32.4	Main window	88
32.5	Working with Traficon Data Tool	89
32.5.1	Defining the download settings	89
32.5.2	Finding the devices	89
32.5.3	Defining where to store the downloaded files	90
32.5.4	Selecting the devices	90
32.5.5	Downloading the data and events history	90
32.5.6	Downloading data and events in a particular time frame	90
32.5.7	Monitoring data and events in real time	90
32.5.8	Converting a .csv file to an .xls file via MS Excel	91
33	Streaming video	92
33.1	About streaming video	92
33.2	Changing the default video settings	92









Table of contents

33.3	Viewing streaming video via the web interface.....	92
33.4	Viewing and recording streaming video via VLC media player.....	93
33.4.1	About VLC media player	93
33.4.2	To view streaming video via VLC media player	93
33.4.3	To record streaming video via VLC media player	94
33.5	Viewing streaming video via ONVIF Profile S	95
34	Product security.....	96
34.1	About product security	96
34.2	Enabling or disabling services	96
34.3	User authentication	97
34.4	Physical access.....	97
34.5	Certificates.....	97
34.5.1	Self-signed vs. CA-signed certificates.....	97
34.5.2	Implementing certificates for ThermiCam AI	98
34.6	EAPOL.....	98
34.7	Exporting the physical access log	99
34.8	Exporting the user log	99
35	Maintenance and troubleshooting	100
35.1	Periodic maintenance	100
35.2	Firmware upgrade of ThermiCam AI.....	100
35.3	Technical Event log	100
35.4	System log	101
35.5	Replacing a ThermiCam AI device.....	101
35.5.1	To uninstall the broken ThermiCam AI device	101
35.5.2	To install the replacement ThermiCam AI device	101
35.5.3	To make the replacement device operational	102
35.6	Replacing a TI BPL3 device (BPL only).....	102
35.6.1	To uninstall the broken TI BPL3 device.....	102
35.6.2	To install the replacement TI BPL3 device.....	103
35.6.3	To make the replacement device operational	103
35.7	Replacing the fuses of a TI BPL3 EURO	103
36	Appendix: ThermiCam AI dimensions	106
37	TI BPL3 Cabling — extended.....	108
38	Annex — About FLIR ITS's AI process	113
38.1	Compliance	113
38.2	AI classification reference icons and images	113







Before you start: safety measures

1.1 General safety measures



To avoid bodily harm or product damage, take care of the following safety measures:

 WARNING
If there is any doubt regarding the safety of the equipment, do not put it into operation.
 WARNING
Do not disassemble the product nor remove screws or covers to prevent injury or electric shock. Product should be serviced by skilled personnel only.
 WARNING
Handle the product with care, avoid bumping and shaking. The product can be damaged by improper handling or storage causing safety hazards.
 WARNING
Using the product within operating temperature range may cause the surface to become extremely hot or cold. Handle with proper precaution.
 WARNING
This product should only be used on altitude below 2000 m or 6560 ft with respect to sea level.
 WARNING
This product is to be installed and maintained by skilled persons only.
 WARNING
BPL installation cables shall have sufficient electrical insulation withstanding voltages of at least 2500V _{peak} unless external measures ensure lower maximum transients.
 WARNING
Ethernet installation cables shall have sufficient electrical insulation appropriate to the installation withstanding voltages of at least 1500V _{peak} unless external measures ensure lower maximum transients.
 WARNING
In case of BPL interfacing, the wire bridges in the sensor connector must be used to ensure safety, performance and robustness.





Before you start: safety measures

 WARNING
<p>System AC or DC supply shall :</p> <ul style="list-style-type: none"> • Be suitable for expected environmental conditions such as Temperature, Humidity and Pollution degree • Have reliable means for protection against electric shock consisting of <ul style="list-style-type: none"> ◦ Basic Insulation to mains withstanding 2500Vpeak continuously with secondary circuit reliably connected to Protective Earth OR ◦ Reinforced insulation to nominal mains permanently withstanding 4000Vpeak continuously with no further requirements in the sense of EN/IEC61140 <p>AND shall be derived from :</p> <ul style="list-style-type: none"> • AC Mains not exceeding 250Vrms Overvoltage category II OR • AC Mains not exceeding 150Vrms Overvoltage category III OR • AC Mains not exceeding 50Vrms Overvoltage category IV OR <p>Otherwise a dedicated system SELV power supply shall be used that</p> <ul style="list-style-type: none"> • Is suitable for the primary connected mains power distribution system AND • Is protected for expected transients of 1500Vpeak secondary <ul style="list-style-type: none"> ◦ By means of sufficient insulation to other parts, circuits and live parts OR ◦ By means of adequate transient suppressors to earth
 WARNING
Dry outputs must be connected using paired conductors
 WARNING
Installation cables and/or wires exposed to daylight shall be UV resistant.
 WARNING
Installation cables and / or wires shall be protected and/or mechanically appropriate to the environment of installation to ensure safety.
 WARNING
This equipment is not suitable for use in locations where children are likely to be present.
 WARNING
An all pole mains switch appropriate to the installation shall be incorporated external to the equipment.
 NOTE
This product is ingress protected to level IP67.







1.2 Safety measures specific to TI BPL3

 WARNING
This product is to be used in a controlled environment where no condensing conditions occur.
 WARNING
Double pole fuse is used - After fuse operation, parts of the equipment may remain energized representing a hazard during service.
 WARNING
Dry contacts installation cables shall have sufficient electrical insulation appropriate to the installation environment withstanding voltages of at least 1500Vpeak.







Before you start: safety measures

	WARNING
Sensor installation cables and / or wires with current capacity less than 4 Ampere effective shall be provided with double pole very fast acting (FF) external over-current protection device appropriate to wiring and power supply used.	
	WARNING
Interface power supplying cable shall have a wire section of 1,5mm ² or AWG16 and a length of maximum 2 meter.	
	WARNING
Replacement of over-current protecting fuse(s) must be carried out with a suitable type:	
<ul style="list-style-type: none"> • Voltage range: 250VAC • Current rating: 4A • Breaking current : 1000A • Time delay : FF • Approved fuses <ul style="list-style-type: none"> ◦ Littelfuse 2301400043 / 2301400002 / 2301400000 ◦ Shurter 0034.0907 ◦ SIBA 70 007 40.4 / 7000140.4 	
	WARNING
The equipment is to be installed in climate conditions preventing condensation or an outdoor enclosure rated IP54 or better.	

1.3 Safety measures specific to FLIR PoE interface

	NOTE
This is not an 802.3af compliant device, there is no negotiation towards the PoE powered devices. As such, the power is always delivered over the Ethernet cable regardless of the device it is going to.	
	WARNING
From a safety point of view, this is a Class I device. It is connected to equipment installed outdoor. In order to protect other equipment and to avoid electrical shock from hazardous ESD, the device must be grounded properly. The ground pin on the power terminal block must be earthed at all times. This wire must have a min. core cross section of 0.5 mm ² (22 AWG). Consult national building wire requirements for the exact size.	
	WARNING
The connection cables for connecting of the power supply unit must have a core cross section of 1mm ² (18 AWG)	
	WARNING
The equipment must be powered with a safety extra low voltage (SELV) supply in de sense of IEC61140 suitable for the expected environmental conditions.	
	WARNING
Output contacts will only be connected to SELV circuits	
	WARNING
Ethernet interface shall only be connected to a network with transient protection limiting expected over-voltages below 75V _{peak} - Cabling to protection must be shorter than 10m	

Before you start: safety measures

 WARNING
System DC supply : A dedicated system SELV power supply shall be used that <ul style="list-style-type: none">• is suitable for the used mains power distribution system AND• Is sufficiently insulated from other parts and circuits and live parts and circuitry are not accessible (According to EN62368-1 Annex V) OR• Is equipped with protection means for transient of 1500Vpeak from external circuits on its secondary circuit
 WARNING
The cabinet in which the PoE interface is installed, shall act as a fire enclosure and is therefore made of: non-combustible material (e.g. metal, glass, ceramic) OR V-1 class material
 WARNING
All components of the PoE interface are non-combustable, but to reduce the likelihood of sustaining flaming or spread of fire in the cabinet, make sure there is a clearance of 50mm above and below the unit and a lateral distance of 20mm to other units to guarantee sufficient separation between combustible materials
 WARNING
This product has an internal overcurrent protection with a 2-pole Fast acting fuse of 1,6A
 WARNING
The external power supply should be equipped with an appropriate disconnect device (e.g. miniature circuit breaker). The disconnection unit and the electrical outlet for the power supply unit must be freely accessible at all times
 WARNING
The external power supply must have a built-in overcurrent protection of max 10A
 WARNING
The equipment is to be installed in climate conditions preventing condensation or an outdoor enclosure rated IP54 or better

General product description

ThermiCam AI is an intelligent thermal imaging sensor for traffic monitoring in complex urban environments..

Capable of tracking multiple traffic objects in any lighting condition, ThermiCam AI effectively controls intersections, helps protect vulnerable road users and gathers detailed traffic data for better city planning decisions.

Architecture of a ThermiCam AI system, connected as BPL

3.1 Overview of a ThermiCam AI BPL (Broadband over Power Line) system

In a BPL (Broadband over Power Line) installation, the TI BPL3 interface is placed in the controller cabinet and serves as the interface between ThermiCam AI and the traffic light controller. Depending on cable length and PSU voltage, maximum 4 ThermiCam AI units can be connected to a single TI BPL3. Up to 4 TI BPL3 units can be used in a cabinet. All interfaces require a different key and a different IP address. The cameras have the same IP-address of the corresponding interface, but unique ports will allow all cameras to be unique and separately accessible.

The PC is connected to the ThermiCam AI devices via TI BPL3. This connection, on site or remote, allows you to set up the system or view streaming video from the ThermiCam AI.

3.2 1 to 4 ThermiCam AI devices + TI BPL3 interface @ 24V DC

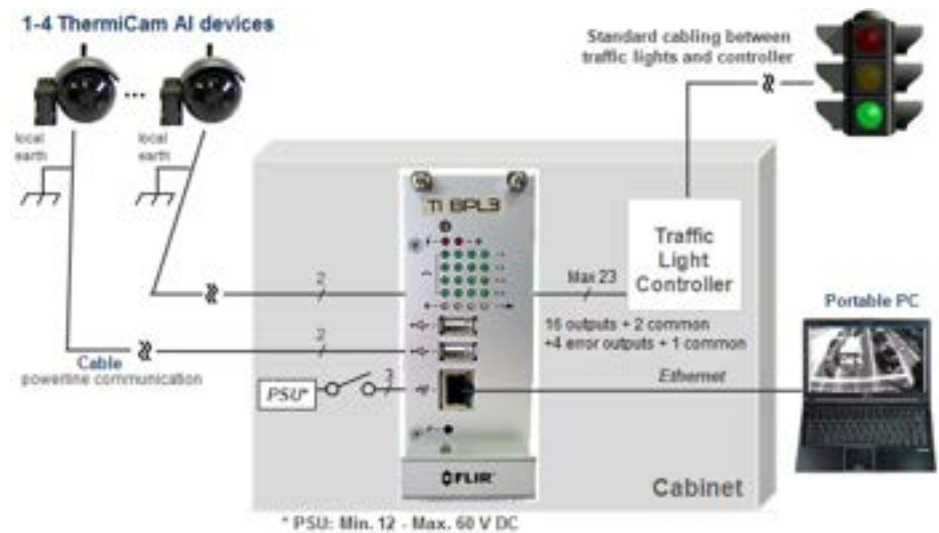

Figure 3.1 System architecture: BPL installation of 1 to 4 ThermiCam AI devices with TI BPL3 interface

NOTE
1. The cabinet shall only be accessed by skilled persons.
2. Number of sensors depends on cable length & section and power rating of power supply
3. The voltage range of the PSU should be compatible with the voltage range of the connected sensors.
4. Applied voltage is not allowed to exceed specified maximum of connected sensors.
5. Power rating depends on number of sensors and cable length & section (see 7.4 <i>Typical use case power cable</i> , page 27)

3.3 1 to 4 ThermiCam AI devices + max. 4 TI BPL3 interface @ 24V DC

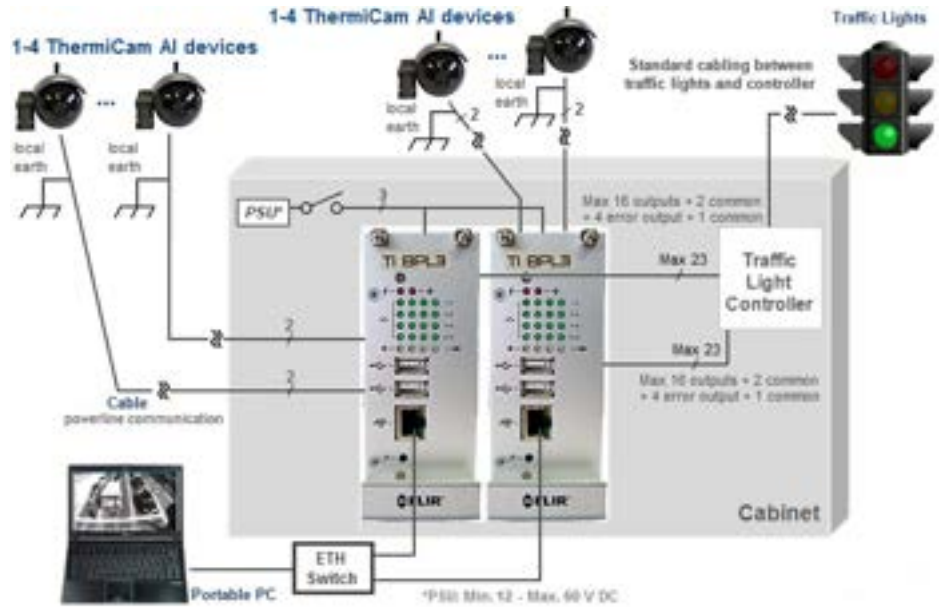

Figure 3.2 System architecture: BPL installation of 1 to 4 ThermiCam AI devices with maximum 4 TI BPL3 interfaces



NOTE

1. The cabinet shall only be accessed by skilled persons.
2. Number of sensors depends on cable length & section and power rating of power supply
3. The voltage range of the PSU should be compatible with the voltage range of the connected sensors.
4. Applied voltage is not allowed to exceed specified maximum of connected sensors.
5. Power rating depends on number of sensors and cable length & section (see 7.4 *Typical use case power cable*, page 27)

Architecture of a ThermiCam AI system, connected as PoE

4.1 Overview of a ThermiCam AI PoE (Power over Ethernet) system

In a PoE installation, the FLIR PoE interface is placed in the controller cabinet and serves as the interface between ThermiCam AI and the controller. Maximum 1 ThermiCam AI unit can be connected to a single FLIR PoE interface via RJ45 port or via the terminal block. Multiple FLIR PoE interface units can be used in a cabinet.

The PC is connected to the ThermiCam AI via the FLIR PoE interface. This connection, on site or remote, allows you to set up the system or view streaming video from the ThermiCam AI.

4.2 ThermiCam AI + FLIR PoE interface (External PSU + ETH to PoE)

In this system architecture, ThermiCam AI is powered by an external PSU, either via a DC jack or terminal block of the FLIR PoE interface. Multiple FLIR PoE interfaces are connected to the PC using an ETH switch.

Connect PE terminal connection to the PE connection of the cabinet. PE connection of sensor should always be connected to the pole.

For more information on the output pinning, see Figure 5.5 *PCB layout RJ45 Data Out & Terminal Block*, page 18.

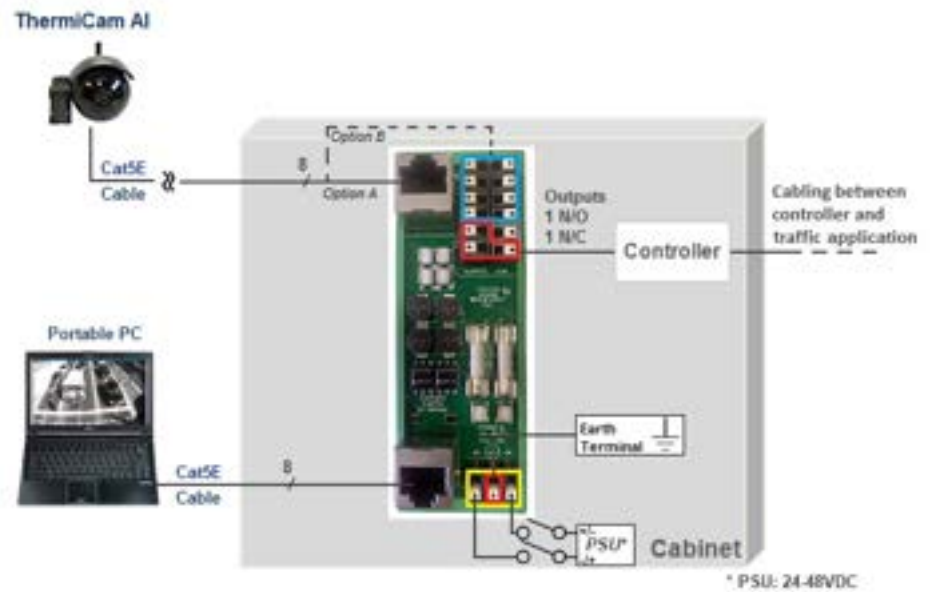

Figure 4.1 ThermiCam AI with external PSU and FLIR PoE interface



NOTE

- The cabinet shall only be accessed by skilled persons.
- This is not an 802.3af compliant device, there is no negotiation towards the PoE powered devices. As such, the power is always delivered over the Ethernet cable regardless of the device it is going to.

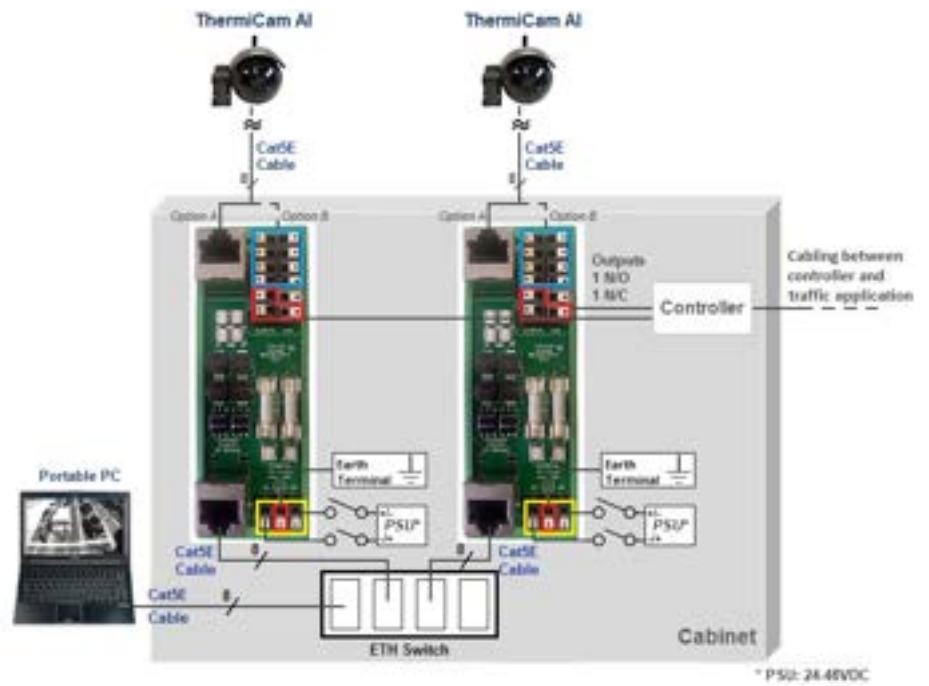

Figure 4.2 Multiple ThermiCam AI units with external PSU and FLIR PoE interface



NOTE

- The cabinet shall only be accessed by skilled persons.
- This is not an 802.3af compliant device, there is no negotiation towards the PoE powered devices. As such, the power is always delivered over the Ethernet cable regardless of the device it is going to.

5.1 Components overview

- ThermiCam AI
- Mounting accessories
- Connector
- TI BPL3
- FLIR PoE interface



WARNING

Product supporting devices such as Power supplies, Ethernet switches and the like, should be suitable for the environment in which they are used. Using recommended supporting devices are no guarantee for a safe and reliable installation. Always follow the manufacturer's instructions.

5.2 The ThermiCam AI device

5.2.1 Available lens types

The table below lists the available products, based on the lens type.

Product Reference Number	ThermiCam AI lens
10-7730	ThermiCam AI 690
10-7732	ThermiCam AI 645
10-7734	ThermiCam AI 632

For more information on lens selection, see 6.2 *Selecting the right lens*, page 20.

5.2.2 ThermiCam AI parts

The ThermiCam AI device consists of the following parts:



Figure 5.1 Front and back view of ThermiCam AI

- A. Mounting bracket for the sensor
- B. Wi-Fi antenna
- C. Sunshield
- D. Lens
- E. LED
- F. Connector (to the TI BPL3 interface)









WARNING

Product should never be opened, no serviceable parts inside. Opening device will jeopardize the product integrity and void warranty.

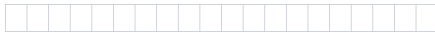
 CAUTION
If the sensor is exposed to direct sunlight the sunshield must be used to ensure minimum product lifetime.

5.2.3 LED indicator code

The table below illustrates the LED indicator code.

LED	Indication
Off 	No power or hardware failure
Quick flashing red 	ThermiCam AI is starting up or rebooting
Slow blinking red 	OS started
Continuous green 	ThermiCam AI has started up or no configuration
Continuous red 	Detection
Single flashing red (with a pause after each flash) 	Failsafe mode - detection quality recall
Double flashing red (with a pause after each sequence of two) 	Failsafe mode - thermal quality recall, image quality or bad video
Triple flashing red (with a pause after each sequence of three) 	ThermiCam AI is learning (startup recall) or no outputs assigned
Slow alternating red/green 	Firmware upload using OS or default config

5.2.4 Maximum dimensions

Height	Housing with connector	160 mm
	Housing with bracket (mast-mount in longest position)	460 mm
Depth	Housing with connector	160 mm
	Housing with bracket	160 mm
Width	Housing	160 mm
	Housing with bracket	190 mm
Mass	Housing with sunshield, connector and Wi-Fi antenna	1096 g

5.3 The mounting accessories

There are 2 mounting brackets:

- Mounting bracket for the ThermiCam AI device (see Figure 5.1 *Front and back view of ThermiCam AI*, page 10.)
- Mounting bracket to the pole as described below.

The tube connects both brackets.

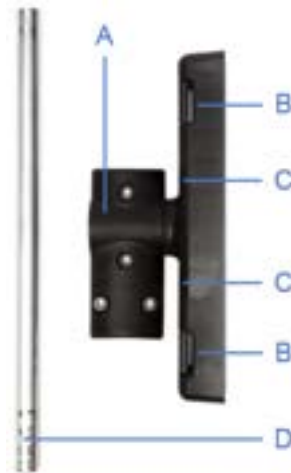

- A. Mounting bracket to the pole
- B. Holes to put the stainless steel retaining straps through
- C. Holes to mount ThermiCam AI using stainless steel bolts (M8)
The screws to tighten after ThermiCam AI has been positioned are located on the backside of the mounting bracket.
- D. Tube

Figure 5.2 The mounting accessories

5.4 Cable connector

Part number CNCIR008F1



- A. Cable gland nut
- B. Cable holder with cable gland nut (A)
- C. 8 pole connector
- D. Fixation ring

The pins of the generic cable connector should be connected as follows:

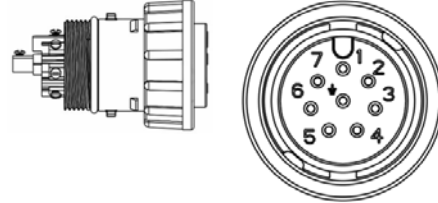





Function	Pin	BPL	PoE Mode A
			
Power & Communication	1	BPLA Use copper bridges (mounted by default)	Tx+ Remove copper bridges
	2		TX- Remove copper bridges
	3	BPLB Use copper bridges (mounted by default)	RX+ Remove copper bridges
	4		RX- Remove copper bridges
Outputs	5	NC	NC
	6	NO	NO
	7	COM	COM
Protection		Earth — Connect firmly to local earth	Do not connect

Table 5.1 Interface bandwidth and detection outputs specifications on generic connector

PoE interface	Maximum bandwidth: >90Mbps
Dry outputs	Maximum voltage <ul style="list-style-type: none"> Absolute maximum : 60Vpeak Maximum current <ul style="list-style-type: none"> Absolute maximum : 50mA RMS (Polyfuse) Maximum resistance: 35Ω

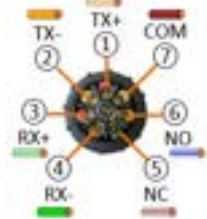
5.5 TI BPL3 interface

	NOTE
ThermiCam AI is not compatible with TI x-stream (10-6085) and TI BPL2 (10-7085) !	
	WARNING
<ul style="list-style-type: none"> • This interface should only be used in combination with its accompanying backplane (EU). • This interface should be switched off from power supply externally before removal. 	

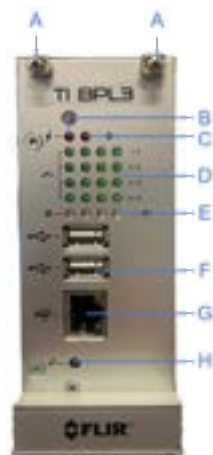

- A. Premounted screws M2.5x11
- B. Power LED
- C. Error LED
 - **On + status LED red** : Error in the connected ThermiCam AI (e.g. no communications or no power)
 - **On + Status LEDs green** : Error in the interface (e.g. BPL no power, processor down)
- D. LEDs for the presence detection outputs 1 to 16
- E. Status LED
 - **Green** : ThermiCam AI connected and operational
 - **Red + error LED off** : No ThermiCam AI connected
 - **Red + error LED on** : Error in connected ThermiCam AI
- F. 2 USB ports - not used (Service Only)
- G. LAN connector
 - **Green LED On (off)**: connection to the network (no connection)
 - **Orange LED On**: LAN data transfer rate 100 Mbps
- H. Restart button

Figure 5.3 The TI BPL3 interface — front panel

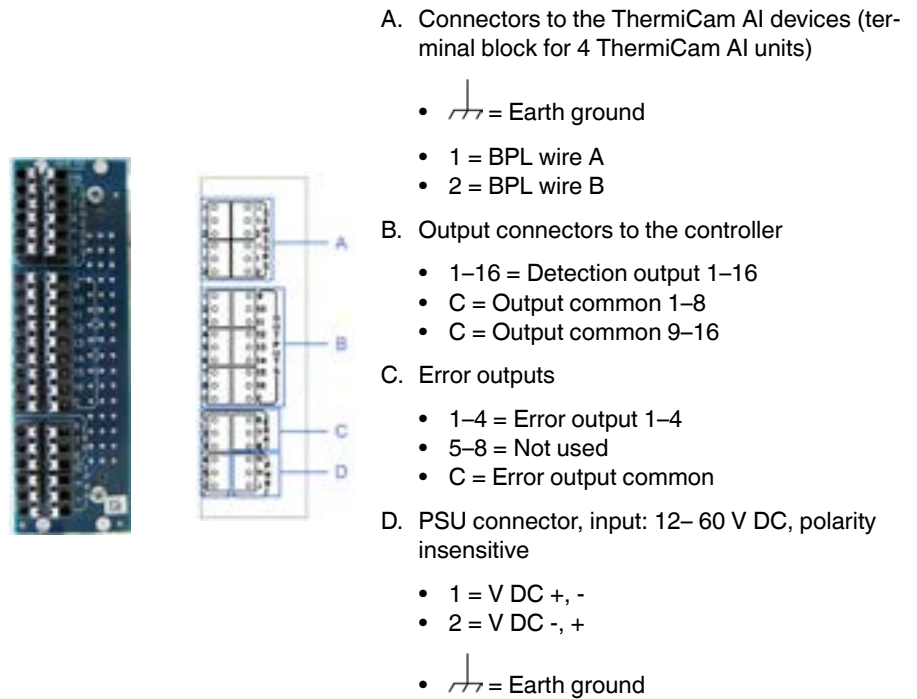

Figure 5.4 The TI BPL3 interface — backplane

 NOTE
The small screws to attach the back PCB to the box are in a small plastic bag together with the DIN-rail brackets.

Table 5.2 Maximum dimensions of TI BPL3

	TI BPL3 EURO
Height	128 mm
Depth	210 mm
Width	50 mm
Weight	610 g

5.6 FLIR PoE interface

5.6.1 Parts

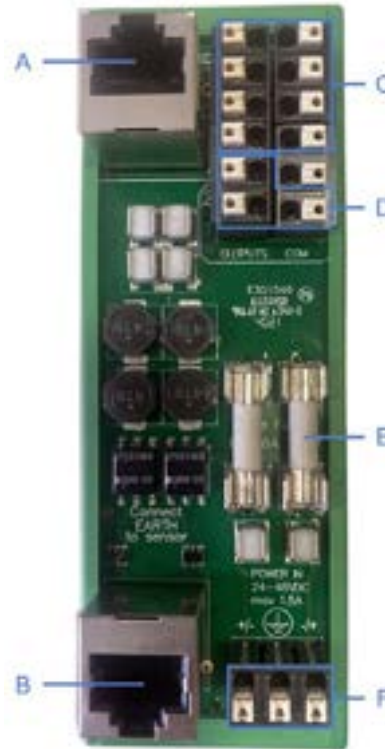

- A. RJ 45 port for PoE connection to sensor (PoE Out) — See 5.6.2.3
 B. RJ45 port for LAN connection to PC/laptop (Data In) — See 5.6.2.1.
 C. 8–slot terminal block for PoE connection to sensor (option B) — See 5.6.2.4

Left	Right
Orange/white	Orange
Green/white	Green
Blue/white	Blue
Brown/white	Brown









- D. Detection outputs from sensor

Left	Right
Output 2 (Normal Open)	Not connected
Output 1 (Normal Closed)	Common

- E. Fuses: 2 x FF 1.6A 250V
 F. 3–slot terminal block for external SELV power supply 24–48 VDC — See 5.6.2.2
- Left/Right: DC (no polarity)
 - Middle: PE (to be connected to earth)

5.6.2 Pin Assignment and Connections

5.6.2.1 RJ-45 Data In: 10/100BASE-T Ethernet (B in the image below)

Pin	Wire Color	Signal
1		Tx+
2		Tx-
3		Rx+
4		N/A
5		N/A
6		Rx-
7		N/A
8		N/A

5.6.2.2 DC Power Supply input Terminal Block (D in the image below)

Pin	DC
1	V +/-
2	Protective Earth terminal
3	V -/+

5.6.2.3 RJ-45 Data Out / PoE Mode A (A in the image below)

Table 5.3 10/100BASE-T Ethernet











Pin	Wire Color	Signal	Power Signal PoE Mode A (DC)
1		Tx+	V+
2		Tx-	V+
3		Rx+	V-
4	N/A	N/A	N/A
5	N/A	N/A	N/A
6		Rx-	V-
7	N/A	N/A	N/A
8	N/A	N/A	N/A

Table 5.4 FLIR Sensor Detector Outputs

Pin	Wire color	Signal
1		N/A
2		N/A
3		N/A
4		N/A
5		Sensor switch: NO (Normal Open)
6		N/A
7		Sensor switch: NC (Normal Closed)
8		Sensor switch: COM (Common)

5.6.2.4 Data Out / PoE Mode A Terminal Block (C in the image below)

Table 5.5 10/100BASE-T Ethernet

Con#	Pin#	Wire Color	Signal
CN7	Pin 3		TX+
CN7	Pin 2		RX+
CN7	Pin 1		N/A
CN6	Pin 3		N/A









Con#	Pin#	Wire Color	Signal
CN8	Pin 1		Tx-
CN8	Pin 2		Rx-
CN8	Pin 3		N/A
CN5	Pin 1		N/A

Table 5.6 Sensor switch outputs

Con#	Pin#	Wire Color	Signal
CN6	Pin 2		Output 2 (Normal Open)
CN6	Pin 1		Output 1 (Normal Closed)

Con#	Pin#	Wire Color	Signal
CN5	Pin 2		Not connected
CN5	Pin 3		Common

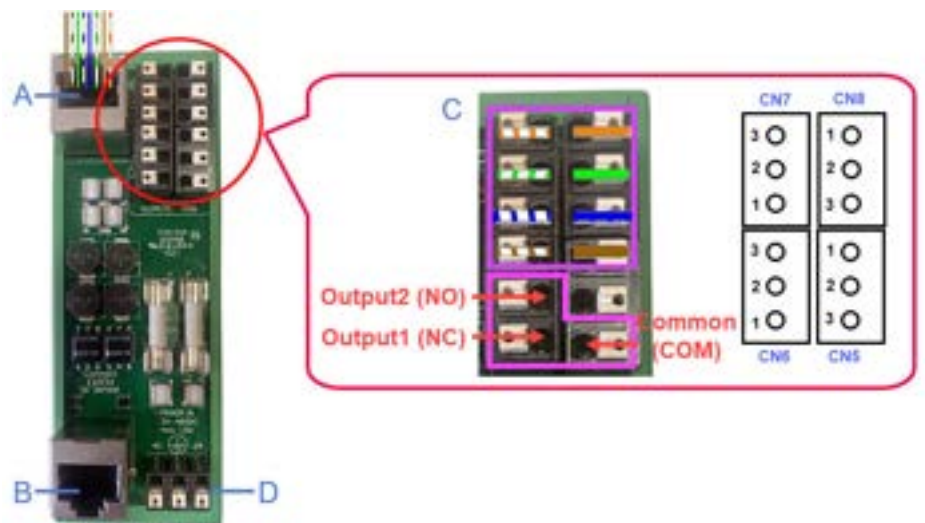

Figure 5.5 PCB layout RJ45 Data Out & Terminal Block

**NOTE**

- The terminal block holds the wires in their terminals with push-in contacts.
- It is highly recommended to use wire ferrules on the wire ends to make a reliable electrical connection.
- Cross section of the wire:
 - Minimum: AWG24 (0,34 mm²)
 - Maximum: AWG16 (1,5 mm²)
- Stripping length: 8 mm

6.1 FLIR Raven Tool





For easy and professional site planning, use the Raven tool for ITS camera simulation in an easy-to-use Google Maps layout. For more information and access, see <https://www.flir.com/security/raven-site-planning-tool>.

6.2 Selecting the right lens

The various types of ThermiCam AI devices allow you to focus on your region of interest for the following applications:

- Presence detection, e.g. green on demand, with ThermiCam AI installed at the stop bar.
- Traffic adaptive detection (count and/or zone occupancy measurement, e.g. for SCATS, SCOOT, ITACA, UTOPIA, ADIMOT) use presence or the position, speed and heading information (i.e. live track data over API).
- Traffic data collection.
- Detection of wrong way drivers.

Table 6.1 ThermiCam AI lens specifications VGA 640 x 480 resolution

Type	Focal distance	Angle of view		Example of the camera image	Detection distance
		Horizontal	Vertical		
690 (10-7730)	7,5 mm	90°	69°	25m  60m 	short range 0-25 m (0-85 ft) 5-60 m (16-200 ft)
645 (10-7732)	13 mm	45°	37°		medium range 10-100 m (33-330 ft)
632 (10-7734)	19 mm	32°	26°		long range 15-150 m (50-495 ft)

6.3 Detection range chart

NOTE

- The detection ranges in the following chart are indicative. Make sure to always check which lens type best suits your specific location and required application.
- The detection distances are for a single vehicle with no occlusion and no dense traffic in good clear weather conditions.
- The detection range chart gives an indication of the distance at which we can detect the presence of objects.
- The striped area does not guarantee that the detected object will be correctly identified.

TrafiSense / ThermiCam AI (VGA) Detection Range Chart @ 6m installation height with a clear line of sight

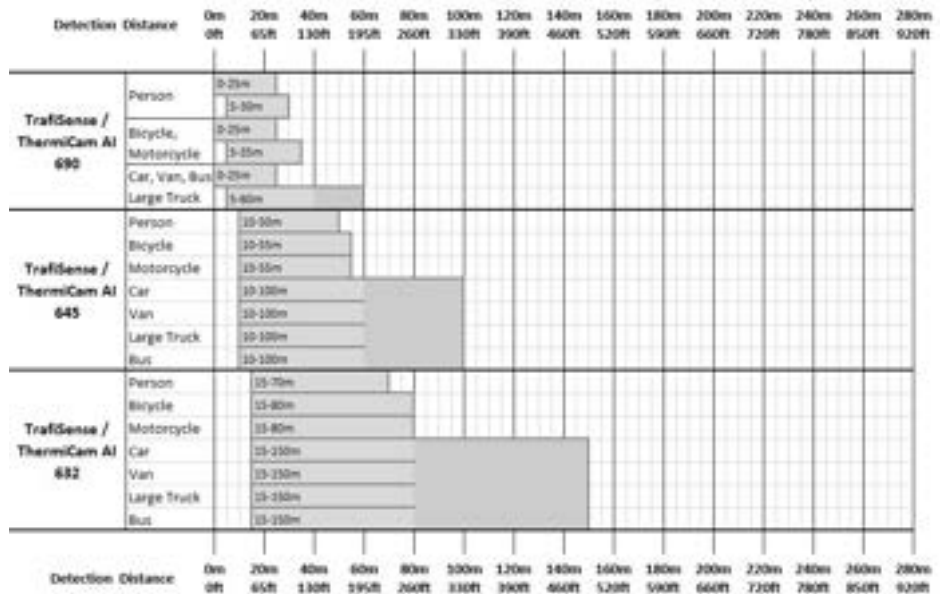

6.4 Defining installation height, position and orientation for minimal occlusion

The height and position of the camera are important factors for minimizing occlusion. Occlusion occurs when a vehicle blocks part of the camera’s field of view. Please contact FLIR Intelligent Transportation Systems for more information on how to minimise or avoid occlusion.

Keep the following in mind when installing the ThermiCam AI :

- Installation height
 - For presence detection and detection of wrong way drivers
Depending on the number of lanes to monitor and the position of ThermiCam AI towards the road, we recommend the following installation height:

Table 6.2 Installation height in function of the number of lanes to monitor and the position of ThermiCam AI

Lanes to monitor	Side-fired	Overhead	Installation height (to avoid occlusion)
1	x		≥ 3,5 m / 11,5 ft
1		x	≥ 5 m / 16,4 ft
2	x		≥ 8 m / 26,2 ft
2		x	≥ 5 m / 16,4 ft
3	x		≥ 12 m / 39,4 ft

Table 6.2 Installation height in function of the number of lanes to monitor and the position of ThermiCam AI (continued)

Lanes to monitor	Side-fired	Overhead	Installation height (to avoid occlusion)
3		x	≥ 7 m / 23,0 ft
4	x		≥ 12 m / 39,4 ft (To minimise occlusion)
4		x	≥ 8 m / 26,2 ft

- For traffic data collection
Mount the camera as high as possible. The minimum installation height is 6 m / 20 ft
- Position towards the road
 - In case of 1 lane, put the camera in a side-fired position next to the road (pan angle = 25°).
 - In case of 2 lanes, put the camera in overhead position in the middle of the 2 lanes.
 - In case of 3 lanes, put the camera in overhead position of the middle lane (pan angle 0° towards the middle lane).
 - In case of 4 lanes, put the camera in overhead position, in the middle between lane 2 and 3.



NOTE

For detection of wrong way drivers on multiple lanes, make sure to mount ThermiCam AI high enough to avoid occlusion.

- Device orientation
 - Position the camera so that 60-80% of the image is road and 40-20% is other (vegetation, buildings and a max of 10% sky).
 - For presence detection
Make sure you can define the presence detection zones in the central part of the camera image.
 - For bike detection
Detection area should be at the bottom part of the image. (max. tilt angle 45°, ideally 30°, max. pan angle 25°, ideally 0°, roll angle should be 0°).
 - For traffic data collection
Turn the device towards upcoming traffic.
 - For detection of wrong way drivers
Turn the device towards upcoming or receding traffic.

6.5 Relation between detection area, lens type, installation height and position

The detection area and the minimum and maximum detection distance are related to the installation height and the lens type of the device and its position towards the road. Position the presence detection zones within the detection area.

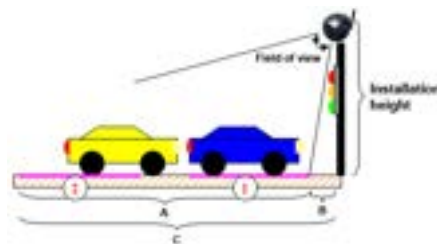

- A. Detection area
- B. Minimum detection distance
- C. Maximum detection distance
- 1. Presence detection zone 1
- 2. Presence detection zone 2

Figure 6.1 Detection area

6.6 Installation topology (only for BPL installation)

Connect the sensors to the interface in a star or bus topology or a combination of both.

- Star topology
Each ThermiCam AI is connected directly to the interface.
- Bus topology (also known as daisy chain)
All ThermiCam AI devices are connected in sequence. One sensor is connected to the interface.
- Combined star-bus topology
See below

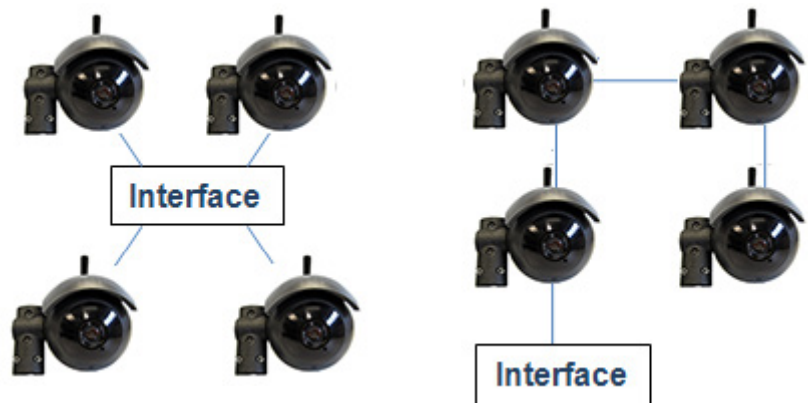

Figure 6.2 Star topology (left) and bus topology/daisy chain (right)

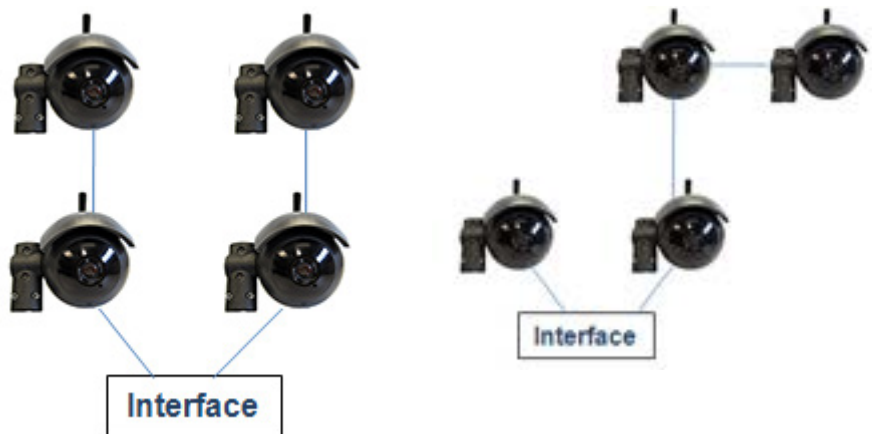

Figure 6.3 Combined star and bus topology

Installation procedure

7.1 Overview of the installation procedure

Installing a standard ThermiCam AI system consists of the following tasks:

- For BPL installation:
 1. *Mounting the ThermiCam AI devices on a stable pole*
 2. *Connecting the connector to the cable*
 3. *Mounting the connector with cable on the device*
 4. *Connecting ThermiCam AI to TI BPL3 and the controller*
 5. *Fixing the antenna and optimizing the position of the ThermiCam AI devices*
- For PoE installation
 1. *Mounting the ThermiCam AI devices on a stable pole*
 2. *Connecting the connector to the cable*
 3. *Mounting the connector with cable on the device*
 4. *Fixing the antenna and optimizing the position of the ThermiCam AI devices*

7.2 Installation tools required but not included with ThermiCam AI

Tool	Purpose
Stainless steel retaining straps or bolts and washers M8	To mount ThermiCam AI on the pole
N°13 wrench	To tighten the stainless steel M8 bolts
Hex key n° 4	
PSU, min. 12 - max. 60 V DC	For BPL installation, to power TI BPL3 and all connected devices
Standard 3 wire installation cable no multi-cables (crosstalk) Ø = [5 - 10] mm Maximum cable length: 300 m / 1000 ft Required number of wires: 3 (+, -, FE)	To connect ThermiCam AI to TI BPL3
Network cable (Cat 5e)	To connect TI BPL3 to the network
PSU, min 24 - max. 48 V DC	For PoE installation, to power FLIR PoE Interface and all connected devices
Cable, UTP Cat 5e or better Ø = [4 -9] mm Maximum cable length: 100 m / 300 ft Required number of wires: 8 (4 ETH, 3+1 OUTPUTS)	For PoE installation, to connect ThermiCam AI to the network
Cutter, stripper pliers	To dismantle the installation and Cat 5e cable and strip the cable wires
Wire ferrules	To make sure there is no bad connection due to separating wires in the installation and Cat 5e cables
Screwdriver	To fix the cable wires to the connectors

 NOTE
<ul style="list-style-type: none"> • Power consuming loads other than the sensors are not allowed on the supply connection of the sensor ports. • If power-line (BPL) communication is used: <ul style="list-style-type: none"> ◦ Interconnection from interface to sensors must be carried out using separate installation cable(s), not used for any other purpose. Multi-purpose multi—wire cables are not allowed. ◦ Separate (single) wires are not allowed for interconnection, only cables are acceptable. ◦ Keep cable wires for any BPL connection as short and tight together as possible. ◦ Minimize number of cable transitions. ◦ Sensors and their cables on different networks should be separated by a distance of at least 1 meter to guarantee performance, except at interconnection with interfaces in a cabinet. • Take energy loss due to long cables into account for power supply calculation.

7.3 Power Requirements for TI BPL3 (to sensors)

The overall FLIR Traffic Detection System may be powered with its own Dedicated Supply or from a Power Distribution System. That power supplying circuit (directly connected to the FLIR Traffic detection system) from either origin may be earthed or not at the installer's discretion. Particular sufficient requirements to maintain safety in each scenario are described in the table below, although not all possibilities are mentioned. Should you have a power scenario different from the description in the table below, consult our service department for assistance.

Power Scenario	Earthed	Requirements
Dedicated Power Supply <ul style="list-style-type: none"> • AC or DC • Simple application • Recommended 	Yes	<ul style="list-style-type: none"> • Traffic detection system supply installation cables should be insulated withstanding 1500Vpeak for 60s at least. • Power supply unit should comply with IEC61558 or SELV or equivalent to one of both. • Power supply unit shall be over-current protected on its output circuit (secondary). • Power supply unit rating shall be in accordance with power tables 7.1 and 7.2 below, covering <ul style="list-style-type: none"> ◦ Maximum Interface power consumption ◦ Maximum Sensors power consumption ◦ Maximum Cabling losses.
	No	
Power Distribution System <ul style="list-style-type: none"> • AC or DC Mains • Specialist application 	Yes	<ul style="list-style-type: none"> • Power Distribution System installation cables should be insulated withstanding 1500Vpeak for 60s at least. • Power Distribution System shall be over-current protected with expected short circuit currents not exceeding 1000A. • Power Distribution System shall be insulated from hazardous voltages in the sense of IEC61140 (>120V DC / >50V AC). <ul style="list-style-type: none"> ◦ IF Class I Equipment is used as source, applied basic insulation shall withstand 2500Vpeak for 60s at least. ◦ IF Class II Equipment is used as source, applied Double or Reinforced insulation shall withstand 4000Vpeak for 60s at least. • Equipment used as source that complies with IEC61558 or SELV covers the insulation requirement.
	No	

7.4 Typical use case power cable

7.4.1 BPL

The following table gives you a simplified overview of a default cable size based on PSU, number of sensors and cable length in a star and bus topology.

For more in-depth information on recommended (low energy loss on cables) and allowed installation (high energy loss on cables) see annex.

NOTE	
<ul style="list-style-type: none"> • Product terminals do not support high wire gauges. Use junction box with short as possible branching cables <ul style="list-style-type: none"> ◦ For sensors : Branch cable AWG16 or equivalent with length <10m ◦ For TI BPL3 : Branch cable AWG16 or equivalent with length <1m • Conductors are assumed to be copper below 60°C • INSTALLATION RECOMMENDATIONS: <ul style="list-style-type: none"> ◦ Keep cable end-wires for connection as short and tight as possible. Never coil wires. ◦ Minimize number junctions and/or cable transitions ◦ Do not use loose wire to make BPL interconnections (Wire ≠ Cable) ◦ Do not use multi purpose cables for BPL connections ◦ Connect sensors as short as possible to local earth for optimized ruggedness 	

Table 7.1 Recommended cabling with average cable power loss <10% and peak cable power loss <15%

Number of sensors	PSU T-ambient < 50°C	STAR TOPOLOGY Min. cable size with cable length < 300m	BUS TOPOLOGY Min. cable size with cable length < 300m
TI BPL3 with 1 to 4 sensors	48 V DC / 80W	0,75 mm ² or AWG19	2,5 mm ² or AWG13

Table 7.2 Allowed cabling with average cable power loss <23% and peak cable power loss <45%

Number of sensors	PSU T-ambient < 50°C	STAR TOPOLOGY Min. cable size with cable length < 300m	BUS TOPOLOGY Min. cable size with cable length < 300m
TI BPL3 with 1 to 4 sensors	48 V DC / 120W	0,5 mm ² or AWG22	1,5 mm ² or AWG16

7.4.2 PoE

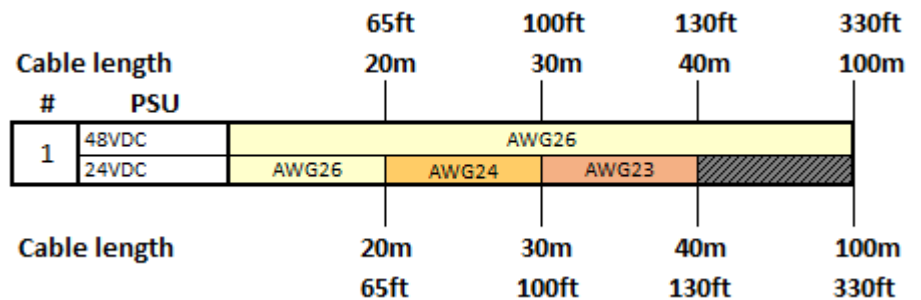

Figure 7.1 Recommended cabling with low peak cable power loss <15% (DC)

Cable length		165ft	295ft	330ft
		50m	90m	100m
#	PSU			
1	48VDC	AWG26		
	24VDC	AWG26	AWG24	AWG23
Cable length		50m	90m	100m
		165ft	295ft	330ft

Figure 7.2 Allowed cabling with high peak cable power loss <45% (DC)

7.5 BPL installation

7.5.1 Mounting the ThermiCam AI devices on a stable pole

Installation height: 3.5-15 m or 11.5-50 ft depending on the application. See 6.4 *Defining installation height, position and orientation for minimal occlusion*, page 21 for more installation guidelines.

	CAUTION
If the sensor is exposed to direct sunlight, the sunshield must be used to ensure minimum product lifetime.	

1. Fix the tube to the brackets (Torque max = 1.3 Nm / 0.95 ft lb).
ThermiCam AI is a downwards looking device with the detection LED at the bottom side of the sensor.

	WARNING
Product should never be opened, no serviceable parts inside. Opening the device will jeopardize the product integrity and void warranty.	



2. Fix ThermiCam AI to the pole using stainless steel retaining straps or stainless steel bolts and washers M8.
Put the stainless steel retaining straps through the parallel slots on the side of the bracket.
Alternatively, put the stainless steel bolts through the central holes of the bracket and tighten them using a N°13 wrench.

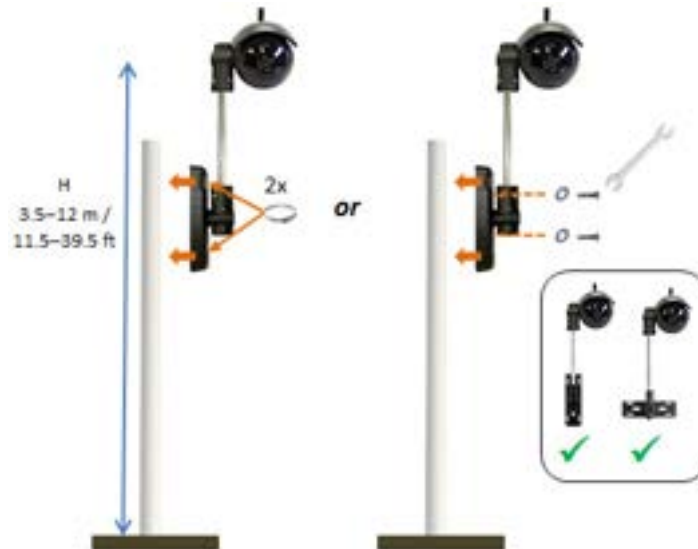

3. Position ThermiCam AI provisionally and fix the mounting brackets (Torque max = 1.3 Nm / 0.95 ft lb).
You can mount ThermiCam AI on a horizontal or vertical pole or on a mast arm.

7.5.2 Connecting the connector to the cable

	NOTE
<ul style="list-style-type: none"> • Check if the correct sealing is installed within the cable holder (c). If your cable is > 7 mm, insert the internal seal included in the package. • Recommended wire gauge for cable connector is 0,5mm² - 1mm² or 24AWG - 17AWG. For thicker wires, we recommend using an external connection box. 	

1. Put the installation cable (3 wires) through the cable gland (d) and holder (c).
2. Dismantle the cable (+/- 25 mm or 0,8 in) and strip the cable wires (+/- 6 mm or 0,24 in).
If you are using a flexible stranded wire, use wire ferrules to make sure there is no bad connection due to loose hanging wires.
3. Connect the cable to the 8-pole connector (b).

	NOTE
<p>Pins 1-2 and 3-4 are connected with bridges, so you can connect the BPL A wire in pin 1 or 2 and the BPL B wire in pin 3 or 4.</p>	

4. Tighten the cable holder (c) hand tight until you reach the blocking ridge.

5. Use the supplied wrench tool to tighten the cable gland (d) until you hear several clicks.

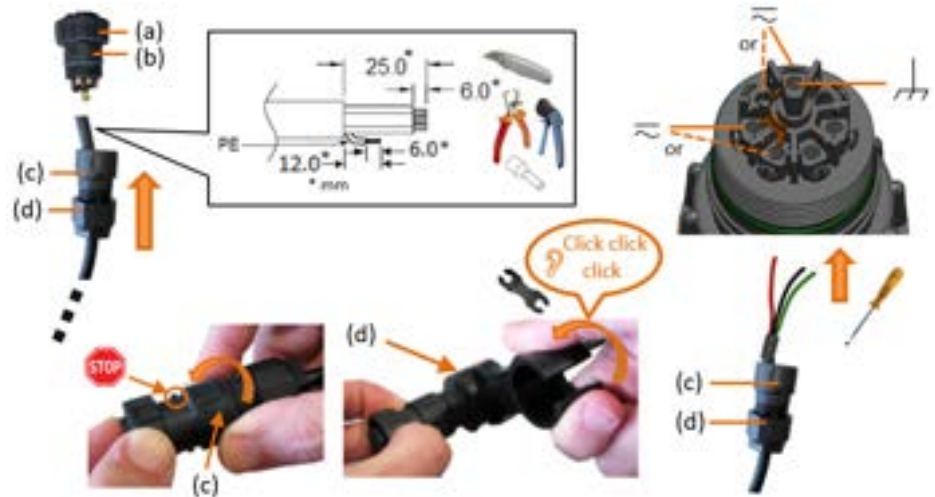

7.5.3 Mounting the connector with cable on the device

1. Remove the plastic protective cap from the device and mount the connector with cable on the device. Mind the slot for correct mounting.
2. Tighten the connector until it clicks.



WARNING

- Do not use any tools !
- Take minimum cable bending radius into account to avoid damage to the connector and sealing.

7.5.4 Connecting ThermiCam AI to TI BPL3 and the controller

1. To mount the TI BPL3 interface in the cabinet, do one of the following:
 - Place the interface on a shelf.
 - Fix the mounting clips on the side of the interface using the 2 screws M4x6 (torq 1Nm).



Click the interface on a DIN rail by pressing the lower end of the interface on the rail until you hear it click.

**NOTE**

The small screws to attach the back PCB to the box are in a small plastic bag together with the DIN-rail brackets.

2. On the backside of TI BPL3 interface, do the following:
 - a. Connect the wires of the power cable to the SENSORS connector.
 - b. Connect the OUTPUTS and ERR connectors to the traffic light controller.
 - c. Connect the power supply to the PWR connector.

3. Connect the TI BPL3 interface to the network using the LAN connector on the front panel.

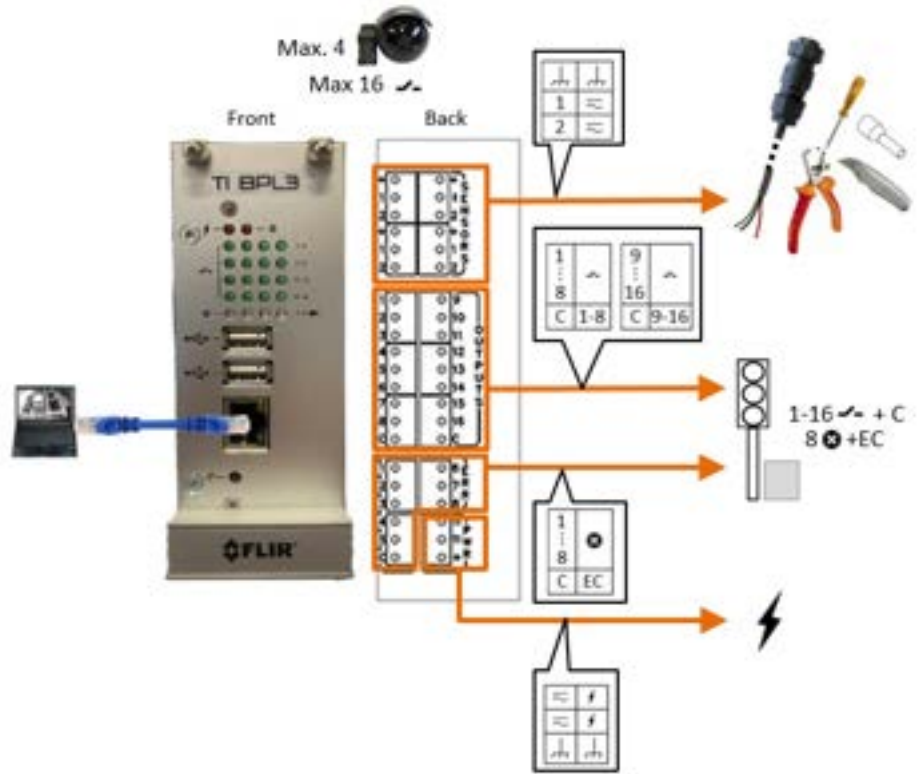

Figure 7.3 Connecting the TI BPL3 interface to ThermiCam AI and the controller

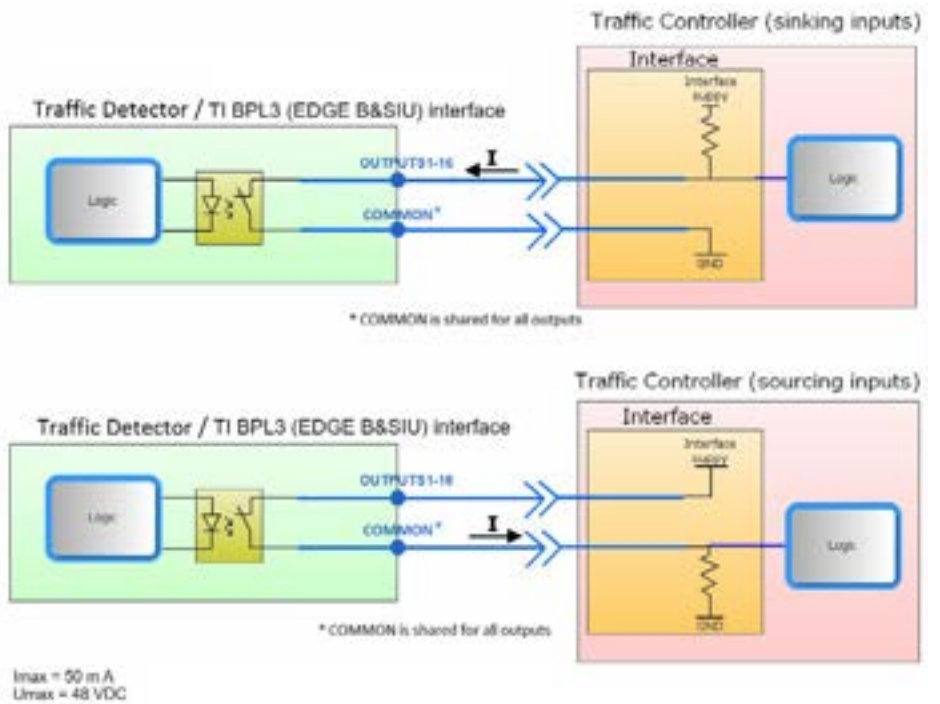

Figure 7.4 Output wiring diagram



7.5.5 Fixing the antenna and optimizing the position of the ThermiCam AI devices

1. Fix the antenna to the back of ThermiCam AI and tighten the antenna as much as possible by hand.
Use the antenna as lever. Do not use external tools to avoid damage to the antenna.
Make sure the antenna is perpendicular to the ground.
2. Connect the power supply and the PC to the network.
3. Verify the position of ThermiCam AI by viewing its sensor image using the web interface. See 10.2 *Live View*, page 43.
The device should be installed with a tilt angle between 0° and 90°. For best contrast results, include 10% visible horizon in the camera image. See 6.4 *Defining installation height, position and orientation for minimal occlusion*, page 21.
4. Tighten all screws.

7.6 PoE mode A installation

7.6.1 Mounting the ThermiCam AI devices on a stable pole

Installation height: 3.5-15 m or 11.5-50 ft depending on the application. See 6.4 *Defining installation height, position and orientation for minimal occlusion*, page 21.

	CAUTION
If the sensor is exposed to direct sunlight, the sunshield must be used to ensure minimum product lifetime.	
	NOTE
For more installation guidelines, see 6.4 <i>Defining installation height, position and orientation for minimal occlusion</i> , page 21.	

1. Fix the tube to the brackets (Torque max = 1.3 Nm / 0.95 ft lb).
ThermiCam AI is a downwards looking device with the detection LED at the bottom side of the sensor.

	WARNING
Product should never be opened, no serviceable parts inside. Opening the device will jeopardize the product integrity and void warranty.	



2. Fix ThermiCam AI to the pole using stainless steel retaining straps or stainless steel bolts and washers M8.
Put the stainless steel retaining straps through the parallel slots on the side of the bracket.
Alternatively, put the stainless steel bolts through the central holes of the bracket and tighten them using a N°13 wrench.

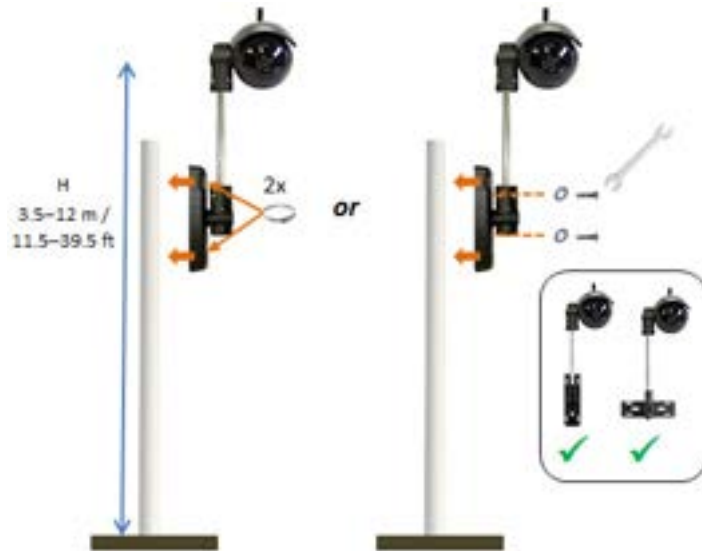

3. Position ThermiCam AI provisionally and fix the mounting brackets
(Torque max = 1.3 Nm / 0.95 ft lb).
You can mount ThermiCam AI on a horizontal or vertical pole or on a mast arm.

7.6.2 Connecting the connector to the cable



NOTE

Check if the correct sealing is installed within the cable holder (c). If your cable is > 7 mm, insert the internal seal included in the package.

1. Put the CAT 5e UTP cable through the cable gland (d) and holder (c).
2. Dismantle the cable (+/- 25 mm or 0,8 in) and strip the cable wires (+/- 6 mm or 0,24 in).
If you are using a flexible stranded wire, use wire ferrules to make sure there is no bad connection due to loose hanging wires.
3. Use a screwdriver to remove the bridges between connector pins 1–2 and 3–4.



4. Connect the CAT 5e UTP cable to the 8-pole connector (b).
5. Tighten the cable holder (c) hand tight until you reach the blocking ridge.
6. Use the supplied wrench tool to tighten the cable gland (d) until you hear several clicks.



7.6.3 Mounting the connector with cable on the device

1. Remove the plastic protective cap from the device and mount the connector with cable on the device. Mind the slot for correct mounting.
2. Tighten the connector until it clicks.



WARNING

- Do not use any tools !
- Take minimum cable bending radius into account to avoid damage to the connector and sealing.

7.6.4 Connecting ThermiCam AI to FLIR PoE interface and the controller

For more information on the connections of the FLIR PoE interface, see 5.6.2 *Pin Assignment and Connections*, page 17.



NOTE

Before you start, make sure the cabinet is fireproof !

1. Mount the PoE interface on a 35mm DIN rail in accordance with EN60715.

**WARNING**

The cabinet in which the PoE interface is installed, shall act as a fire enclosure and is therefore made of: non-combustible material (e.g. metal, glass, ceramic) OR V-1 class material.

- a. Tilt the PoE interface up and position it on the DIN rail as illustrated below.



- b. Tilt the PoE interface back down until it touches the DIN rail.
- c. Press the RJ-45 connector until you hear the PoE interface lock on the DIN rail with a click.



- d. To reduce the likelihood of sustaining flaming or spread of fire in the cabinet, make sure there is a clearance of 50mm above and below the unit and a lateral distance of 20mm to other units to guarantee sufficient separation between combustible materials.

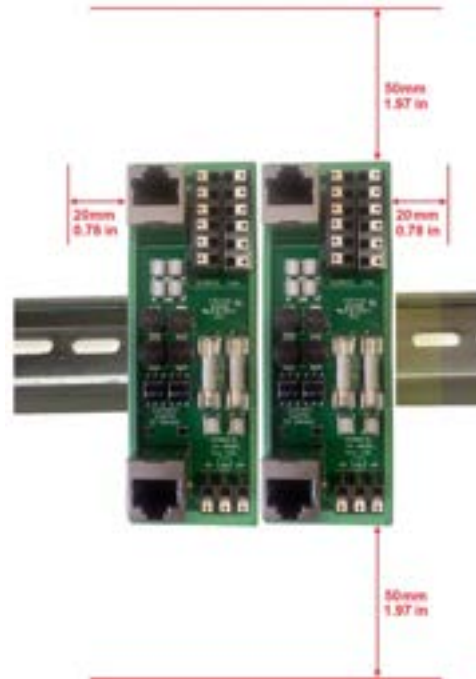

2. Make sure there is a solid connection from the protective earth terminal on the PoE interface to the earth.
3. Connect the PC (LAN port) or Network switch to the DATA IN RJ-45 connector of the PoE interface.
4. To make the connection between sensor (Cat5 cable) and the PoE Data Output, do one of the following:
 - Insert the RJ45 cable connector into the RJ45 jack.
 - Strip the wire ends (8 mm) of the Cat5 cable, mount the ferrules (cross section of wire min. AWG24/0,34 mm², max. AWG16/1,5 mm²) and connect them onto the push-in contacts of the terminal block.
5. Connect the sensor outputs of the PoE interface (push-in contacts of the terminal block) to the traffic light controller.

Before you can configure the system and view streaming video, you have to connect to the ThermiCam AI system.

8.1 Wireless over Wi-Fi

1. Use a PC, laptop, tablet or smart phone to connect to the ThermiCam AI Wi-Fi. For easy recognition, the name of the ThermiCam AI Wi-Fi contains the serial number (TRCXXXXXX) of the device. The serial number is located on the label on the back of ThermiCam AI.



NOTE

Default Wi-Fi password = **FlirtsWiFi**

2. Open a web browser and go to <http://www.thermicamai.com>. The ThermiCam AI web interface opens and displays the live view.

8.2 Connecting to ThermiCam AI with known IP address

1. Make sure your PC has a fixed IP address assigned and is not on DHCP.
2. Make sure your PC and ThermiCam AI are in the same network range.
3. Open a web browser and enter the IP address of ThermiCam AI. The web interface of ThermiCam AI is displayed.

8.3 Connecting to ThermiCam AI with IP address unknown

When you do not know the IP address of ThermiCam AI, you can still connect to the system via the Scan Network Tool.

1. Make sure your PC has a fixed IP address assigned and is not on DHCP.
2. Change the IP address of your PC to 10.0.0.x (where x is not 0, 1 or 255) and subnet mask 255.0.0.0.
3. Download and install the Scan Network Tool from AMS public zone on Box.
4. Start Scan Network Tool.
5. Click *Scan Network*.

Scan Network Tool will scan the network and will give you an overview of all devices on the network, their name, IP address and port information.

All devices connected to a TI BPL3 interface have the same IP address as the interface but with a different port number.

Devices with an IP address that is not in the network range are listed as unknown devices.



6. Do one of the following:

- To connect to the devices of which the name, IP address and port information are displayed, open the web interface by clicking the device.

Alternatively, you can copy the URL of the device by clicking  and pasting it in a web browser.

- To connect to an unknown device, do one of the following:
 - Change the IP address of your PC so that it is in the same network range as the unknown device.
When clicking *Scan Network*, the previously unknown device will now be displayed with its name, IP address and port number and you will be able to open the web interface by clicking the device.

- Reassign the IP address of the unknown device as follows :

- In the Scan Network Tool, next to the unknown device, click  (*Edit IP settings*)



- Change the IP address of the device so that it is in the same network range as your PC.
- Click *Apply*.
- Click *Scan Network*.
The device is now displayed with its name, IP address and port number and you will be able to open the web interface by clicking the device.

9.1 Supported web browsers

The web interface allows a unified experience across platforms and device sizes. The interface adapts itself to the device you are viewing it on, i.e smartphone, tablet or desktop/PC. Input can be done via keyboard/mouse or touch.

The web interface can be used on the following browsers:

		Chrome	Firefox	Safari
Desktop/Laptop	Windows	✓	✓	
	Linux	✓	✓	
	Mac	✓	✓	✓
Tablet	iPad	✓		✓
	Android	✓		
Smartphone	iPhone	✓		✓
	Android	✓		

9.2 Layout

The web interface can be viewed in portrait or landscape. The camera image and video are always as large as possible.

- Landscape view: Buttons and settings are located left of the image.
- Portrait view: Buttons and settings are located below the image.

**NOTE**

When connecting to a ThermiCam AI device that is managed by a TI BPL3 interface, you will automatically be directed to the TI BPL3 web interface instead of the ThermiCam AI web interface.

10.1 Navigation pane

The navigation pane in the TI BPL3 web interface allows you to navigate to the following pages:

- **Live View:** displays live video from all connected devices.
- **Configuration**
 - **Outputs:** allows you to test the outputs of the interface.
 - **Error Outputs:** allows you to assign the error outputs.
 - **Network:** allows you to modify the network settings, i.e. IP, Wi-Fi and SNMP settings, manage the connected devices and test the connection with the internet.
- **Administration**
 - **General:** allows you to define the general and time settings, set the temperature threshold, reload a configuration, reset the configuration to the factory default, reboot the device and download and upload a configuration or offline network.
 - **Firmware:** allows you to load the firmware.
 - **Users:** allows you to add, edit and remove users.
 - **Technical Event Log:** allows you view, filter, export and reset the log file of the technical events.
 - **System Log:** allows you to download or reset the system log.
 - **Product Security:** allows you to manage services, user authentication, physical access and certificates and view and export the physical access and user log.

10.2 Live View

The Live View page displays a static camera image of all connected devices.



Do one of the following:

- A. Click  in the top left corner of the navigation pane to open the connected devices pane and click the corresponding device to open its web interface.





The web interface opens in a separate tab. To return to the TI BPL3 web interface, go back to the interface tab and click the TI BPL3 in the devices pane.

- B. To open the web interface of the device, click the static camera image. The web interface opens in a separate tab.
- C. To view streaming video of a device within the web interface, click  at the bottom of the corresponding static camera image. See 33.3 *Viewing streaming video via the web interface*, page 92.



**NOTE**

You can also view streaming video via rtsp using VLC media player, see 33.3 *Viewing streaming video via the web interface*, page 92.

- D. To maximize the streaming video view within the web interface, click . To minimize the maximized streaming video view, click .
- E. To pause streaming video of a device within the web interface, click  at the bottom of the corresponding static camera image. See 33.3 *Viewing streaming video via the web interface*, page 92.
- F. To view the outputs of the interface, click the arrow at the bottom of the page.

10.3 Outputs

The Outputs page shows you the actual status of the outputs and allows you to test the outputs of the interface.

1. Go to *Configuration > Outputs*. The actual status of the outputs is displayed:
 - Unassigned outputs are grey
 - Assigned outputs are blue
 - Assigned outputs on which there is currently detection are Orange.
2. To start the test mode, click . By default all outputs are set to “Off”, regardless of their actual status.
3. Test the outputs and check whether the corresponding output LEDs on the interface are activated:
 - a. Click a test output to activate it. The test output turns orange and the output LED should be on.
 - b. Click an active test output to deactivate it. The test output turns blue and the output LED should be off.
4. To stop the test mode, click . The actual status of the outputs is displayed again.

10.4 Error outputs

In case of communication errors between the device and the interface, the TI BPL3 interface activates an error output. To suppress potential short self-correcting communication problems within one traffic cycle, you can set an error output delay. The error output delay starts as soon as a communication problem is detected with one of the sensors, but the error output is only activated once the delay has passed.

TI BPL3 has 4 error outputs, i.e. one for each device connected to the interface. They can be configured as follows:

1. Go to *Configuration > Error Outputs*.
2. Set the *Error Output Delay* (default: 0s).

3. To assign the error outputs, select or clear the check boxes as required.

	NOTE
<p>Under certain circumstances, more than 4 sensors can be connected to a TI BPL3 in case of defined power supply, cable length and wire section — see 37 <i>TI BPL3 Cabling — extended</i>, page 108.</p> <p>In that case, as there are only 4 error outputs for max. 8 sensors, some error outputs might have to be shared.</p>	

4. To save your configuration, click .

10.5 Network

For more information on the Network settings, see 13 *Network settings*, page 52.

The *Managed Devices* pane gives you an overview of all connected devices. When you change the Network settings for TI BPL3, the changes will be sent to all connected devices and you will no longer be able to edit the network settings of the individual devices.

10.5.1 Refreshing connected devices

Refresh the connected devices when you have made changes to the setup of TI BPL3, e.g. when devices were added or removed.

1. Go to *Configuration > Network*.
2. Switch to the *Managed Devices* pane.
3. Click *Refresh connected devices*.

10.5.2 Power toggling connected devices

In case of diagnostic problems, you can turn the power of the connected devices on and off.

1. Go to *Configuration > Network*.
2. Switch to the *Managed Devices* pane.
3. Click *Power toggle connected devices*.

10.5.3 Updating the BPL channel

When using several TI BPL3 devices, always update the BPL Channel to avoid interference between the interfaces !

1. Go to *Configuration > Network*.
2. Switch to the *Managed Devices* pane.
 - a. To avoid interference between several sensors or TI BPL3 devices, under *Update the BPL channel* adapt the *Channel*.
Choose a channel between default (i.e. 0), 1, 2 and 3.
 - b. Click *Apply channel key and update connected devices*.
All devices connected to the same TI BPL3 will be set to the same channel.

The time on those devices is synchronized with the time of the TI BPL3. NTP synchronization is no longer possible.

10.5.4 Adapting the port numbers of the connected devices

The Managed Devices pane of the Network page of the interface gives you an overview of the connected devices.

1. Go to *Configuration > Network > Managed Devices*.

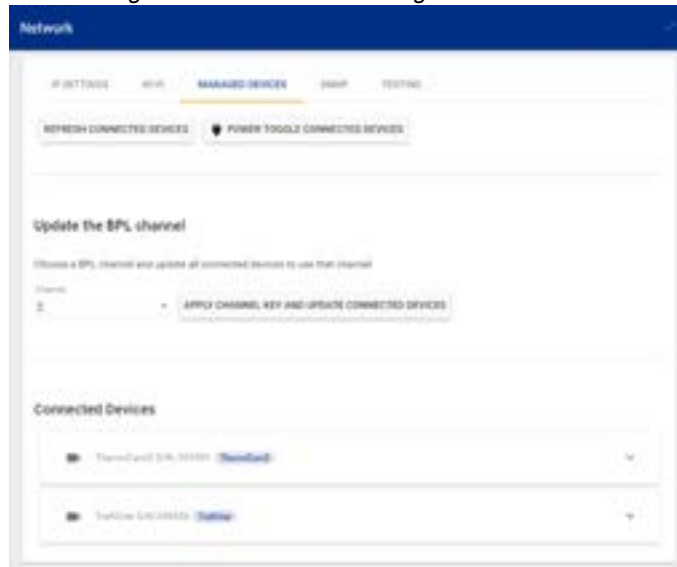

2. Under *Connected Devices*, click the device for which you want to adapt the port numbers.

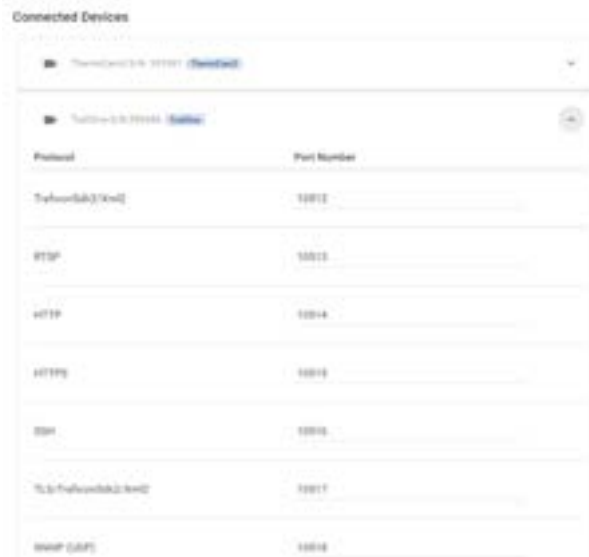

3. Click a Port number and adapt as necessary.

4. To save your configuration, click .

10.6 Administration

10.6.1 General

For more information on the general settings and time settings, see 12 *General settings*, page 49.

10.6.2 Firmware

Select the sensors for which you want to upgrade the firmware.

**NOTE**

- When upgrading interface firmware, make sure to only select the TI BPL3 .
- When upgrading sensor firmware, make sure to only select sensors.

For more information on firmware upgrades, see 35.2 *Firmware upgrade of ThermiCam AI*, page 100.

10.6.3 Users

For more information on adding, changing and removing users, see 14 *User Management*, page 54.

10.6.4 Technical event log

Select the devices for which you want to see the technical events.

1. Go to *Administration > Technical Event Log*.
2. Click *Show Filter*.
3. Under *Device*, clear the check boxes of the devices for which you do not want to see the technical events.
Alternatively, to show all devices again, click *Reset Filter*.

For more information, see 35.3 *Technical Event log*, page 100.

10.6.5 System logs

For more information on downloading the system log, see 35.4 *System log*, page 101.

10.6.6 Product security

For more information on services, user authentication, physical access, certificates, physical access log and user log, see 14 *User Management*, page 54.

11.1 Navigation pane

The navigation pane in the web interface allows you to navigate to the following pages:

- **Live View:** displays live video from ThermiCam AI.
- **AI Detection**
 - **Calibration:** allows you to calibrate the ThermiCam AI device.



NOTE

The Calibration under AI Detection and VA Detection is the same. Changes made in one calibration will automatically be synchronized with the other calibration.

- **Zones:** allows you to draw detection zones.
 - **Trajectories:** allows you to create a path from one detection zone to another.
 - **Applications:** allows you to add the following applications: Presence, Counting Group, Queue Occupancy, Bicycle Presence, Pedestrian Presence, Wrong Way Driver (license required), Custom application.
 - **Setup Detection:** allows you to link a zone or trajectory to an application, either by using the list view or the matrix view.
 - **Settings:** allows you to change the track data settings (license required).
- **VA Detection**
 - **Calibration:** allows you to calibrate the ThermiCam AI device.



NOTE

The Calibration under AI Detection and VA Detection is the same. Changes made in one calibration will automatically be synchronized with the other calibration.

- **Zones:** allows you to draw traffic data zones and masking zones.
 - **Settings:** allows you to set the Thermal Quality Threshold and to configure the traffic data settings.
- **Configuration**
 - **Outputs:** allows you to assign the outputs.
 - **Video:** allows you to define the video compression settings.
 - **Camera:** allows you to set the thermal region of interest.
 - **Network:** allows you to modify the network settings.
 - **Display:** allows you to define the overlay.
 - **Administration**
 - **General:** allows you to define the general and time settings and language, set the temperature threshold, set the gps position of the device, reload a configuration, reset the configuration to the factory defaults, reset all users, reboot the device, import and export configurations and offline networks.
 - **Firmware:** allows you to load the firmware.
 - **Users:** allows you to add, edit and remove users.
 - **Licensing:** allows you to select and install licenses.
 - **Technical Event Log:** allows you view, filter, export and reset the log file of the technical events.
 - **System Log:** allows you to download and reset the system log.
 - **Product Security:** allows you to manage services, user authentication, physical access and certificates and view and export the physical access and user log.

12.1 Adapting the general settings

1. Go to *Administration > General*.
2. Under *Settings*, do one of the following:
 - To change the *Device name*, click it.
 - To change the *Locale*, click it and select EU or US.
When set to US, all events and overlay will be in imperial measurements.
 - To deactivate the detection LED on ThermiCam AI, click *Detection Led*.

 NOTE
This setting is not available on the TI BPL3 interface.

See 5.2.3 *LED indicator code*, page 11.

3. To save your configuration, click .

 NOTE
For more information on the <i>Reload configuration</i> , <i>Reset to default</i> , <i>Reset all users</i> and <i>Reboot</i> button, see 30.4 <i>Restarting ThermiCam AI with the current or factory default configuration</i> , page 85.

12.2 Adapting the language of the user interface

1. Go to *Administration > General*.
2. Switch to the *User preferences* pane.
3. Select a *Language*.
The Web interface is available in German, English, Spanish, French, Italian, Portuguese, Russian and Chinese.
4. To save your configuration, click .

12.3 Adapting the temperature threshold

The temperature threshold is by default set to 70°. When the temperature threshold is exceeded, ThermiCam AI generates a technical event “Temperature” in XML2 and public API.

 NOTE
When ThermiCam AI is used with TI BPL3 , the temperature threshold must be configured on the interface.

1. Go to *Administration > General*.
2. Switch to the *Technical events* pane.
3. To change the *Temperature Threshold* (default 70°), click the up and down arrows or type in a new value.
4. To save your configuration, click .

12.4 Setting the GPS position of the device

1. Go to *Administration > General*.
2. Switch to the *GPS position* pane.

3. Fill in the following coordinates :

- Latitude
Distance measured in degrees north and south from the equator.
- Longitude
Distance measured in degrees east and west from the prime meridian
- Heading
Compass orientation of the camera itself with North = 0°, East = 90°, South = 180° etc.

4. To save your configuration, click .

12.5 Adapting the time settings

	NOTE
When ThermiCam AI is used with TI BPL3 , time settings must be configured on the interface.	

1. Go to *Administration > General*.
2. Switch to the *Time* pane.
3. Do one of the following:
 - To switch to a different *Time Zone*, click and select one.
 - To synchronize the time of ThermiCam AI with the clock of the NTP server, select *NTP* and enter the *NTP server name*.
 - To stop time synchronization with the NTP server and manually enter the date and time:
 - a. Clear the *NTP* check box.
 - b. Click *Edit*.

	NOTE
If the <i>Edit</i> button is disabled, click  to save any pending changes in your configuration.	

- c. Enter the date (DD/MM/YYYY) and time.
 - d. To save the time, click *Set Clock*.
 - To stop time synchronization with the NTP server and synchronize the date and time with that of your PC, click *Synchronize Clock*.
4. To save your configuration, click .

12.6 Importing and exporting configurations and offline networks.

For more information, see 30.3 *Exporting and importing a configuration or offline network*, page 85.

12.7 Viewing general information about the device

1. Go to *Administration > General*.
2. Switch to the *About* pane.

The following information is displayed:

- Name
- Serial Number
- Product
- Firmware version
- Hardware revision

 NOTE
<p>When setting up your network or switch, please make sure the following ports are allowed :</p> <ul style="list-style-type: none"> • TCP ports : <ul style="list-style-type: none"> ◦ 22 ◦ 80 (http) ◦ 443 (https) ◦ 554 (rtsp) ◦ 5000 and 6000 (xml2) • UDP ports : <ul style="list-style-type: none"> ◦ 161 (SNMP) ◦ 3702 (ONVIF)

13.1 Adapting the IP settings

 NOTE
When ThermiCam AI is used with TI BPL3 , IP settings must be configured on the interface.

1. Go to *Configuration > Network*.
2. Under *IP settings*, adapt any of the following:
 - *Default Gateway*
 - *Name Server*
 - *IP Address*
 - *Subnet Mask*
 - Alternatively, to automatically get an IP address from the DHCP server, turn on *DHCP*.
3. To save your configuration, click .

13.2 Adapting the Wi-Fi settings

1. Go to *Configuration > Network*.
2. Switch to the *Wi-Fi* pane and do any of the following:
 - To disable the Wi-Fi, set the *Wireless Mode* to *Off*.
 - In all other cases, set the *Wireless Mode* to *Access Point*.
 - Only when ThermiCam AI is not used with TI BPL3 :
 - To change the name of the Wi-Fi network, adapt the *Wireless Network Name (SSID)*.
 - To not display the Wi-Fi network in the list of available wireless networks, turn on *Hide SSID*.

 NOTE
Even though the Wi-Fi is not displayed, you can still connect to it.

- Adapt the *Wifi Password (WPA Shared Key)*.
 - To avoid interference between several ThermiCam AI devices, adapt the *Wireless Channel*.
Choose a channel between 1 and 11. Make sure not all ThermiCam AI devices are on the same channel.
3. To save your configuration, click .

13.3 Specifying the host for SNMP traps

Please contact the FLIR ITS Support team for the MiB file.

The following data is supported over SNMP:

- sysUpTimeInstance
- brand
- model
- applicationVersion
- bootloaderVersion
- serialNumber
- firmwareDate

ThermiCam AI can be configured with an SNMP trap for a specific IP-address. When the SNMP trap is configured, no-video events will be sent to the specified SNMP trap receiver (port 162).

1. Go to *Configuration > Network*.
2. Switch to the *SNMP* tab.
3. Under *Trapsink*, specify the IP address of the host that will receive the SNMP traps.
4. To save your configuration, click .

13.4 Connecting to the Acyclica cloud and enabling Wi-Fi Scanning for travel time calculation

1. Go to *Configuration > Network*.
2. Switch to the *Cloud* pane.
3. To automatically connect to the Acyclica cloud, select *Acyclica Cloud Service*.
4. To monitor mac addresses and send them to the Acyclica cloud, select *Wi-Fi scanning*.
5. Enter the *Cloud server address* and the *Proxy*.
By default, the cloud server address is set to `data.acyclica.com`.
Configure the Proxy server IP address if this is used on the network.
6. To push all generated events to FLIR Cascade, select *Push protocol* and specify the URL of FLIR Cascade as *Endpoint*.
7. To save your configuration, click .

13.5 Testing the network

1. To check whether ThermiCam AI can access the internet, do one of the following:
 - Enter a *Domain Name*.
 - Enter a *Name Server*
2. Click *Apply*.

**NOTE**

When ThermiCam AI is used with TI BPL3 , user management is done on the interface.

14.1 User roles

Define the users that are allowed to log on to ThermiCam AI and their role.

- A viewer can only access Live View and the check the state of the outputs. See 33.3 *Viewing streaming video via the web interface*, page 92.
- Admin users have access to all functionality.

14.2 Adding a new user

1. Go to *Administration > Users*.
2. Under *Add new user*, specify the following :
 - Username
 - Role, i.e. Viewer or Administrator
 - Password
Repeat the password in the *Confirm password* field.
3. Click *Add*.
The user is added to the Overview.

14.3 Changing the user settings

1. Go to *Administration > Users*.
2. Under *Overview*, click *Edit* next to the user for which you want to change the settings.
3. Change the following fields as required:
 - Username
 - Role, i.e. Viewer or Administrator
 - Password
Repeat the password in the *Confirm password* field.
4. Click *OK*.

14.4 Removing a user

1. Go to *Administration > Users*.
2. Under *Overview*, click *Remove* next to the user you want to remove.

The following features require a license:

- Wrong way driver
- Tracking road users (premium data)

15.1 Installing licenses

1. Go to *Administration > Licensing*
2. Click *Select license file*, locate and select the file on your pc and click *Open*
3. Click *Install license*.

16.1 Calibrating the device

Calibrate the device to make sure that the distances in your camera image match the real distances on the road.

1. Go to *AI or VA Detection > Calibration*.
2. Check and adapt the *Camera Height*.



NOTE

The *Camera Height* is the installation height of the camera in relation to the detection area. In most cases, the *Camera Height* corresponds to the actual installation height of the camera on the pole. If however, there is a significant elevation difference between the camera position and the detection area, this difference in elevation should be taken into account when defining the *Camera Height*.

3. Retrieve the current tilt angle from the device by clicking *Read current tilt angle from sensor*.

The tilt angle is displayed in the *Adjusted Tilt Angle* field.



NOTE

- This is a mandatory step as the camera may have saved another tilt angle in the previous or factory default configuration.
- If your road is an upwards or downwards slope, you can manually adjust the tilt angle to match the actual tilting angle in relation to your road.

4. Retrieve the current roll angle from the device by clicking *Read current roll angle from sensor*.

The roll angle is displayed in the *Adjusted roll Angle* field.



NOTE

This is a mandatory step as the camera may have saved another roll angle in the previous or factory default configuration.

5. To save your configuration, click .



NOTE

For more information on your calibration, click  in the top right corner of the camera image. The following information will be displayed:

- CCD Width
- CCD Height
- Focal distance
- FOV (degrees)
- Camera model
- Live measured tilt angle
- Live measured roll angle

16.2 Verifying the accuracy of calibration

The camera image in *Calibration* mode displays a frame of horizontal and vertical white lines that help you verify the accuracy of your calibration:

- Each vertical line (A in Figure 16.1 below) is 1m long.
- The vertical distance between 2 vertical lines is 1m.
- The horizontal distance between 2 vertical lines is 1,5m, 3 vertical lines (B in Figure 16.1 below), which are 3m wide, roughly correspond to the width of a traffic lane.

You can also verify the calibration by adding horizontal and vertical calibration lines.

1. Click  and do one of the following :

- To add a horizontal line in the camera image, click .
The horizontal line is displayed in light blue.

- To add a vertical line in the camera image, click .
The vertical line is displayed in purple.



NOTE

Make sure the horizontal line corresponds to a known distance on the ground plane, e.g. distance between 2 poles or the width of a traffic lane and the vertical line to a known height, e.g. of a pole.

2. With the line selected, check whether the line length that is displayed in the camera image corresponds to the actual distance or height.
3. If the actual distance or height does not correspond to the line length in the camera image, adapt the *Adjusted Tilt Angle*, *Pan angle* and *Adjusted roll angle* until it does.



NOTE

- Adjusting the tilt angle will move the horizon, i.e. the curved white line in the camera image, up or down.
This only applies when the horizon is visible in the camera image.
- Adjusting the pan angle changes the direction of the vertical white lines in the camera image.
Adjust the angle so that the lines correspond to the traffic direction.
- Adjusting the roll angle will roll the camera image to the left or right.
- If the tilt angle is not between 0 and 90, you will not be able to save the configuration.

4. To save your configuration, click .

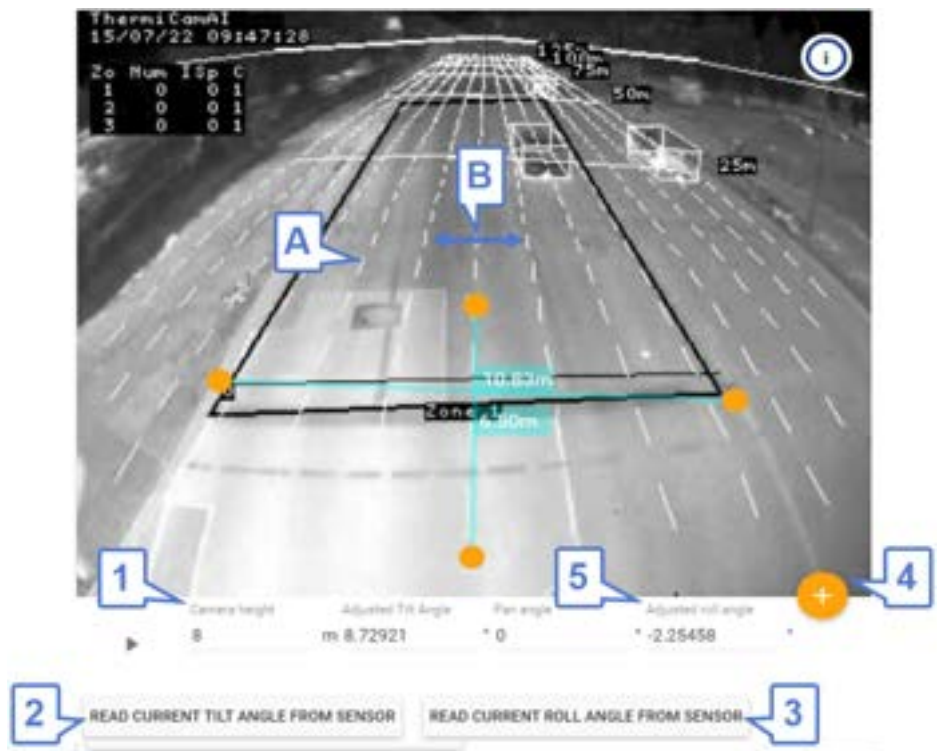

Figure 16.1 Calibration steps

1. Specify the installation height of ThermiCam AI.
2. Retrieve the current tilt angle from the sensor and display it in the *Adjusted Tilt Angle* field.
3. Retrieve the current roll angle from the sensor and display it in the *Adjusted Roll Angle* field
4. Click to add a horizontal or vertical line as reference or verification of the calibration.
5. Adjust the tilt, pan and roll angle until the length of the horizontal and vertical calibration lines in the camera image corresponds to the actual distance or height.

Adapting the Region Of Interest (ROI) of the thermal core for more contrast



17.1 When to adapt the ROI of the thermal core

In order to detect road users in an efficient way, it is crucial that you select the correct lens type. For more information, see 6.3 *Detection range chart*, page 21.



To have sufficient contrast in the camera image, it is crucial that you optimize the position of your camera so that 60-80% of the image is road and 40-20% is other (vegetation, buildings and a max of 10% sky).

If however, after following these guidelines, there is still not sufficient contrast in your camera image, you can adapt the Region of Interest (ROI) of the thermal core.

17.2 Adapting the ROI of the thermal core

1. Go to *Configuration > Camera*.
2. Turn *Set thermal region of interest* on.
The thermal region of interest is displayed in the camera image as an orange square.
3. Adjust the thermal region as required:
 - Adjust the size of the thermal region by dragging the bottom right corner.
 - Move the thermal region by clicking and dragging.
 - To set the entire screen as thermal region, click .
4. To save your configuration, click .

17.3 Displaying the ROI as overlay in the camera image

1. Go to *Configuration > Display*.
2. Under the camera image, click .
3. Go to the *Algorithm settings* and turn *Thermal core ROI* on.
4. To save your configuration, click .

18.1 How to use AI Detection

Use AI detection for detection of

- Presence
- Counting Group
- Queue Occupancy
- Bicycle Presence
- Pedestrian presence
- Wrong Way Driver
- Custom applications

18.2 Setting up AI detection

Setting up AI detection consists of the following steps:

1. Draw AI detection zones, see 19 *AI detection zones*, page 61.
2. Add trajectories as necessary, see 20 *Trajectories*, page 64.
3. Add applications, see 21 *Applications*, page 65.
4. Link the AI detection zones and trajectories to the applications, see 22 *Linking detection zones and trajectories to an application*, page 70.

 NOTE
<ul style="list-style-type: none"> This function requires calibration. See 16 <i>Calibration</i>, page 56.

19.1 How to use AI detection zones

Use AI detection zones to set up detection for:

- Presence
- Counting groups
- Queue Occupancy
- Bicycle Presence
- Pedestrian presence
- Wrong Way Driver
- Custom applications

For more information on how to set up the above applications and link them to one or more detection zones, see 21 *Applications*, page 65 and 22 *Linking detection zones and trajectories to an application*, page 70.

19.2 Attributes of AI detection zones

AI detection zones have a polygon shape. By default, they consist of 4 zone points but you can add extra zone points by double clicking on the border of the zone.

You can define up to 32 AI detection zones. Each zone has the following attributes, as illustrated in the image below:

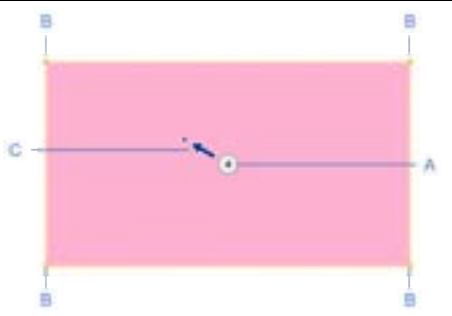
	<ul style="list-style-type: none"> • Zone ID (A), which is automatically assigned. • Zone points (B), by default 4, but you can add zone points by double clicking on the border of the zone and remove zone points by double clicking them. • Main direction, defined by the direction arrow and point(C)
--	--

19.3 Adding AI detection zones

Enable presence detection by adding AI detection zones.

1. Go to *AI Detection > Zones*.
2. To add a detection zone, click .



 NOTE
<p>You can add max. 32 AI detection zones. When the maximum amount is reached, the button is disabled.</p>

3. Place and size the zone by dragging and dropping the zone points.
To add an extra zone point, position the mouse on the border of the zone where you want to add the zone point until the cursor becomes a  and double click.
4. Shape the zone by adding additional zone points as necessary.
5. Set the direction of the zone by clicking the direction point and turning it in the main direction of traffic.
The direction of the zone is indicated by the blue arrow.

6. To save your configuration, click .

19.4 Duplicating AI detection zones

Duplicating a zone does not only copy the size and position of the selected zone, but also the zone settings.



1. Go to *AI Detection > Zones*.
2. Click the detection zone you want to duplicate.
If the zone is difficult to click because of overlapping zones, you can isolate a detection zone. See 19.5 *Isolating AI detection zones*, page 62.
3. Under the camera image, click .
4. To save your configuration, click .

19.5 Isolating AI detection zones

Isolation mode helps you to select and modify detection zones more easily.





1. Go to *AI Detection > Zones*.
2. Under the camera image, click *Isolate a zone* and select a zone.
3. To stop isolation, under the camera image, click the selected zone and select *Clear isolation*.
4. To save your configuration, click .

19.6 Deleting AI detection zones

1. Go to *AI Detection > Zones*.
2. Click the zone you want to delete.
If the zone is difficult to click because of overlapping zones, you can isolate a detection zone. See 19.5 *Isolating AI detection zones*, page 62.
3. Under the camera image, click .
4. To save your configuration, click .



19.7 Defining the zone name and characteristics

The zone name and characteristics are used in the real-time event messages, event reports and event filters in Flux and allow you to distinguish the zones on different lanes.

1. Go to *AI Detection > Zones*.
2. In the camera image, click the zone.
3. Under the camera image, click .
4. Enter the *Zone name*.
5. Under *Zone characteristics*, click .
6. Fill in the *Name* and *Value*.
7. To add other characteristics, repeat step 4 and 5.
You can define max. 16 characteristics.
8. To delete a characteristic, click .
9. To save your configuration, click .

19.8 Switching to the minimal user interface

By default, the user interface displays the zone ID for all zones. Switch to the minimal user interface if you do not want these to be displayed.

1. Go to *AI Detection > Zones*.
2. Under the camera image, click .
The zone ID is hidden for all zones.
3. To switch back to the full user interface, click  again.
The zone ID is displayed for all zones.
4. To save your configuration, click .

20.1 How to use trajectories

Use trajectories to link one detection zone to another. In order to get detected in a trajectory, an object has to move through the zones of that trajectory, in the set order. Detection will only be triggered when the object is in the destination zone of the trajectory.

20.2 Adding trajectories

1. Go to *AI Detection > Trajectories*.
2. To add a trajectory, click .
3. Click the zone in which the object has to start its movement and continue by clicking the next zones it has to move through, one by one, in the correct order until the trajectory is complete.
4. Under *Create new trajectory*, enter the *Name of the trajectory*.
5. Click *Done*.
The trajectory is added to *All trajectories*.

20.3 Removing trajectories

When an active application is linked to a trajectory, the application will be removed as well.

1. Go to *AI Detection > Trajectories*.
2. Under *All trajectories*, select the trajectory you want to remove.
3. Under *Update trajectories*, click *Remove*.
The trajectory is removed from *All trajectories*.



NOTE

Removing a trajectory, will also remove any active application linked to it.
See 21 *Applications*, page 65.

21.1 Adding applications

1. Go to *AI Detection > Applications*.
2. To add an application, click  and do one of the following:
 - Select one of the following predefined applications:

Application	Function
Presence	Detects all objects that are not bicycles or pedestrians and sends out a "Presence" event.
Counting group	Integrates data over a 60 seconds interval and sends out "Count" events.
Queue Occupancy	Detects all road users with a speed lower than 3.6 km/h and sends out a "Queue" level event when the set vehicle threshold in the queue is reached.
Bicycle Presence	Detects all bicycle and sends out a "Bicycle-Presence" event.
Pedestrian Presence	Detects all pedestrians and sends out a "PedestrianPresence" event.
Wrong Way Driver	Detects all road users that are not pedestrians in the opposite direction of the zone direction and sends out a "WrongWayDriver" event.

You can use all of the above applications with their predefined settings or alternatively, adapt the *Application name*, *Event settings* and click *Customize advanced settings* to adapt the filter criteria.

- Select *Default application* and set up your own custom application by defining the event type and filter settings from scratch.

See 21.1.1 *Event settings*, page 65 and 21.1.2 *Filter criteria*, page 68.



NOTE

You can add max. 20 applications. When the maximum amount is reached, the button is disabled.

3. To save your configuration, click .

21.1.1 Event settings

The following table gives you an overview of the available event types and settings.

Event type	Settings	Description
State event Sends out a Begin event when an object passes all filter criteria and an End event, when the object does no longer pass all filter criteria.	Startup recall timeout	Time (in seconds) during which detection in the zone is forced after startup, regardless of whether there are objects detected in the zone or not..
	Delay time	The time (in seconds) between detection of an object and activation of the event. If the delay time is longer than the time during which the object should have been detected, the event will not occur anymore, e.g. delay time is 2 seconds but a vehicle is only in the zone for 1 second.
	Extend time	The time (in seconds) after detection is dropped and the event is deactivated.
	Event name	Name of the event that will be sent out.
	Display event messages	Displays zone ID and event name in the overlay when an object is detected. To adapt the location of the overlay in the camera image, go to <i>Configuration > Display settings</i> and move the <i>AI Event Messages</i> display item.
	Send events	Sends out event messages when an object is detected. These event messages will also trigger the outputs.
Level event Sends out an event each time a certain level criteria has been reached: <ul style="list-style-type: none"> • When a level 2 event is reached, a Begin event is sent for level 2. • When level 3 is reached, a begin event for level 3 is sent, while level 2 remains open. • When level 3 stops, an End event for level 3 is sent. • When level 2 stops as well, an End event for level 2 is sent. 	Default flow speed	Default flow speed when there is no traffic. This should correspond to the speed limit in the zone.
	Flow speed integration buffer time	Buffer time for calculating flow speed average
	Event name	Name of the event that will be sent out.
	Type of level	Select one of the following: <ul style="list-style-type: none"> • Number of objects passing through the zone. • Length of the queue (in meter) in the zone. • Flow speed (km/h) of all objects passing through the zone. • Flow rate, i.e. the measured number of objects (volume) per minute passing through the zone.
	Send events	Sends out event messages when an object is detected. These event messages will also trigger the outputs.
<div style="border: 1px solid black; padding: 5px;">  NOTE The first level in the list is of a lower level than the next levels. A higher level criterium can only be true when the lower level criterium (i.e. displayed at the top of the levels list) is also true. EXAMPLE Level 1: Number of objects = 3 Level 2: Length of the Queue = 5m In this case, a level 2 event will only be sent out when there are 3 object in a 5m queue. If the queue is longer than 5m but only contains 2 objects, no event will be sent out. If there are 3 objects in a 4m queue, only a level 1 event will be sent out. </div>		

Event type	Settings	Description
Count event Sends out events for each object that passes the filter criteria and/or integrated data, every period (in seconds) of the integration interval.	Delay time	The time (in seconds) between detection of an object and activation of the event. If the delay time is longer than the time during which the object should have been detected, the event will not occur anymore, e.g. delay time is 2 seconds but a vehicle is only in the zone for 1 second.
	Event name	Name of the event that will be sent out.
	Send events	Sends out event messages when an object is detected. These event messages will also trigger the outputs.
	Individual Data	Sends individual data messages per object. For more information, see the public API manual.
	Integrated Data	Sends integrated data messages. Integrated data is an average calculated over an integration interval. For each object, i.e. road user, that passes the filter criteria, the following data is sent out : <ul style="list-style-type: none"> • Occupancy (%), i.e. the percentage of the integration interval a point is occupied by an object. • Confidence, i.e. an indication of the accuracy of data (0–10 from bad to good). • Length of the object (0.1 m) • Headway, i.e. time between the back of an object and the back of the previous object (0.1 s). • Class, i.e. classification of the object, defined by the AI model. • Number of objects per class • Speed (km/h) • Gap time, i.e. time between the front of an object and the back of the previous object (0.1 s) • Density (number of objects/km), i.e. the average amount of objects per time interval, divided by the mean speed. For more information, see the public API manual.
	Integration Interval	The period (in seconds) over which data is integrated and data messages are sent out.
Instant Data	Sends instant data messages with each interval. The instant data message is a summary of all traffic, i.e. number of object in the zone, at the moment the data message is sent out. For more information, see the public API manual.	
Instant Data Interval	The period (in seconds) after which each instant data message is sent out.	

Event type	Settings	Description
	Application Name	Displays the application name in a separate column in the AI count table.
	Trajectory Id	Displays the trajectory id in a separate column in the AI count table.
	Trajectory Name	Displays the trajectory name in a separate column in the AI count table.
	Trajectory Description	Displays the trajectory relation between zones in a separate column in the AI count table.
	Last Class	Displays the class of the last detected object in a separate column in the AI count table.
	Last Speed	Displays the speed of the last detected object in a separate column in the AI count table.

21.1.2 Filter criteria

 NOTE
To display the filters, click <i>Customize Advanced Settings</i> .

The following table gives you an overview of the available filter criteria and settings.

Filter criteria	Settings	Description
Class	Person	Detects object of the enabled classes.  NOTE When you enable items, the switch is turned on, i.e. it shifts to the right and turns orange. When you disable items, the switch is turned off, i.e. shifts to the left and turns grey.
	Bicycle	
	Motorcycle	
	Car	
	Van	
	Small Truck	
	Large Truck	
	Bus	
	Car and Trailer	
	Van and Trailer	
Direction	Normal direction	Detects objects in the direction as indicated by the direction arrow in the zone.
	Opposite direction	Detects objects in the opposite direction of the direction arrow in the zone.
	Both directions	Detects objects in both directions of the direction arrow in the zone.
Speed	Minimum speed	Minimum speed (in km/h) an object needs to have to generate an event. Objects with a speed below this value will be filtered out and will not generate an event.
	Maximum speed	Maximum speed (in km/h) an object can have to generate an event. Objects with a speed above this value will be filtered out and will not generate an event.

Filter criteria	Settings	Description
Time	Minimum Time	Minimum time (in seconds) an object needs to be in the zone to generate an event. Objects that are in the zone for a shorter time than this value will be filtered out and will not generate an event.
	Maximum Time	Maximum time (in seconds) an object can be in the zone to generate an event. Objects that stay in the zone for a longer time than this value will be filtered out and will not generate an event.

21.2 Duplicating applications

Duplicating applications also copies all application settings.

1. Go to *AI Detection > Applications*.
2. To duplicate an application, select a previously added application and under *General*, click *Duplicate application*.



NOTE

You can duplicate applications until you have reached the maximum of 20 applications. When the maximum amount is reached, the button is disabled.

3. Adapt the *Application name* and *Event settings* and click *Customize advanced settings* to adapt the filter criteria as necessary.
See 21.1.1 *Event settings*, page 65 and 21.1.2 *Filter criteria*, page 68.
4. To save your configuration, click .

21.3 Removing applications

1. Go to *AI Detection > Applications*.
2. To remove an application, select a previously added application and under *General*, click *Remove application*.
3. To confirm you want to delete the application, click *Yes, I'm sure*.
4. To save your configuration, click .

Linking detection zones and trajectories to an application

After having created detection zones, trajectories and applications, you can now set up detection by linking the zones and trajectories to an application.



NOTE

- You can link 1 zone or trajectory to multiple applications.
- You can link 1 application to multiple zones and trajectories.

1. Go to *AI Detection > Setup Detection*.
2. In the top right corner, switch to the list or matrix view:
 - To set up detection in the list view, click .
 - a. Click .
 - b. In the *Link zone/trajectory to application* window, select a zone or trajectory and application.
 - c. Do one of the following:
 - To assign outputs to the application:
 - a. Click *Assign outputs*.
 - b. Click in the field to select the outputs for the event.
 - c. Click *Assign*.
 - d. Click *Finish*.
 - If you do not want to assign outputs to the application at this stage, click *Done*.

The zone/trajectory and application are added in the list.
 - d. To link other zones or trajectories to applications, repeat step a to c.
 - e. To unlink an application from a zone/trajectory, click in front of the application in that zone/trajectory.
 - f. To edit the assigned outputs, click .
 - g. To assign outputs when none are currently assigned, click the *Outputs* field next to the application.
 - Alternatively, to set up detection in the matrix view, click and select an application and zone/trajectory.
3. To save your configuration, click .

ThermiCam AI allows you to track each traffic object that enters the camera image. Tracking happens on the entire camera image without using zones and continues when the traffic objects stop moving. For each object passing through the camera image, the following information is stored and available via Public API:

- Position
- Speed
- Heading

1. Go to *AI Detection > Settings*.
2. To send out live track updates:
 - a. Under *Live Track Updates*, enable *Send Live Track Updates*.
 - b. Set the *Live Track Update Interval*.
 - c. Set the *Maximum Objects Per Message*.

For each Live Track Update Interval, 1 message will be sent out with the track data of all objects in the camera image. The number of objects in the message is limited to the Maximum Objects Per Message. If there are no objects in the camera image during the Live Track Update Interval, the message that is sent out will be empty.

3. To send out historical track data:
 - a. Under *Historical Track Data*, enable *Send Historical Track Data*.
 - b. Set the *Maximum Track Moments Per Object*.

With historical track data, any object that enters the camera image will be tracked until it leaves the camera image again, allowing you to recreate its entire trajectory. The first track moment is always when the object enters the image and the last track moment is when it leaves the image. The remainder of the maximum track moments are equally spread over the time the object was in the camera image. The historical track data messages are sent out per tracked object, at the end of the tracked object's lifetime.



NOTE

For more information on the track data messages and the track data types, access the Public API manual as follows:

1. Open a web browser.
2. In the address field, enter `<device_ip_address>/api` and press Enter.

**NOTE**

Traffic data collection with VA detection zones should only be used for backwards compatibility with older installations. For new installations, please use AI detection zones with the Counting group application. See 19 *AI detection zones*, page 61 and 21 *Applications*, page 65.

24.1 About traffic data

By default, ThermiCam AI collects integrated data. Integrated data is an average calculated over an integration interval and available per zone (lane). The data is available via the database, reporting and API.

The following table explains the various integrated data types.

Data type	Definition	Unit
Occupancy	Occupancy	%
Confidence level	Indication of the accuracy of data based on image quality	0 -10: from bad to good
Average length	Length of the vehicles	0,1 m / 3,94 in
Headway	Time between the back of a vehicle and the back of the previous vehicle	m
Density	Number of vehicles over distance	vehicles/km
Vehicle class	Classification of vehicles according to their length	-
Vehicle count	Number of vehicles	-
Speed	Vehicle speed	km/h
Gap time	Time between the front of a vehicle and the back of the previous vehicle	s (0,1 s)

The integrated data is then transferred from ThermiCam AI to:

- a PC, using dedicated PC tools.
- the FLIR Intelligent Transportation Systems management system (Flux) for storage in the database, making the data available to the Flux operator, e.g. to create data reports.
- Traficon Data Tool (TDT)
- higher level management software via the API.

24.2 About traffic data zones

Traffic data collection works with traffic data zones.

You can define up to 8 traffic data zones according to the following guidelines:

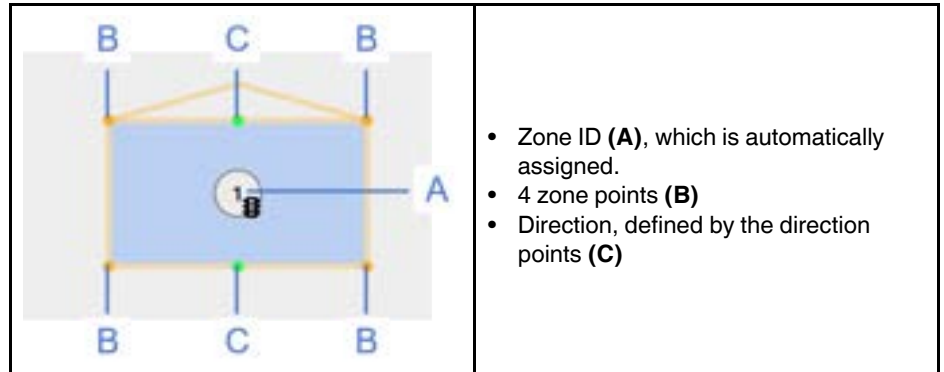

- The zone can have any length.
- The zone can be multiple lanes wide. However, to be able to differentiate counting in separate lanes, you should limit each zone to the width of one lane.
- The zone has a direction according to the normal direction of traffic.

As illustrated, each zone has the following characteristics:



24.3 Adding traffic data zones

1. Go to *VA Detection > Zones*.

2. To add a traffic data zone, click  and then .
3. Place and size the zone by dragging and dropping the zone points. Size the traffic data zone so that it is smaller than the traffic lane.
4. Set the direction of the zone by clicking one of the zone direction points.
5. To save your configuration, click .



Example of a traffic data zone



24.4 Isolating a traffic data zone

Isolation mode helps you to select and modify detection zones more easily.

1. Go to *VA Detection > Zones*.
2. Under the camera image, click *Isolate a zone* and select a zone.
3. To stop isolation, under the camera image, click the selected zone and select *Clear isolation*.
4. To save your configuration, click .



24.5 Deleting traffic data zones



1. Go to *VA Detection > Zones*.
2. Click the zone you want to delete.
If the zone is difficult to click because of overlapping zones, you can isolate a detection zone. See 19.5 *Isolating AI detection zones*, page 62.

3. Under the camera image, click .
4. To save your configuration, click .

24.6 Defining zone properties and characteristics



Zone properties and characteristics are used in the real-time event messages, event reports and event filters in Flux and allow you to distinguish the zones on different lanes.

1. Go to *VA Detection > Zones*.
2. In the camera image, click the zone.
3. Under the camera image, click .
4. Enter the *Zone name*.
5. Under *Zone characteristics*, click .
6. Fill in the *Characteristic* and *Value*.
7. To add other characteristics, repeat step 4 and 5.
You can define max. 16 characteristics.

8. To delete a characteristic, click .
9. To save your configuration, click .

24.7 Switching to the minimal user interface

By default, the user interface displays the zone ID for all zones. Switch to the minimal user interface if you do not want these to be displayed.

1. Go to *VA Detection > Zones*.
2. Under the camera image, click .
The zone ID is hidden for all zones.
3. To switch back to the full user interface, click  again.
The zone ID is displayed for all zones.
4. To save your configuration, click .

24.8 Changing the default data integration settings

The default data integration settings consist of the following parameters:

- Integration interval, i.e. the period of time (60 s by default) over which data is integrated
 - Integration type, i.e. the average over time (default) or over a distance
1. Go to *VA Detection > Settings* and switch to the *Traffic data* pane..
 2. Under *Traffic Data — Thermal*, adapt the following :
 - *Integration interval*
A smaller integration interval will result in more data to be stored in the management system.
Alternatively, to deactivate the integrated data function, select *Off*.
 - *Integration type*
For an average over time, set the value to *Time Average Integration type*.
For an average over distance, set the value to *Harmonic Average Integration type*.
 3. To save your configuration, click .

24.9 Counting road users

ThermiCam AI allows you to classify and count road users in maximum 8 classes:

- Person
- Bicycle
- Motorcycle
- Car
- Van
- Small truck
- Large truck
- Bus

1. Go to *VA Detection > Settings*.
2. Under *Event manager*, enable *Send Count Events*.
3. Under *Traffic Data > World tracker counting*, do one of the following:
 - Change the class ID of the road user as necessary.

 NOTE
Class 0 to 7 send out event class 1 to 8.

- To reduce the number of classes, assign the same class ID to multiple road users.
 - To disable counting of a particular road user, assign class ID -1.
4. To save your configuration, click .

24.10 Setting up the detection of overspeed

ThermiCam AI generates an overspeed event when the individual speed of a vehicle exceeds a set threshold.

1. Go to *VA Detection > Settings*.
2. Under *Traffic Data > Traffic Data — Thermal*, define the *Overspeed* (km/h).
3. To save your configuration, click .

24.11 Enabling individual data collection

1. Go to *VA Detection > Settings > .Traffic Data*.
2. Under *Event manager*, enable *Individual data*.
3. To save your configuration, click .

24.12 Disabling integrated data collection

1. Go to *VA Detection > Settings > .Traffic Data*.
2. Under *Event manager*, disable *Integrated data*.
3. To save your configuration, click .

**NOTE**

Flow monitoring with VA detection zones should only be used for backwards compatibility with older installations. For new installations, please use AI detection zones with the Queue Occupancy application. See 19 *AI detection zones*, page 61 and 21 *Applications*, page 65.

25.1 About flow monitoring

ThermiCam AI distinguishes between 5 levels of service that are defined by the flow speed and zone occupancy. The zone occupancy alarm level and the thresholds for dense, delayed and congested traffic are set by default, but you can change these settings per data zone.

ThermiCam AI generates an event for the levels of service 1 to 4. Flow monitoring events have an event activation and deactivation time to avoid fluctuation between levels of service when traffic is stabilizing again. You can configure the event (de)activation time per data zone. The event activation time is the time between detection of a changed level of service and activation of the event (default = 10 s). The deactivation time is the time that the level of service has returned to the previous level before deactivation of the event (default = 60 s).

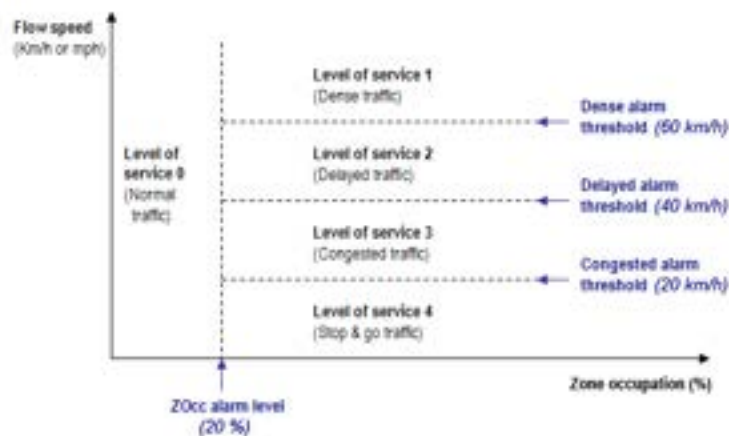

Figure 25.1 Levels of service defined by the flow speed and the zone occupancy, with their default settings

25.2 About flow data

ThermiCam AI collects flow data. The data is available via the database, reporting and API.

The following table explains the various flow data types.

Data type	Definition	Unit
Occupancy	Lane (zone) occupancy	%
Speed	Average vehicle speed based on buffered speed	km/h

The integrated data is then transferred from ThermiCam AI to:

- a PC, using dedicated PC tools.
- the FLIR Intelligent Transportation Systems management system (Flux) for storage in the database, making the data available to the Flux operator, e.g. to create data reports.
- Traficon Data Tool (TDT)
- higher level management software via the API.

25.3 Enabling flow monitoring

1. Go to *VA Detection > Settings > .Traffic Data*.
2. Under *Event manager*, enable *Send flow speed data*.
3. To save your configuration, click .

25.4 Changing the default flow data settings



1. Go to *VA Detection > Settings > .Traffic Data*.
2. Under *Event manager*, adapt the *Flow speed data send interval*.
The default time interval for transferring flow data to a PC is 60s by default.

A smaller integration interval will result in more data to be stored in the management system.

3. To save your configuration, click .

25.5 Changing the thresholds for flow monitoring

Use the zone occupancy and the thresholds for dense, delayed and congested traffic to define the various Levels of Service.

1. Go to *VA Detection > Zones*.
2. In the camera image, click the traffic data zone.
3. Under the camera image, click .
4. Do any of the following:
 - Type or select the *Zone occupancy* (0-99%).
 - Type or select the *Threshold for dense, delayed or congested traffic* (0-190 km/h).
5. To save your configuration, click .

25.6 Changing the event time on and time off

Use the event time on and off to avoid fluctuation between levels of service when traffic is stabilizing again.

1. Go to *VA Detection > Zones*.
2. In the camera image, click the traffic data zone.
3. Under the camera image, click .
4. Specify the following:

Parameter	Description
<i>Time on</i>	The time between detection of a changed level of service and activation of the event (default = 10 s, range : 1–300 s).
<i>Time off</i>	The time that the level of service has returned to the previous level before deactivation of the event (default = 60 s range : 1–300 s).

5. To save your configuration, click .

25.7 Setting the flow monitoring outputs

ThermiCam AI sends the Levels of Service via the speed event outputs.

For more information, see 27 *Detection outputs*, page 80.

**NOTE**

Masking zones apply to all detection and data zones.





26.1 About masking zones

With ThermiCam AI you can use up to 8 masking zones to avoid false detection in a detection or data zone or to make sure that some parts of the scene will not be tracked, limiting the track data to specific regions of interest.

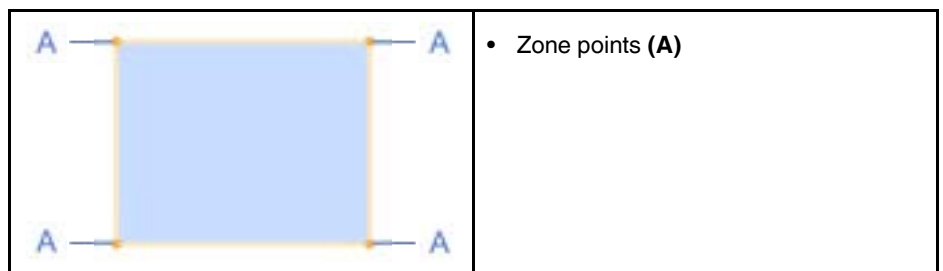
Objects in the masking zone will not be detected or tracked.



As illustrated, each zone has the following characteristics:

**26.2 Adding masking zones**

1. Go to *VA Detection > Zones*.
2. To add a masking zone, click  and then .
3. Place and size the zone by dragging and dropping the zone points.
To add an extra zone point, position the mouse on the border of the zone where you want to add the zone point until the cursor becomes a  and double click.
4. Shape the zone by adding additional zone points as necessary.
5. To save your configuration, click .

26.3 Duplicating masking zones

Duplicating a zone does not only copy the size and position of the selected zone, but also the zone settings.



1. Go to *VA Detection > Zones*.
2. Click the masking zone you want to duplicate.
If the zone is difficult to click because of overlapping zones, you can isolate a masking zone. See 26.4 *Isolating a masking zone*, page 78.
3. Under the camera image, click .
4. To save your configuration, click .

26.4 Isolating a masking zone

Isolation mode helps you to select and modify masking zones more easily.

1. Go to *VA Detection > Zones*.
2. Under the camera image, click *Isolate a zone* and select a zone.
3. To stop isolation, under the camera image, click the selected zone and select *Clear isolation*.
4. To save your configuration, click .

26.5 Deleting masking zones

1. Click the masking zone you want to delete.
If the zone is difficult to click because of overlapping zones, you can isolate a masking zone. See 26.4 *Isolating a masking zone*, page 78.
2. Under the camera image, click .
3. To save your configuration, click .

27.1 About the outputs

Instead of assigning the outputs when you link a zone to an application, you can also assign them all at once.

The *Outputs* page displays all active applications and their output assignment as well as the outputs for recall.

ThermiCam AI sends presence detection events via the detection outputs. The number of available detection outputs depends on the system architecture:

- BPL installation with TI BPL3 interface: up to 16 outputs
- PoE installation: 2 outputs (1 Normally Open, 1 Normally Closed) per FLIR PoE Interface.

27.2 Normal status of the detection outputs

Detection events are sent to the traffic controller via the interface. By default, the assigned outputs will close on detection events. Unassigned outputs are open. You can change the default settings for both assigned and unassigned outputs.

27.3 About the logical relation

(Logical relations only apply to the presence detection outputs.) When multiple presence detection zones are assigned to the same output, a logical relation (Boolean logic) applies:

- OR (default): (presence) detection on one of the zones assigned to the output will change the status of the output.
- AND: (presence) detection on all zones assigned to the output is required before the output changes status.

27.4 About the pulse events (off) time for counting

For each count, a pulse is sent to the outputs dedicated to counting for that zone. The length of this pulse is defined in the *Pulse Events Time*.

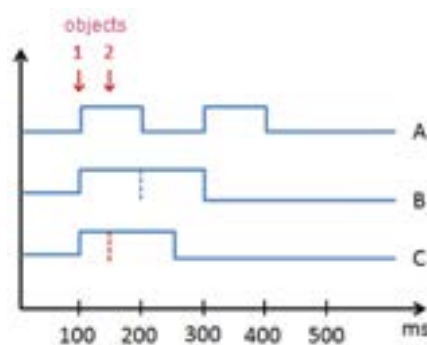

When multiple objects leave the zone at the same time, multiple pulses are sent. To be able to count these pulses via the outputs, there has to be a pause in the pulses. You can define this pause, i.e. the time between 2 simultaneous pulses, in the *Pulse Events Off Time*.



Pulse events time = 100 ms Situation

- A - Pulse events off time = 100 ms
When object 1 is detected, the first pulse is sent, followed by a pause of 100ms (the pulse events off time) and a second pulse for object 2. This situation allows you to use the outputs for counting.
- Situation B - Pulse events off time = 0 ms
When object 1 is detected, the first pulse is sent. The second pulse for object 2 follows immediately after the first pulse, without a pause.
- Situation C - Pulse events off time = -1 ms
When object 1 is detected, the first pulse is sent, as soon as object 2 is detected, the first pulse is ended and the second pulse is sent for object 2

27.5 Testing the outputs manually

1. Go to *Configuration > Outputs*.
2. Click *Test Mode*.
3. To start the test, click .
4. Test the outputs by clicking them.
5. To stop the test, click .

27.6 Configuring the detection outputs

The detection outputs allow you to change the normal output status and the assignment of the presence detection, traffic flow monitoring (speed) events, thermal quality recall (bad video) to one or multiple outputs.

1. Go to *Configuration > Outputs*.
2. Click an output.

Alternatively, to get an overview of all outputs and their assignment, click  to switch to the matrix view.



NOTE

None of the outputs on ThermiCam AI are assigned by default !

3. Do one of the following:

Goal	Action
To set the unassigned outputs to closed	Disable <i>Unassigned Outputs Open</i> .
To set the outputs to open on presence detection	Set <i>On event</i> to <i>Open</i>
To set the logical relation to AND (for presence detection outputs only)	Select <i>AND</i> as the <i>Logical relation</i> .
To enable <i>Pulse mode</i>	Select <i>Entry, Exit or Periodic</i> and change the <i>Pulse events (off) time</i> as necessary.
To assign the <i>Presence</i> detection outputs	Select the <i>Zone ID</i> and/or <i>Trajectory ID</i> checkboxes.
To assign thermal quality <i>Recall</i> to the outputs	Select the checkbox(es) for <i>Bad video</i> .
To assign <i>Speed event</i> outputs	Select or clear the <i>Level</i> checkboxes.
To assign <i>Overspeed</i> outputs	Select the <i>Zone ID</i> and/or <i>Trajectory ID</i> checkboxes.
To assign <i>Count Event</i> outputs	Select the <i>Class</i> checkboxes for each zone and/or trajectory.
To assign the <i>Bicycle Presence</i> detection outputs	Select the <i>Zone ID</i> and/or <i>Trajectory ID</i> checkboxes.
To assign the <i>Pedestrian Presence</i> detection outputs	Select the <i>Zone ID</i> and/or <i>Trajectory ID</i> checkboxes.
To assign the <i>Queue Occupancy</i> outputs	Select the <i>Level</i> checkboxes for each zone and/or trajectory.
To assign the <i>Wrong Way Driver</i> outputs	Select the <i>Zone ID</i> and/or <i>Trajectory ID</i> checkboxes.

4. To save your configuration, click .

28.1 Overriding the default settings for RYG phases

By default, the overlay in the camera image will show the RYG phases for the zones that are linked to the detection outputs. To show other RYG phases in the overlay, you can override the default settings.

1. Go to *VA Detection > Settings > RYG Phase Status*.
2. Turn *Override default settings* on.
By default all 16 phases are selected.
3. Disable the phases for which you do not want to display the RYG status in the overlay.
4. To save your configuration, click .

28.2 Configuring the overlay

Define what you want to display as overlay on the camera image or on the streaming video as follows:

1. Go to *Configuration > Display*.

Streaming video is on by default. To pause streaming video, click .

2. Under the camera image, click  and turn the following display items on or off as required :



NOTE

When you enable items, the switch is turned on, i.e. it shifts to the right and turns orange.
When you disable items, the switch is turned off, i.e. shifts to the left and turns grey.

- **General Settings**
Select whether the *Font* of the overlay should be displayed *Small*, *Medium* or *Large* or in *HD*.

Select whether the *Paint type* of the overlay should be *Transparent* or *Full*.

General	<i>Device name display</i>	Displays the name of the device as defined under <i>Administration > General > Settings</i>
	<i>Clock display</i>	Displays the date (MM/DD/YYYY) and time (hh:mm:ss tt, i.e. 12h format with AM/PM) as defined under <i>Administration > General > Time</i>
	<i>IP address display</i>	Displays the IP address as defined under <i>Configuration > Network > IP Settings</i> .
	<i>Version display</i>	Displays the firmware version of the Thermi-Cam AI device

- VA Algorithm Settings

General	<i>Thermal core ROI</i>	Displays the thermal region of interest, as defined in <i>Configuration > Camera</i>
	<i>Thermal quality display</i>	Displays the current thermal quality level
Vehicle presence data collection	<i>Flow Speed Data</i>	Displays the Zone Occupancy and Level of Service for each traffic data zone.
Traffic data collection	<i>Overspeed</i>	Displays "Overspeed" when a vehicle with overspeed is detected in the traffic data zone
	<i>Real-Time Traffic Data</i>	Displays the traffic data in real-time
	<i>Real-time traffic data class</i>	Displays the vehicle class in real-time
	<i>Real-time traffic data length</i>	Displays the vehicle length in real-time
	<i>Real-time traffic data level of service</i>	Displays the level of service in real-time
	<i>Real-time traffic data speed</i>	Displays the vehicle speed in real-time
	<i>Real-time traffic data width</i>	Displays the vehicle width in real-time
	<i>Traffic Data Area</i>	Displays the traffic data zones
	<i>Traffic data zone name</i>	Displays the name of the traffic data zone as defined in the Zone properties

- AI Algorithm Settings

AI detection	<i>AI Detection</i>	Displays the tracking of the object, i.e. location and speed.
	<i>AI Zones</i>	Displays the AI detection zones.
	<i>AI Zone Names</i>	Displays the name of the detection zone as defined in the Zone properties
	<i>AI Zone Ids</i>	Displays the zone ID of the detection zone.
	<i>AI Levels Table</i>	Displays the application, zone and Level of Service for each AI detection zone.
	<i>AI Count Table</i>	Displays the number of object per zone and trajectory in real-time.
	<i>AI Event Messages</i>	Displays the AI event as defined under Applications > Events

3. In the camera image, drag the orange text boxes to where you want to display the overlay.

4. To save your configuration, click .

 NOTE
The overlay is visible on the live view of the webpage, or on video stream 1. Video stream 2 cannot contain overlay.

ThermiCam AI has a recall function for thermal quality (i.e. bad video).

You can assign one or multiple outputs to the thermal quality recall function. See *27 Detection outputs*, page 80.

29.1 About time-out

The recall function is characterized by its time-out parameter. The time-out is an adjustable period of time that passes before the outputs assigned to recall will change status.

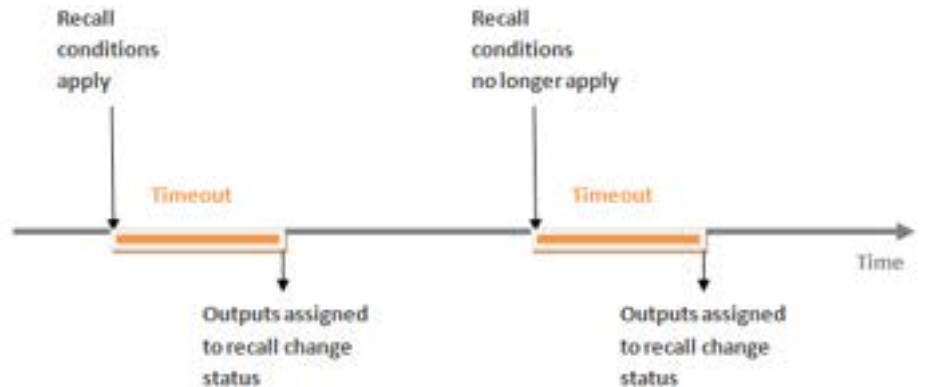

Figure 29.1 Recall time-out

29.2 Adapting the recall settings

ThermiCam AI goes into recall when the quality of the thermal image has dropped below a set threshold.

1. Go to *VA Detection > Settings* and switch to the *Thermal Quality* pane.
2. Change the *Threshold* (Default 20), *Time on* (Default 2) and *Time off* (default 2) as necessary.



NOTE

- With a higher threshold, the system is more sensitive to the deterioration of the thermal image.
- When the threshold is set to 0, thermal quality recall is disabled and no events are created.

3. To reset the thermal quality algorithm, e.g. when the ThermiCam AI device is moved from its installation position, click *Reset Thermal Quality*.

4. To save your configuration, click .

29.3 Assigning thermal quality recall or detection quality recall to one or multiple outputs



NOTE

By default, recall is NOT activated on output level.

For more information, see *27 Detection outputs*, page 80.

Working with existing configurations and offline networks

30.1 About sending configurations

The configuration file contains all settings that determine the operation of the ThermiCam AI device or the TI BPL3 interface.

After setup or with each change you make, you must send the configuration to ThermiCam AI or to the interface to make it operational by clicking .

30.2 About offline networks

An offline network is a copy of the ThermiCam AI network created in the web interface. The offline network is saved as a compressed network file. The file may serve as a backup, or can be used to prepare the configuration offline. The offline configuration of selected devices can be loaded again. You can also use offline networks to manage multiple configurations for a device.

30.3 Exporting and importing a configuration or offline network

1. Go to *Administration > General*.
2. Switch to the *Import/Export* pane.
3. Do one of the following:
 - To download a configuration, select *Configuration* and click *Download*.
 - To upload a configuration, select *Configuration* and click *Upload*.
 - To download an offline network, select *Offline Network* and click *Download*.
 - To upload an offline network, select *Offline Network*, click *Upload*, select the offline network, click *Send* and then *Reload*.



NOTE

Offline networks can only be downloaded and uploaded on TI BPL3 , not on ThermiCam AI.

4. To save your configuration, click .

30.4 Restarting ThermiCam AI with the current or factory default configuration

1. Go to *Administration > General*.
2. Under *Settings*, do one of the following:
 - To return to the configuration that was last saved, click *Reload Configuration*.
 - To reset the configuration to the default values, click *Reset to Default* and click  to send the changes to the camera.
All settings will be reset to factory default, except for the network settings, users settings and passwords.
 - To reset the configuration for all users, click *Reset all users*.
 - To restart ThermiCam AI with the current configuration, click *Reboot*.

Communication protocol: public API

31.1 About the Public API manual

To integrate your ThermiCam AI into your own software, please refer to the FLIR ITS Public API Manual.

The API is a REST API combined with WebSockets for subscriptions. The protocol uses basic HTTP GET and POST for communication.

31.2 Accessing the Public API manual

1. Open a web browser.
2. In the address field, enter `<device_ip_address>/api` and press Enter.

31.3 General functionality

The following messages are general for all FLIR ITS devices:

URL	Purpose
<code><device_ip_address>/api/device/info</code>	To retrieve information from the device itself, such as company name, device name, product type, firmware version.
<code><device_ip_address>/api/device/time</code>	To get and send the current time from and to the device.
<code><device_ip_address>/api/device/uptime</code>	To know how long the device has been running.
<code><device_ip_address>/api/image/current</code>	To retrieve the current (static) image from the device.
<code><device_ip_address>/api/image/event/:eventNumber</code>	To retrieve an image for a certain event.
<code><device_ip_address>/api/subscriptions</code>	To (un)subscribe to events and data.

For more information about these general messages, please refer to the FLIR ITS Public API Manual.

31.4 Supported events types

Events are notifications about certain traffic or technical situations that have been detected by the device.

To get an overview of the event types supported by the device, enter the following in the address field of the web browser:

`<device_ip_address>/api/events/supported`

ThermiCam AI supports the following event types:

- Bicycle Count
- Bicycle Presence
- Loop
- Overspeed
- Pedestrian Count
- Pedestrian Occupancy
- Pedestrian Presence
- Presence
- Presence Level
- Queue Occupancy
- Bad Presence Quality
- Bad Video
- Speed Alarm
- Vehicle Count
- Configuration
- Firmware Update

For more information about these event types, please refer to the FLIR ITS Public API Manual.

31.5 Supported data types

Data is a periodical message about the detected traffic conditions. It can include things like number of vehicles, average speed, etc.

To get an overview of the traffic data types supported by the device, enter the following in the address field of the web browser:

`<device_ip_address>/api/data/supported`

ThermiCam AI supports the following data types:

- Integrated Data
- Individual Data
- Flow Speed Data
- Presence Data
- Bicycle Data
- Pedestrian Data
- Pedestrian Occupancy Data
- Pedestrian Presence Tracking
- Pedestrian Zone Counting Data
- Queue Occupancy Data
- Track Data
- Track Update
- Individual Data AI
- Interval Data AI
- Integrated Data AI
- Instant Data AI

For more information about these data types, please refer to the FLIR ITS Public API Manual.



NOTE

ThermiCam AI allows you to store 32 MB of track data.

With the default setting of 20 track moments, you can store a maximum number of around 28000 objects. With an average number of 10 detected object per minute, the maximum track history that can be stored is 2800 minutes or 47,5 hours. To extend the history, you can lower the number of track moments.

Note that the track data is stored in the RAM and will be lost in case of a reboot.

Data transfer from ThermiCam AI to a PC using Traficon Data Tool

32.1 Data storage on ThermiCam AI

ThermiCam AI can store data up to one month, taking into account the following configuration:

- 4 traffic data collection zones, with events and traffic data enabled
- 16 presence detection zones with presence data enabled
- 3 vehicle classes
- 5-minute integration interval

Alternatively, ThermiCam AI can also store bike data up to one month, taking into account the following configuration:

- 4 zones
- 3-minute interval

ThermiCam AI also stores track data which is accessible via Public API. For more information, see 31.5 *Supported data types*, page 87.

32.2 About Traficon Data Tool

The Traficon Data Tool allows you to download or monitor data and events generated on FLIR devices on your network and view them in xml or Excel format.

32.3 Installing and starting Traficon Data Tool

Traficon Data Tool is available from the installation CD delivered with the FLIR devices.

1. Insert the Traficon Data Tool installation CD in the CD-ROM drive.
2. Go to the installation of Traficon Data Tool.
3. Follow the instructions provided by the installation wizard.
4. To complete the installation, click *Finish*.
5. To start Traficon Data Tool, choose *Start > All programs > Traficon Data Tool > Traficon Data Tool*.

32.4 Main window

As illustrated below, the main window of the Traficon Data Tool will guide you through the various steps for downloading or monitoring the data and events. Click a step to jump to the procedure described in the next chapter.

1. Defining the download settings.
2. Finding the devices.
3. Defining where to store the downloaded files.
4. Selecting the devices.
5. Downloading the data and events history.
6. Downloading data and events in a particular time frame.

7. Monitoring data and events in real time.

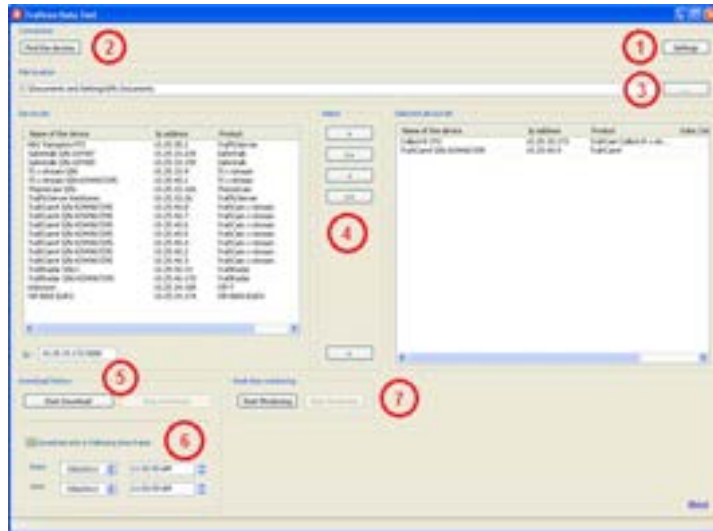

32.5 Working with Traficon Data Tool

32.5.1 Defining the download settings

In the Download settings, you can define a broadcast and connection timeout, whether to download events and/or data and what system of units will be used when converting this raw xml data to Excel.

1. Under *Connection*, click *Settings*.
The Settings dialog is displayed.

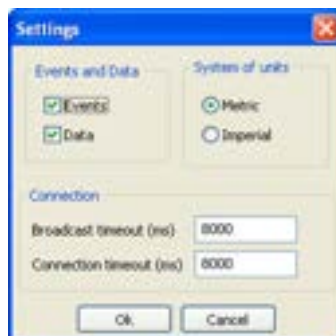

2. To download *Events* and/or *Data*, select the relevant checkbox(es).
3. Select the *System of units* you want to use when data is displayed in Excel.
4. Define the *Broadcast timeout*, i.e. the time Traficon Data Tool will wait for an answer when scanning the network for devices.
If there are a lot of different devices on the network or poor connection quality, we advise to increase the broadcast timeout.
5. Define the *Connection timeout*, i.e. the time Traficon Data Tool will wait for an answer during all other communication with the devices.
6. To save the settings, click *OK*.

32.5.2 Finding the devices

To scan the network for devices, under *Connection*, click *Find the devices*.

Traficon Data Tool searches for all devices on the network and displays them in the *Device list*.

The devices are sorted according to their name.

32.5.3 Defining where to store the downloaded files

1. Under *File location*, click ...
The *Browse for folder* dialog is displayed.
2. Select the folder to download the data to.
Alternatively, to create a new folder, click *Make new folder*.

When downloading the data, Traficon Data Tool will create a subfolder per device, according to the following syntax `<name>_<IP address>_<Port>`
3. Click *OK*.

32.5.4 Selecting the devices

You can select devices by moving them to the *Selected device* list.

- To add devices to the *Selected device list*, do one of the following:
 - Select 1 or more (using Shift or Ctrl) devices in the *Device list* and click *>*.
 - To add all devices to the *Selected device list*, click *>>*.
- To remove devices from the *Selected device list*, do one of the following:
 - Select 1 or more (using Shift or Ctrl) devices in the *Selected device list* and click *<*.
 - To remove all devices from the *Selected device list*, click *<<*.
- To be able to collect data from devices behind a router, enter the IP address and port (`<IP>:<port>`) of these devices and click *>*.

32.5.5 Downloading the data and events history

1. To start downloading the data and events history, click *Start download*.
If this is the first history download, Traficon Data Tool will start downloading from the oldest line in the database onwards.

If this is not the first history download, Traficon Data Tool will start where the previous download was stopped.
2. To stop downloading the data and events history, click *Stop download*.
The download files (in xml and Excel/csv format) are saved in the predefined folder (see 32.5.3 *Defining where to store the downloaded files*, page 90) and the downloaded data is deleted from the database on the device.

32.5.6 Downloading data and events in a particular time frame

Use this function if you want to download data and events from a particular period, e.g. in case of a communication error between the detection module and FLUX, caused by a third party while e.g. working on a traffic pole.

1. Select *Download only in the following time frame*.
2. Enter a start date and time for downloading the data and events.
3. Enter an end date and time for downloading the data and events.
4. To start downloading the data and events for the selected time frame, click *Start download*.
The download files (in xml and MS Excel/csv format) are saved in the predefined folder (see 32.5.3 *Defining where to store the downloaded files*, page 90) and the downloaded data is deleted from the database.

32.5.7 Monitoring data and events in real time

1. To start monitoring the data and events in real-time, click *Start monitoring*.
From this moment onwards, Traficon Data Tool will save all new incoming data and/or events (as defined in the download settings) in xml and Excel/csv format in the predefined folder (see 32.5.1 *Defining the download settings*, page 89 and 32.5.3 *Defining where to store the downloaded files*, page 90).
2. To stop monitoring the data and events in real-time, click *Stop monitoring*.

32.5.8 Converting a .csv file to an .xls file via MS Excel

1. Open MS Excel.
2. In the *Data* tab, in the *Get External Data* group, click *From Text*.

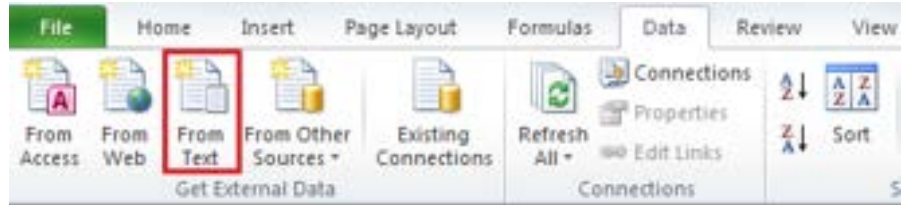

3. Double click the .csv file you want to import.
4. Follow the instructions in the *Text Import Wizard*:
 - a. In step 1, set the original data type to *Delimited* and click *Next*.
 - b. In step 2, under *Delimiters*, clear *Tab* and select *Comma* and click *Finish*.
5. Select where you want to put the data and click *OK*.
6. Save the resulting file as an .xls file.

Date	Time	Lane	BicycleCount (#bicycle)
14/04/2009	18:00:00	1	2
14/04/2009	18:00:00	2	3
14/04/2009	18:01:00	1	3
14/04/2009	18:01:00	2	3
14/04/2009	18:02:00	1	3
14/04/2009	18:02:00	2	5
14/04/2009	18:03:00	1	0
14/04/2009	18:03:00	2	0
14/04/2009	18:04:00	1	2
14/04/2009	18:04:00	2	1

Figure 32.1 Example of an .xls file with integrated bicycle data from 2 lanes, the integration interval is 60 s.

33.1 About streaming video

ThermiCam AI uses MJPEG, H264 or H265 compression technology to provide real-time streaming video over the network.

The bit rate and frame rate have default settings (Bit rate is set to 2 Mbit/s and frame rate is set to 29.97 fps) but are configurable.

You can view streaming video via web interface or any video player accepting rtsp stream, e.g. VLC Media Player.

The streaming video is ONVIF¹ Profile S conformant.

33.2 Changing the default video settings

1. Go to *Configuration > Video > Video Compression*.
2. Define a *Stream name*.
3. Select the *Codec* (MJPEG, H264, H265).
4. Define the *Bit rate Control*, the *CBR Bit Rate*, the *Vbr Minimum Bit Rate* and the *Vbr Maximum Bit Rate* (range: 0,01 to 8 Mbit/s, default 2).
5. Define the *Frame rate* (1 to 30 fps, default 29,97).
6. Define the *Gop Length* (1 to 254 frames, default 30).
7. Select a *Profile* (Main or High)
8. To use multicast, turn on *Multicast* and fill in the following fields:
 - *Multicast port* (default 46454)
 - *Multicast group*, i.e. the IP address (in the 239.x.y.z range) used for multicast.
 - *Multicast TTL* (Time To Live) : This indicates how long the data should be sent, i.e. the number of routers the data is allowed to pass:
 - 0: restricted to the same host. The data will not be sent by any interface.
 - 1-255: the number of routers (hops) the video stream is allowed to pass.



NOTE

Multicast is not supported for BPL.

9. Alternatively, to use unicast, clear *Multicast*.
10. To save your configuration, click .

33.3 Viewing streaming video via the web interface

The *Live View* page displays live video from ThermiCam AI.

As illustrated below, the Live View page allows you to:

- Pause or play the live video
- Display the status of the outputs to verify detection
 - Orange: Output is triggered by detection.
 - Blue: Output is assigned but not triggered by detection.
 - Grey: Output is not triggered.



NOTE

When detection zones and outputs are not configured, the status of the outputs will remain unchanged.

1. ONVIF is a trademark of ONVIF, Inc.

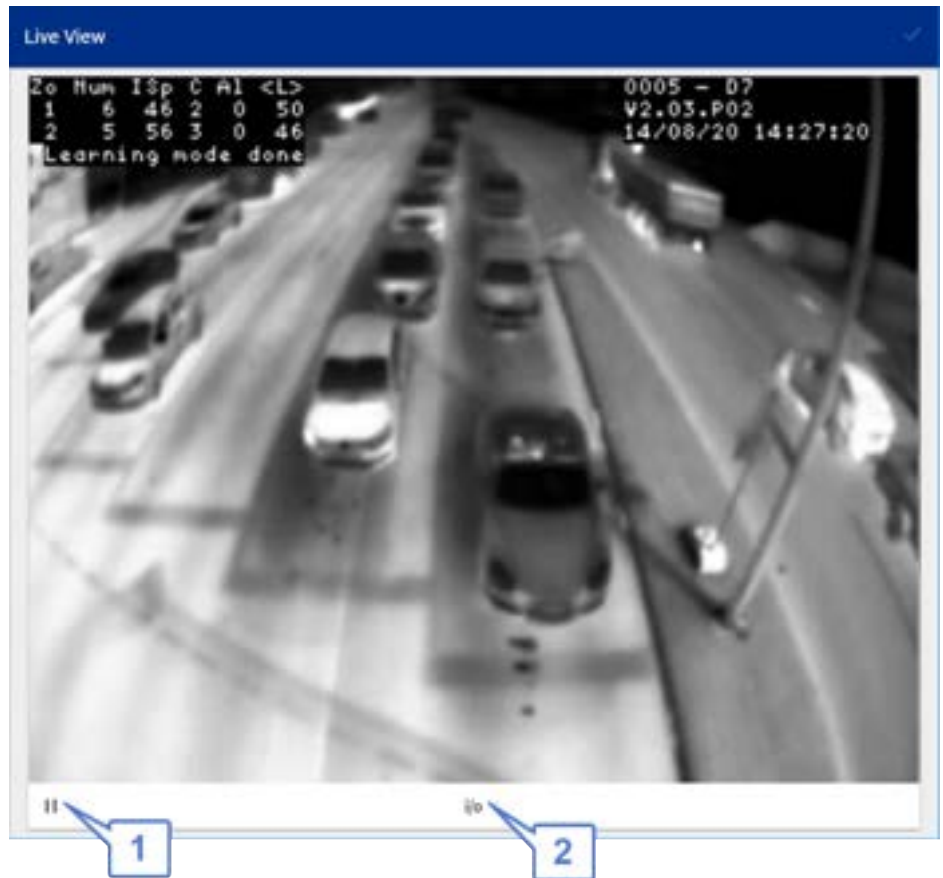

Figure 33.1 Live View page

1. Pause/Play the live view
2. Display the status of the outputs

33.4 Viewing and recording streaming video via VLC media player

33.4.1 About VLC media player

VLC media player is a third-party software, free of charge, to view streaming video from any PC connected to the ThermiCam AI network. Via this software, you can also record streaming video and view recordings.

VLC media player is available on the Web. The instructions below apply to VLC Media Player V2.0.0. FLIR Intelligent Transportation Systems cannot guarantee that these instructions will also work on other versions of VLC Media Player.

33.4.2 To view streaming video via VLC media player

1. Choose *Media > Open Network Stream*.
2. Set the *Protocol* to *RTSP*.

3. Enter the IP Address of ThermiCam AI.

- To show video encoder 1, enter the default “rtsp://<IP address>” or “rtsp://<IP address>/?video=1”.
If RTSP user authentication is enabled, use URL “rtsp://Username:Password@<IP address>/?video=1”.

The default “rtsp://<IP address>” also shows video encoder 1.

By default, this video stream contains overlay but is configurable.

**NOTE**

To view streaming video via the TI BPL3 interface, add the RTSP port as defined in the interface setup under *Configuration > Network > Managed devices > Connected devices*, i.e. “rtsp://<IP address of the interface>:<rtsp port of the connected device>”

- To show video encoder 2, enter “rtsp://<IP address>/?video=2”.
If RTSP user authentication is enabled, use URL “rtsp://Username:Password@<IP address>/?video=2”.

This video stream does not contain overlay.

For more information on RTSP user authentication, see 34.3 *User authentication*, page 97.

4. Click *Play*.**33.4.3 To record streaming video via VLC media player**

- Choose *Media > Streaming*.
- Click the *Network* tab.
- Set the *Protocol* to *RTSP*.
- Enter the *IP Address* of ThermiCam AI.

- To record video encoder 1, enter the default “rtsp://<IP address>” or “rtsp://<IP address>/?video=1”
If RTSP user authentication is enabled, use URL “rtsp://Username:Password@<IP address>/?video=1”.

The default “rtsp://<IP address>” also shows video encoder 1.

By default, this video stream contains overlay but is configurable.

- To record video encoder 2, enter “rtsp://<IP address>/?video=2”.
If RTSP user authentication is enabled, use URL “rtsp://Username:Password@<IP address>/?video=2”.

This video stream does not contain overlay.

For more information on RTSP user authentication, see 34.3 *User authentication*, page 97.

- Click *Stream*.
- Click *Next*.
- Under *Destinations*:
 - Click *Add*.
 - Click *Browse* and enter the *File name* with extension **.mpg** (e.g. Recording_C1.mpg).
 - Click *Save*.
- Under *Transcoder Options*:
 - Set the *Profile* to *Video - MPEG-4 + AAC (MP4)*.
 - Click the *Edit Selected Profile* button .
 - In the *Encapsulation* tab, select *MPEG-TS*.
 - In the *Video Codec* tab, set *Codec* to *MPEG-4*.

- e. Click *Save*.
- 9. Click *Stream*.
- 10. If required, provide a user name and password.
- 11. To stop the recording, click the *Stop playback* icon .
To view a recording via VLC media player, double-click the recorded file.

33.5 Viewing streaming video via ONVIF Profile S

ThermiCam AI is ONVIF Profile S conformant. Connect with default user “admin” and Password ‘admin”.

34.1 About product security

By default, ThermiCam AI is not secured to ensure compatibility with other existing systems.

Take the following steps for basic product security :

1. Disable unsecure services as necessary. See 34.2 *Enabling or disabling services*, page 96.
2. Enable user authentication and change the default password. See 34.3 *User authentication*, page 97.
3. Adapt the wifi password. See 13.2 *Adapting the Wi-Fi settings*, page 52.



NOTE

With product security enabled, you can access the device by using the default user name 'admin' and password 'admin'.

34.2 Enabling or disabling services

The Services page gives you an overview of what is accessible from outside the product. By default, all services are enabled.

1. Go to *Administration > Product security*.
2. In the *Services* page, select the services you want to enable and clear the services you want to disable:
 - XML2 (unsecure) vs. XML2 over TLS (secure).
Used for communication with external software such as Cascade. Over TLS, communication is encrypted and not readable for others.
 - HTTP (unsecure) / HTTPS (secure)
Used for public API and video streaming via VLC.
 - SNMP
Simple Network Management Protocol. Used to monitor services and to request/collect information from a device (e.g. version number, status, etc).



NOTE

SNMP is only available when ThermiCam AI is used with TI BPL3.

- ONVIF (unsecure)
Open Network Video Interface Forum, a standard for collaboration of network video devices such as HD IP cameras and IP camera software. Used by network tools to find devices and request information from them.



NOTE

ONVIF is only available when ThermiCam AI is used with ETH.

- RTSP Video streaming (unsecure)
Used for video streaming via other tools.
- XML2 discovery (secure)
Used to scan network.



NOTE

Disabling a parent item will also disable the underlying items.

3. To save your configuration, click .

34.3 User authentication

To limit access to device and its video streams, you can enable user authentication. Only users defined under *Administration > Users* will be able to logon to the device.

 NOTE
Unless otherwise defined under <i>Administration > Users</i> the default user name and password is 'admin'.

1. Go to *Administration > Product security*.
2. Switch to the *User Authentication* pane.
3. Do one of the following:
 - To enable user authentication on the video stream, select *RTSP*.
 - To enable user authentication on the entire device, select *Authentication*.
 - To hash the user name and password instead of sending it as clear text, select *Digest*.

 NOTE
To make user authentication fully secure, go to <i>Administration > Product security > Services</i> and enable SSL encryption by selecting <i>HTTPS (secure)</i>

4. To save your configuration, click .

34.4 Physical access

Depending on your product, select the physical access that is required. By default, all ports are enabled.

1. Go to *Administration > Product security*.
2. Switch to the *Physical Access* pane.
3. Do one of the following :
 - Clear the ports you do not need to disable them.
 - Select the ports you need to enable them.

 NOTE
Disabling a parent item will also disable the underlying items.

 CAUTION
When restricting physical access to the product (by disabling services), make sure you do not lock yourself out !

4. To save your configuration, click .

34.5 Certificates

34.5.1 Self-signed vs. CA-signed certificates

A device generates a certificate that describes its identity. The unique identifier on Ther-miCam AI is its IP address. This certificate is only valid for this specific IP address. The device also generates a private key that it uses to sign the certificate. This results in a self-signed certificate. Self-signed certificates are not trusted by browsers, there is no way to verify that the device is who it claims to be.

As a solution, CA-signed certificates are generated and signed by a CA (Certificate Authority), i.e. an organization that is "trusted". On the public internet, there are several CA's that are trusted by all major browsers. In a private network, the company that owns the network can be its own CA.

34.5.2 Implementing certificates for ThermiCam AI

By default, our products use self-signed certificates. This means that the communication is encrypted, but the browsers cannot trust the device. For trusted certificates, you should first generate a CA certificate and CA private key for your organization and use this CA certificate to sign a device certificate.

This can be done in 2 ways:

- Set certificate
- Sign certificate

34.5.2.1 Set certificate

 NOTE
Before setting the certificate, make sure to obtain the certificate from the network provider.

1. Generate the device (also called 'end-entity') certificate and private key. The certificate should contain at least the device's current IP address.

 NOTE
The certificate is only valid for this specific IP address.

2. Sign the device certificate with your CA certificate and CA private key.
3. Go to *Administration > Product security*.
4. Switch to the *Certificates* pane.
5. Under *Set certificate*, do the following:
 - a. To upload the signed device certificate, click *Select Certificate* and locate it.
 - b. To upload the device private key, click *Select Private Key* and locate it.
 - c. Click *Send*.

34.5.2.2 Sign certificate

1. Go to *Administration > Product security*.
2. Switch to the *Certificates* pane.
3. Under *Sign certificate*, do the following:
 - a. To upload your CA certificate to the device, click *Select Certificate* and locate it.
 - b. To upload your CA private key to the device, click *Select Private Key* and locate it.

 NOTE
The certificate is only valid for the current IP address.

- c. To save the CA private key on the device, select *Save CA private key*. In case the device's IP address changes, the device will re-generate and re-sign its own certificate to be valid. This is option is not safe but can be useful for smaller setups.
- d. Click *Send*.

The device will sign its own certificate with the provided CA certificate and CA private key. If the device is an interface, all connected devices will also be signed.

34.6 EAPOL

Enable EAPOL to help prevent unauthorized access and ensure that the communication between the client and the authentication server is secure.

1. Go to *Administration > Product security*.
2. Switch to the *EAPOL* pane and turn on *Enabled*.
3. Define a *Username* and *Private key password*.
4. Generate a private key and CA certificate using open SSL.
5. Click *Select private key* and locate and select the private key on your computer.

6. Click *Select CA certificate* and locate and select the CA certificate on your computer.
7. Create a certificate signing request (CSR) and send it to a Certificate Authority (CA) for signing. The CA returns a signed client certificate.
8. Click *Select Client certificate* and locate and select the client certificate on your computer.
9. Click *Send*.

34.7 Exporting the physical access log

The physical access log gives you an overview of when the various ports were enabled or disabled and when there was a connection to or a disconnection from these ports . You can export the log as follows:

1. Go to *Administration > Product security*.
2. Switch to the *Physical Access Log* pane.
3. Click *Export All*.
The physical access log is downloaded as a .csv file.

34.8 Exporting the user log

The user log gives you an overview of the users that logged in or out on the device:

1. Go to *Administration > Product security*.
2. Switch to the *User Log* pane.
3. Click *Export All*.
The user log is downloaded as a .csv file.

Maintenance and troubleshooting

35.1 Periodic maintenance

FLIR Intelligent Transportation Systems recommends performing the following maintenance tasks once per year. Depending on the on-site conditions, you may need to increase the frequency of maintenance.

Maintenance task	Tools required	Note
Clean the faceplate of ThermiCam AI	Soft cotton cloth dampened with fresh water. Do not use abrasive materials, such as paper or scrub brushes as this will possible scratch and damage the lens. Only wipe the lens clean when you visually see contamination on the surface. FLIR Intelligent Transportation Systems recommends using Isopropyl alcohol (isopropanol, IPA) to clean the lens.	Avoid moving the device.
<ul style="list-style-type: none"> • Check the camera image • Verify the configuration of the system • Save a backup of the system (offline network) 	PC with web browser	For guidance, consult the user guide.

35.2 Firmware upgrade of ThermiCam AI

 NOTE
When ThermiCam AI is connected to an interface, update the firmware via the interface.

1. Go to *Administration > Firmware*.
2. Click *Select Firmware*, locate and select the new firmware file and click *Open*.
3. Click *Upgrade*.
The firmware is uploaded and the device is programmed and rebooted.
4. When the device was upgraded successfully, refresh the ThermiCam AI web page by clicking *Reload*.

35.3 Technical Event log

The technical event log gives you an overview of all the technical events that occurred on ThermiCam AI. The Technical Event Log page allows you to sort, filter, reload, export and clear the event log.

1. Go to *Administration > Technical Event Log*.

2. In the Technical Event Log page, do one of the following:

- To sort the technical event log, click a column: *Device*, *Event Type*, *State*, *Timestamp*.
Click once to sort in ascending order, click twice for descending order.
- To filter the event log:
 - a. Click *Show Filter*.
 - b. Under *Device*, clear the check boxes of the devices for which you do not want to see the technical events.
Alternatively, to show all devices again, click *Reset Filter*.



NOTE

You can only select a device when ThermiCam AI is used with TI BPL3 .

- c. Under *Level*, clear the check boxes of the event types you do not want to see.
Alternatively, to show all event types again, click *Reset Filter*.
 - d. To close the filter, click *Hide filter*.
- To load the latest version of the event log, click *Reload*.
 - To export the entire event log as a .csv file, click *Export All*.
 - To delete all entries from the technical event log, click *Reset event log*.

35.4 System log

You can download the system log file and send it to FLIR Intelligent Transportation Systems for evaluation:

1. Go to *Administration > System Log*.
2. Do one of the following:
 - To download the system log, click *Download System Log*.
The system log is downloaded as a .csv file.
 - To delete all entries from the system log, click *Reset system log*.

35.5 Replacing a ThermiCam AI device

Replacing a ThermiCam AI device consists of the following tasks:

1. Uninstalling the broken device
2. Installing the replacement device
3. Making the replacement device operational.

For details on the installation tasks, see 7 *Installation procedure*, page 24.

35.5.1 To uninstall the broken ThermiCam AI device

1. Turn off the power.
2. To remove the mounting bracket (and ThermiCam AI) from the pole, cut the stainless steel retaining straps or unscrew the stainless steel bolts.
3. Remove the connector with cable from ThermiCam AI.



NOTE

Do not open the ThermiCam AI device. Warranty is no longer valid once the device has been opened.

35.5.2 To install the replacement ThermiCam AI device

1. Mount the replacement device.
Try to position the replacement device in the same way as the broken device was positioned so that the replacement device covers the same area.
2. Reconnect the connector with cable.

3. Turn the power on.

35.5.3 To make the replacement device operational



Connect to the replacement device and send the configuration of the broken device to the replacement device. In addition, double-check the configuration: the replacement device may have a slightly different camera position, so you may need to reposition the presence detection zones. For BPL installation, you also need to verify the error outputs assigned to the replacement device.

The configuration of the broken device is available via the system backup (offline network).

1. Connect the PC to the ThermiCam AI network and open the web interface of the replacement device.
See 11 *ThermiCam AI web interface*, page 48.
2. For BPL installation, in the web interface of TI BPL3, go to *Configuration > Network > BPL* and click *Apply* to adapt the *Channel*.
3. To send the configuration of the broken device to the replacement device:
 - a. Go to *Administration > General > Import/Export*.
 - b. Select *Offline Network* and click *Upload*.
 - c. Select the offline network and click *Open*.
 - d. Click *Send*.
 - e. Click *Reload*.
4. To verify the error output of the replacement device:

 NOTE
Error outputs are only available in BPL installation.

- a. Open the web interface of TI BPL3.
- b. Go to *Configuration > Error Outputs*.
- c. Verify and reassign the error outputs if required.
- d. To save your configuration, click .

 NOTE
To reposition the presence detection zones:
<ol style="list-style-type: none"> 1. Open the web interface of the replacement device. 2. On the camera image, verify the position of the presence detection zones and reposition them if required.
3. To save your configuration, click  .

35.6 Replacing a TI BPL3 device (BPL only)

Replacing a TI BPL3 device comprises the following tasks:

1. Uninstall the broken device
2. Install the replacement device
3. Configure the replacement device.

For details on the installation tasks, see 7 *Installation procedure*, page 24.

35.6.1 To uninstall the broken TI BPL3 device

1. Disconnect TI BPL3 from the network.
2. Loosen the screws and take the device out of the rack.
3. Remove all connectors from the backplane of TI BPL3.

35.6.2 To install the replacement TI BPL3 device

1. Put back all connectors on the backplane of the replacement device.
2. Mount the TI BPL3 device.
3. Connect TI BPL3 to the network.

35.6.3 To make the replacement device operational

Assign the IP address of the broken device to the replacement device.

1. Connect the PC to the ThermiCam AI network and open the web interface of the replacement device.
See 11 *ThermiCam AI web interface*, page 48.
2. If more than one interface is used, go to *Configuration > Network > BPL* and adapt the *Channel* as necessary.
3. Define the device name.
See 12 *General settings*, page 49.
4. Assign the error outputs.
See 10.4 *Error outputs*, page 44.

35.7 Replacing the fuses of a TI BPL3 EURO

1. Make sure the power supply is switched OFF.
2. Remove the TI BPL3 interface from the rack or DIN rail.
3. Remove the 2 screws at the left hand side of the frontplate of the TI BPL3 interface.



4. Gently slide the PCB out of the housing.



5. Locate the fuses on the PCB.



6. Use an Ohm meter to check which fuse is blown.
7. Use a screwdriver to lift the blown fuse out of the fuse holder.



8. Insert a new fuse by clicking it in the fuse holder.

**NOTE**

Fuse specifications:

- Voltage rating : 250VAC
- Current rating : 4A
- Breaking current : 1000A
- Time delay : FF
- Approved fuses
 - Littelfuse 2301400043 / 2301400002 / 2301400000
 - Shurter 0034.0907
 - SIBA 70 007 40.4 / 7000140.4

9. Slide the PCB back into the housing.
Make sure the housing is aligned with the groove on the back of the front plate so there is no gap between front plate and housing.

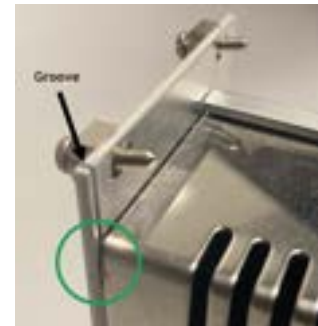
**Incorrect****Correct**

10. Re-attach the front plate of TI BPL3 to the housing using the 2 screws.
11. Switch ON the power supply.

Appendix: ThermiCam AI dimensions

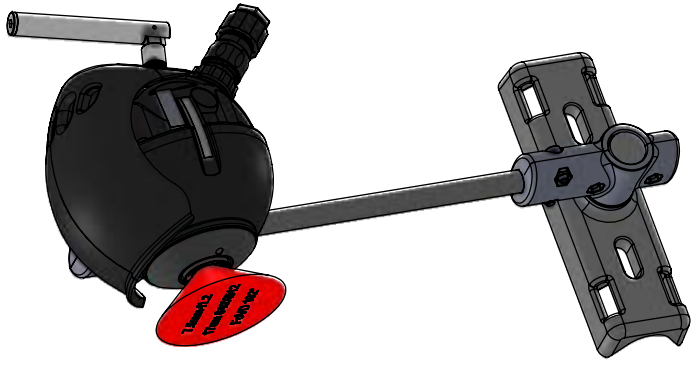

Antenna, can turn 90°

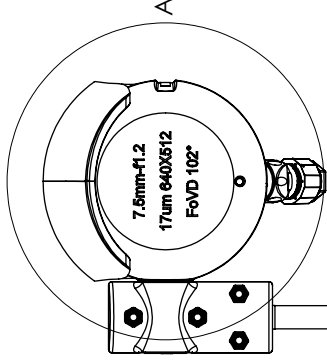

Extension tube
can rotate 360°

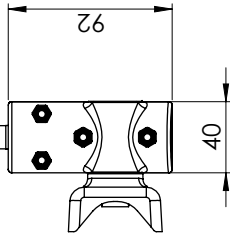

360° rotation possible

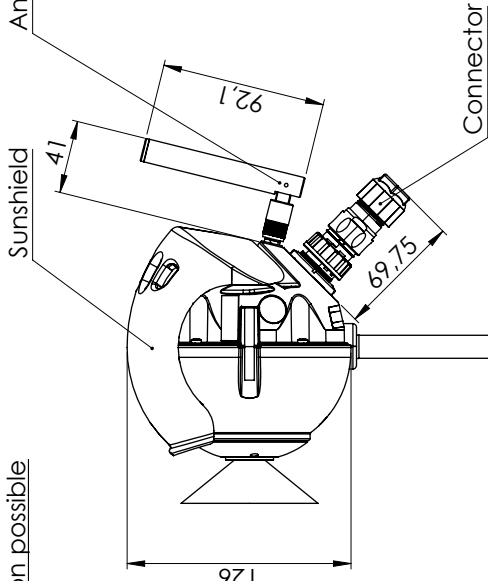

360° rotation possible

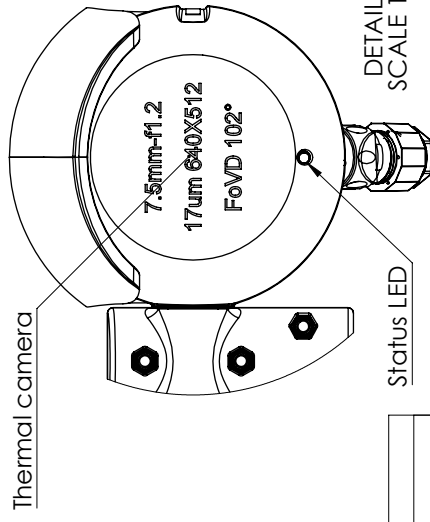
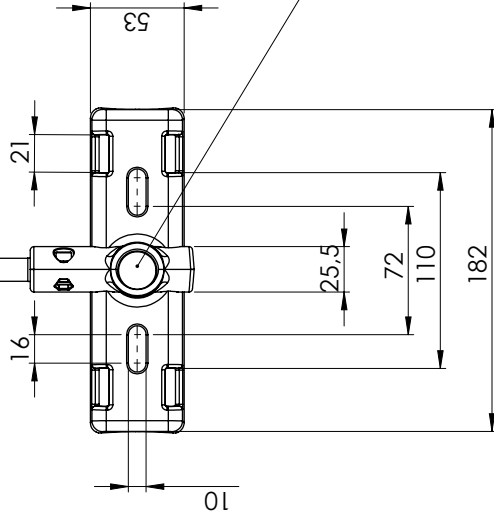
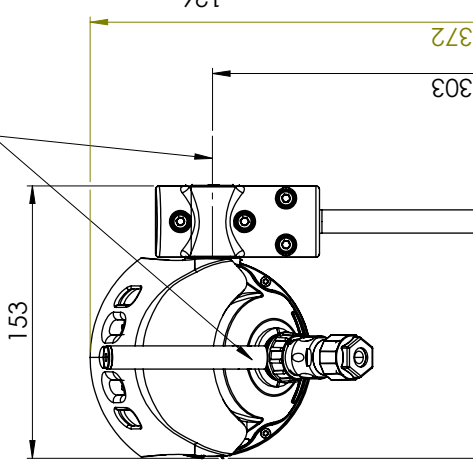

DETAIL A
SCALE 1 : 2

General remark:

- All screws can be fixed with hexagonal key 4
- The bracket can be fixed with cable ties or M8 bolts

AS	18/04/2023	XXXXXX	Additional dimension on customer request
AS	07/07/2022	01.00	Drawing for customer
Name	Date	Rev.	Description

General-Tolerance-DIN-ISO2768m-except-where-stated-NA

Linear dimensions		Radii		Angle	
From	0.5	3.0	6	30	120
To	3.0	6	30	120	4000
Tolerance	±0.1	±0.1	±0.2	±0.5	±0.15
					±0.2
					±1°

Material:	NA	Volume in mm ³ :	NA
Specifications:	NA	Weight in g:	<1 kg

Functional dimensions to check: (xxx) Dimensions in mm

General Quality Class: C	Exceptional Quality Class: A	Dimensions in mm
TITLE:		
ThermiCam AI Final Assembly		
DWG NO.: 10-77XX		

Projection: First angle	
Revision: SCALE:1:3	SHEET:1 OF 1
All rights strictly reserved. Reproduction or issue to third parties in any form whatever, is not permitted without written authority from FLIR.	

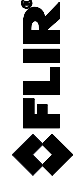

ITS - Hospitalweg 1B, B-8510 Marke

① TABLE LEGEND

- RED Fields : No practical solution - Physically impossible or non-realistic wire sections (>6mm²)
- OTHER Fields : Allowed options
- STAR TOPOLOGY
 - Practical wire section = Next higher commercial value of table value
 - Every sensor allowed to have different section according to table
- BUS TOPOLOGY
 - Practical wire section = Next higher commercial value of Worst table value x Number of sensors
 - Only single wire section for full bus cable length allowed
 - Product terminals do not support high wire gauges. Use junction box with branching cables
 - For sensor : Short (<10m) lower section (Bus section / # sensors) branch cables allowed
 - For TI BPL3 : Short (<1m) AWG16 equivalent cable allowed

TABLE REMARKS

- ⚠ Supply voltage of 48VAC not supported by all product versions
- Conductors are assumed to be copper below 60°C
- Cable length may be increased pro rata increasing conductor cross section up to 300m
- Cable with cross section above 1mm² / AWG18 may not fit directly to device
 - Use connection box for transition to sensor connector suitable adaption cable
 - Use short as possible adaption cables

COMMON CABLES					
METRIC			IMPERIAL		
Commercial Class	Wire Section (Table reference)	Commercial Class	Wire Section (Table reference)	Commercial Class	Wire Section (Table reference)
0.25	0.25 mm ²	AWG24	0.205 mm ²	AWG25	0.142 mm ²
0.50	0.50 mm ²	AWG22	0.326 mm ²	AWG23	0.258 mm ²
0.75	0.75 mm ²	AWG20	0.518 mm ²	AWG21	0.418 mm ²
1	1.00 mm ²	AWG18	0.823 mm ²	AWG19	0.653 mm ²
1.5	1.50 mm ²	AWG16	1.310 mm ²	AWG17	1.04 mm ²
2.5	2.50 mm ²	AWG14	2.081 mm ²	AWG15	1.65 mm ²
4	4.00 mm ²	AWG12	3.109 mm ²	AWG13	2.62 mm ²
6	6.00 mm ²	AWG10	5.260 mm ²	AWG11	4.17 mm ²

TI BPL3 Default Power Mode - RECOMMENDED CABLE Installation (Low Peak Cable loss – 15%)

POWER SUPPLY Simplified table	PEAK POWER (W) Any Voltage AC / DC	AVERAGE POWER (W) Any Voltage AC / DC	PSU Remarks
Interface + 1 Sensor	31	23	<u>Table Application:</u> <ul style="list-style-type: none"> Guaranteed stability: Power supply should be capable to deliver the calculated average power continuously in all conditions. Power calculation includes sensor and interface maximum consumption and cable losses PSU derating due to temperature must be taken into account Higher supply voltages are recommended for efficient power transmission. Recommended generic Power supplies
Interface + 2 Sensor	48	36	
Interface + 3 Sensor	65	48	
Interface + 4 Sensor	82	61	
Interface + 5 Sensor	99	73	
Interface + 6 Sensor	116	86	
Interface + 7 Sensor	133	99	
Interface + 8 Sensor	150	110	

Peak Power	Voltage	Watt	Volt	#	Length (m)										#					
					10	15	20	30	40	50	60	80	100	130		160	200	250	300	
ABSOLUTE MINIMUM WIRE SECTION PER SENSOR (mm²)																				
29	12VDC	1	0.897	1.301	1.735	2.402	3.470	5.137	7.204	10.760	15.826	23.493	34.760	51.427	76.493	112.160	169.826	256.493	1	
0		2	ABSOL	ABSOL	ABSOL	ABSOL	ABSOL	ABSOL	ABSOL	ABSOL	ABSOL	ABSOL	ABSOL	ABSOL	ABSOL	ABSOL	ABSOL	ABSOL	ABSOL	2
0		3	ABSOL	ABSOL	ABSOL	ABSOL	ABSOL	ABSOL	ABSOL	ABSOL	ABSOL	ABSOL	ABSOL	ABSOL	ABSOL	ABSOL	ABSOL	ABSOL	ABSOL	3
0		4	ABSOL	ABSOL	ABSOL	ABSOL	ABSOL	ABSOL	ABSOL	ABSOL	ABSOL	ABSOL	ABSOL	ABSOL	ABSOL	ABSOL	ABSOL	ABSOL	ABSOL	4
0		5	ABSOL	ABSOL	ABSOL	ABSOL	ABSOL	ABSOL	ABSOL	ABSOL	ABSOL	ABSOL	ABSOL	ABSOL	ABSOL	ABSOL	ABSOL	ABSOL	ABSOL	5
0		6	ABSOL	ABSOL	ABSOL	ABSOL	ABSOL	ABSOL	ABSOL	ABSOL	ABSOL	ABSOL	ABSOL	ABSOL	ABSOL	ABSOL	ABSOL	ABSOL	ABSOL	6
0		7	ABSOL	ABSOL	ABSOL	ABSOL	ABSOL	ABSOL	ABSOL	ABSOL	ABSOL	ABSOL	ABSOL	ABSOL	ABSOL	ABSOL	ABSOL	ABSOL	ABSOL	7
0		8	ABSOL	ABSOL	ABSOL	ABSOL	ABSOL	ABSOL	ABSOL	ABSOL	ABSOL	ABSOL	ABSOL	ABSOL	ABSOL	ABSOL	ABSOL	ABSOL	ABSOL	8
30	24VDC	1	0.081	0.121	0.162	0.242	0.323	0.404	0.485	0.646	0.808	1.050	1.292	1.615	2.015	2.423	3.015	3.808	1	
48		2	0.090	0.135	0.180	0.270	0.359	0.449	0.539	0.719	0.899	1.168	1.438	1.797	2.247	2.696	3.388	4.296	2	
62		3	0.101	0.152	0.203	0.304	0.405	0.506	0.608	0.810	1.013	1.316	1.620	2.025	2.532	3.038	3.858	4.878	3	
78		4	0.118	0.174	0.232	0.348	0.464	0.580	0.696	0.928	1.160	1.508	1.856	2.320	2.900	3.480	4.380	5.480	4	
93		5	0.138	0.204	0.271	0.407	0.543	0.679	0.814	1.066	1.357	1.764	2.171	2.714	3.393	4.071	5.071	6.271	5	
109		6	0.164	0.245	0.327	0.495	0.654	0.818	0.981	1.308	1.635	2.126	2.616	3.270	4.082	4.908	6.008	7.308	6	
0		7	ABSOL	ABSOL	ABSOL	ABSOL	ABSOL	ABSOL	ABSOL	ABSOL	ABSOL	ABSOL	ABSOL	ABSOL	ABSOL	ABSOL	ABSOL	ABSOL	7	
0		8	ABSOL	ABSOL	ABSOL	ABSOL	ABSOL	ABSOL	ABSOL	ABSOL	ABSOL	ABSOL	ABSOL	ABSOL	ABSOL	ABSOL	ABSOL	ABSOL	8	
30	48VDC	1	0.019	0.028	0.038	0.056	0.075	0.094	0.113	0.150	0.188	0.244	0.300	0.375	0.469	0.563	0.703	0.853	1	
48		2	0.019	0.029	0.038	0.058	0.077	0.096	0.115	0.154	0.192	0.250	0.308	0.384	0.480	0.577	0.727	0.887	2	
62		3	0.020	0.030	0.039	0.059	0.079	0.098	0.118	0.158	0.197	0.256	0.315	0.394	0.491	0.591	0.741	0.901	3	
78		4	0.020	0.030	0.040	0.061	0.081	0.101	0.121	0.162	0.202	0.261	0.321	0.404	0.505	0.606	0.756	0.916	4	
93		5	0.021	0.031	0.041	0.062	0.082	0.104	0.124	0.166	0.207	0.266	0.331	0.414	0.518	0.621	0.771	0.931	5	
109		6	0.021	0.032	0.043	0.064	0.085	0.106	0.128	0.170	0.213	0.273	0.338	0.425	0.530	0.633	0.783	0.943	6	
125		7	0.022	0.033	0.044	0.066	0.087	0.109	0.131	0.175	0.219	0.284	0.350	0.437	0.546	0.656	0.806	0.966	7	
141		8	0.022	0.034	0.045	0.067	0.090	0.112	0.135	0.180	0.225	0.292	0.359	0.449	0.562	0.674	0.824	0.984	8	
30	96VDC	1	0.012	0.018	0.024	0.036	0.048	0.060	0.071	0.095	0.119	0.155	0.191	0.238	0.298	0.357	0.448	0.539	1	
48		2	0.012	0.018	0.024	0.036	0.048	0.060	0.073	0.097	0.121	0.157	0.193	0.242	0.302	0.362	0.453	0.544	2	
62		3	0.012	0.018	0.025	0.037	0.049	0.061	0.074	0.098	0.123	0.160	0.196	0.246	0.307	0.368	0.459	0.550	3	
78		4	0.012	0.019	0.025	0.037	0.050	0.062	0.075	0.100	0.125	0.162	0.200	0.249	0.311	0.374	0.465	0.556	4	
93		5	0.013	0.019	0.025	0.038	0.051	0.063	0.076	0.101	0.127	0.165	0.203	0.253	0.317	0.380	0.471	0.562	5	
109		6	0.013	0.019	0.026	0.039	0.051	0.064	0.077	0.103	0.129	0.167	0.206	0.257	0.322	0.386	0.477	0.568	6	
125		7	0.013	0.020	0.026	0.039	0.052	0.065	0.078	0.105	0.131	0.170	0.209	0.262	0.327	0.392	0.483	0.574	7	
141		8	0.013	0.020	0.027	0.040	0.053	0.067	0.080	0.106	0.133	0.173	0.213	0.266	0.331	0.396	0.487	0.578	8	
30	24VAC	1	0.084	0.126	0.168	0.252	0.336	0.420	0.504	0.673	0.841	1.093	1.345	1.682	2.102	2.522	3.222	3.922	1	
47		2	0.094	0.141	0.188	0.282	0.376	0.470	0.564	0.752	0.940	1.221	1.504	1.880	2.349	2.819	3.589	4.359	2	
63		3	0.107	0.160	0.213	0.320	0.428	0.533	0.638	0.852	1.065	1.385	1.704	2.130	2.663	3.196	4.066	4.936	3	
80		4	0.123	0.184	0.246	0.369	0.492	0.615	0.738	0.961	1.229	1.598	1.967	2.459	3.071	3.683	4.683	5.683	4	
96		5	0.145	0.218	0.291	0.436	0.581	0.727	0.872	1.163	1.453	1.889	2.325	2.906	3.633	4.360	5.460	6.460	5	
110		6	0.166	0.249	0.332	0.504	0.664	0.824	0.984	1.300	1.616	2.080	2.544	3.208	3.972	4.972	5.972	7.172	6	
0		7	ABSOL	ABSOL	ABSOL	ABSOL	ABSOL	ABSOL	ABSOL	ABSOL	ABSOL	ABSOL	ABSOL	ABSOL	ABSOL	ABSOL	ABSOL	ABSOL	7	
0		8	ABSOL	ABSOL	ABSOL	ABSOL	ABSOL	ABSOL	ABSOL	ABSOL	ABSOL	ABSOL	ABSOL	ABSOL	ABSOL	ABSOL	ABSOL	ABSOL	8	
33	42VAC	1	0.027	0.040	0.053	0.080	0.106	0.133	0.159	0.213	0.266	0.346	0.425	0.532	0.640	0.797	1.000	1.203	1	
48		2	0.027	0.041	0.055	0.082	0.110	0.137	0.165	0.220	0.275	0.357	0.440	0.550	0.667	0.825	1.028	1.231	2	
65		3	0.028	0.043	0.057	0.085	0.114	0.142	0.171	0.228	0.285	0.370	0.456	0.570	0.712	0.854	1.057	1.259	3	
82		4	0.030	0.044	0.059	0.089	0.118	0.148	0.177	0.236	0.295	0.384	0.473	0.591	0.738	0.886	1.086	1.286	4	
99		5	0.031	0.046	0.061	0.092	0.123	0.153	0.184	0.245	0.307	0.399	0.491	0.613	0.767	0.920	1.120	1.320	5	
118		6	0.032	0.048	0.064	0.096	0.128	0.159	0.191	0.255	0.319	0.415	0.510	0.638	0.797	0.957	1.157	1.357	6	
133		7	0.033	0.050	0.066	0.100	0.133	0.166	0.199	0.266	0.332	0.431	0.532	0.664	0.830	0.997	1.197	1.397	7	
150		8	0.035	0.052	0.069	0.104	0.139	0.173	0.208	0.277	0.347	0.451	0.555	0.699	0.867	1.040	1.240	1.440	8	
33	84VAC	1	0.030	0.040	0.040	0.061	0.081	0.101	0.121	0.162	0.202	0.263	0.323	0.404	0.505	0.606	0.756	0.906	1	
48		2	0.021	0.031	0.041	0.062	0.083	0.104	0.124	0.166	0.207	0.269	0.331	0.414	0.518	0.622	0.772	0.922	2	
65		3	0.021	0.032	0.043	0.064	0.085	0.106	0.128	0.170	0.213	0.274	0.340	0.425	0.530	0.633	0.783	0.933	3	
82		4	0.022	0.033	0.044	0.066	0.087	0.109	0.131	0.175	0.219	0.284	0.350	0.437	0.546	0.656	0.806	0.956	4	
99		5	0.023	0.034	0.045	0.067	0.090	0.112	0.135	0.180	0.225	0.292	0.359	0.449	0.562	0.674	0.824	0.974	5	
118		6	0.023	0.035	0.046	0.069	0.092	0.116	0.139	0.185	0.231	0.301	0.370	0.462	0.578	0.694	0.844	0.994	6	
133		7	0.024	0.036	0.048	0.071	0.095	0.119	0.143	0.190	0.238	0.308	0.381	0.476	0.595	0.714	0.864	1.014	7	
150		8	0.025	0.037	0.049	0.074	0.098	0.123	0.147	0.196	0.245	0.319	0.393	0.491	0.613	0.736	0.886	1.036	8	

TI BPL3 Default Power Mode - ALLOWED CABLE Installation (High Peak Cable Loss –45%)

POWER SUPPLY	PEAK POWER (W)	AVERAGE POWER (W)	PSU Remarks
Simplified table	Any Voltage AC / DC	Any Voltage AC / DC	
Interface + 1 Sensor	40	24	<u>Table Application:</u> <ul style="list-style-type: none"> Guaranteed stability: Power supply should be capable to deliver the calculated average power continuously in all conditions. Power calculation includes sensor and interface maximum consumption and cable losses PSU derating due to temperature must be taken into account Higher supply voltages are recommended for efficient power transmission. Recommended generic Power supplies
Interface + 2 Sensor	67	40	
Interface + 3 Sensor	93	54	
Interface + 4 Sensor	119	70	
Interface + 5 Sensor	146	85	
Interface + 6 Sensor	172	100	
Interface + 7 Sensor	199	115	
Interface + 8 Sensor	206	124	

Peak Power (Watt)	Voltage (Volt)	#	Length (m)														#	
			10	15	20	30	40	50	60	80	100	130	160	200	250	300		
ABSOLUTE MINIMUM WIRE SECTION PER SENSOR (mm²)																		
29	12VDC	1	0.867	1.301	1.735	2.602	3.470	4.337	5.204	6.071	6.938	7.805	8.672	9.539	10.406	11.273	12.140	1
0		2	NA	NA	NA	NA	NA	NA	NA	NA	NA	NA	NA	NA	NA	NA	NA	2
0		3	NA	NA	NA	NA	NA	NA	NA	NA	NA	NA	NA	NA	NA	NA	NA	3
0		4	NA	NA	NA	NA	NA	NA	NA	NA	NA	NA	NA	NA	NA	NA	NA	4
0		5	NA	NA	NA	NA	NA	NA	NA	NA	NA	NA	NA	NA	NA	NA	NA	5
0		6	NA	NA	NA	NA	NA	NA	NA	NA	NA	NA	NA	NA	NA	NA	NA	6
0		7	NA	NA	NA	NA	NA	NA	NA	NA	NA	NA	NA	NA	NA	NA	NA	7
0		8	NA	NA	NA	NA	NA	NA	NA	NA	NA	NA	NA	NA	NA	NA	NA	8
39	24VDC	1	0.040	0.056	0.079	0.119	0.159	0.198	0.238	0.317	0.397	0.516	0.635	0.751	0.932	1.190	1.210	1
63		2	0.042	0.061	0.083	0.125	0.167	0.209	0.250	0.334	0.417	0.543	0.668	0.835	1.043	1.252	1.252	2
88		3	0.044	0.066	0.088	0.132	0.176	0.220	0.264	0.352	0.440	0.573	0.705	0.881	1.101	1.321	1.321	3
110		4	0.047	0.070	0.094	0.141	0.188	0.235	0.282	0.376	0.469	0.610	0.751	0.939	1.174	1.408	1.408	4
110		5	0.062	0.093	0.125	0.187	0.249	0.311	0.374	0.498	0.623	0.810	0.997	1.246	1.557	1.868	1.868	5
0		6	0.152	0.228	0.304	0.456	0.608	0.760	0.912	1.216	1.520	1.976	2.432	3.040	3.800	4.560	4.560	6
0		7	NA	NA	NA	NA	NA	NA	NA	NA	NA	NA	NA	NA	NA	NA	NA	7
0		8	NA	NA	NA	NA	NA	NA	NA	NA	NA	NA	NA	NA	NA	NA	NA	8
39	48VDC	1	0.010	0.014	0.019	0.029	0.038	0.048	0.057	0.076	0.096	0.124	0.153	0.191	0.239	0.287	0.287	1
63		2	0.010	0.015	0.019	0.029	0.039	0.048	0.058	0.077	0.097	0.126	0.155	0.194	0.242	0.290	0.290	2
88		3	0.010	0.015	0.020	0.029	0.039	0.049	0.059	0.078	0.098	0.127	0.157	0.196	0.245	0.294	0.294	3
112		4	0.010	0.015	0.020	0.030	0.040	0.050	0.059	0.079	0.099	0.129	0.159	0.198	0.248	0.297	0.297	4
137		5	0.010	0.015	0.020	0.030	0.040	0.050	0.060	0.080	0.100	0.131	0.161	0.201	0.251	0.301	0.301	5
161		6	0.010	0.015	0.020	0.031	0.041	0.051	0.061	0.081	0.102	0.132	0.163	0.203	0.254	0.305	0.305	6
186		7	0.010	0.015	0.021	0.031	0.041	0.051	0.062	0.082	0.103	0.134	0.165	0.206	0.257	0.309	0.309	7
209		8	0.011	0.016	0.021	0.032	0.042	0.053	0.063	0.084	0.105	0.137	0.168	0.210	0.263	0.315	0.315	8
39	80VDC	1	0.008	0.009	0.012	0.018	0.024	0.030	0.037	0.049	0.061	0.079	0.097	0.122	0.152	0.183	0.183	1
63		2	0.008	0.009	0.012	0.018	0.025	0.031	0.037	0.049	0.061	0.080	0.098	0.123	0.153	0.184	0.184	2
88		3	0.008	0.009	0.012	0.019	0.025	0.031	0.037	0.049	0.062	0.080	0.099	0.124	0.155	0.186	0.186	3
112		4	0.008	0.009	0.012	0.019	0.025	0.031	0.037	0.050	0.062	0.081	0.100	0.125	0.156	0.187	0.187	4
137		5	0.008	0.009	0.013	0.019	0.025	0.031	0.038	0.050	0.063	0.082	0.101	0.126	0.157	0.189	0.189	5
161		6	0.008	0.010	0.013	0.019	0.025	0.032	0.038	0.051	0.063	0.082	0.101	0.127	0.158	0.190	0.190	6
186		7	0.008	0.010	0.013	0.019	0.026	0.032	0.038	0.051	0.064	0.083	0.102	0.128	0.160	0.192	0.192	7
210		8	0.008	0.010	0.013	0.019	0.026	0.032	0.039	0.051	0.064	0.084	0.103	0.129	0.161	0.193	0.193	8
39	24VAC	1	0.041	0.062	0.082	0.124	0.165	0.206	0.247	0.330	0.412	0.536	0.659	0.824	1.030	1.236	1.236	1
65		2	0.043	0.065	0.087	0.130	0.174	0.217	0.261	0.348	0.435	0.565	0.695	0.869	1.086	1.304	1.304	2
90		3	0.046	0.069	0.092	0.138	0.184	0.230	0.276	0.368	0.460	0.597	0.735	0.919	1.149	1.379	1.379	3
110		4	0.050	0.075	0.100	0.150	0.200	0.249	0.299	0.399	0.499	0.648	0.798	0.998	1.247	1.496	1.496	4
110		5	0.071	0.106	0.142	0.213	0.284	0.355	0.426	0.567	0.709	0.922	1.135	1.419	1.773	2.128	2.128	5
110		6	0.266	0.399	0.532	0.798	1.064	1.330	1.596	2.128	2.660	3.458	4.256	5.320	6.760	8.190	8.190	6
0		7	NA	NA	NA	NA	NA	NA	NA	NA	NA	NA	NA	NA	NA	NA	NA	7
0		8	NA	NA	NA	NA	NA	NA	NA	NA	NA	NA	NA	NA	NA	NA	NA	8
40	42VAC	1	0.013	0.020	0.027	0.040	0.054	0.067	0.081	0.108	0.135	0.175	0.216	0.270	0.337	0.404	0.404	1
67		2	0.014	0.021	0.027	0.041	0.055	0.069	0.082	0.110	0.137	0.178	0.219	0.274	0.343	0.411	0.411	2
93		3	0.014	0.021	0.028	0.042	0.056	0.070	0.084	0.112	0.139	0.181	0.223	0.279	0.349	0.418	0.418	3
119		4	0.014	0.021	0.028	0.043	0.057	0.071	0.085	0.114	0.142	0.185	0.227	0.284	0.355	0.426	0.426	4
146		5	0.014	0.022	0.029	0.043	0.058	0.072	0.087	0.116	0.145	0.188	0.231	0.289	0.361	0.434	0.434	5
172		6	0.015	0.022	0.029	0.044	0.059	0.074	0.088	0.118	0.147	0.191	0.235	0.294	0.368	0.442	0.442	6
182		7	0.018	0.023	0.031	0.047	0.062	0.078	0.094	0.125	0.156	0.201	0.249	0.312	0.390	0.468	0.468	7
182		8	0.018	0.027	0.036	0.054	0.073	0.091	0.109	0.145	0.181	0.236	0.290	0.363	0.453	0.544	0.544	8
40	48VAC	1	0.010	0.015	0.021	0.031	0.041	0.051	0.062	0.082	0.103	0.134	0.164	0.206	0.257	0.308	0.308	1
67		2	0.010	0.016	0.021	0.031	0.042	0.052	0.062	0.083	0.104	0.135	0.167	0.208	0.260	0.312	0.312	2
93		3	0.011	0.016	0.021	0.032	0.042	0.053	0.063	0.084	0.105	0.137	0.169	0.211	0.264	0.316	0.316	3
119		4	0.011	0.016	0.021	0.032	0.043	0.053	0.064	0.086	0.107	0.139	0.171	0.214	0.267	0.321	0.321	4
146		5	0.011	0.016	0.022	0.033	0.043	0.054	0.065	0.087	0.108	0.141	0.173	0.217	0.271	0.325	0.325	5
172		6	0.011	0.016	0.022	0.033	0.044	0.055	0.066	0.088	0.110	0.143	0.176	0.220	0.275	0.330	0.330	6
199		7	0.011	0.017	0.023	0.033	0.045	0.056	0.067	0.089	0.111	0.145	0.178	0.223	0.278	0.334	0.334	7
206		8	0.012	0.018	0.023	0.035	0.047	0.059	0.070	0.094	0.117	0.153	0.188	0.235	0.293	0.352	0.352	8















Annex — About FLIR ITS’s AI process



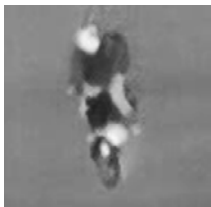

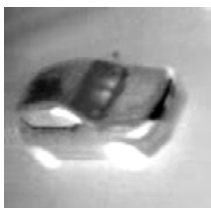







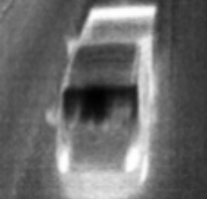
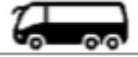
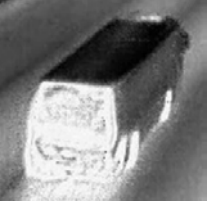

38.1 Compliance

FLIR’s AI processes are fully compliant with the EU AI act and GDPR regulations.

- FLIR ITS uses only images generated by its own cameras. No free internet-based datasets are being used to train the models.
- FLIR ITS has a fully controlled and proprietary AI model.
- Version control is in place for traceability purposes.
- AI process within a closed and controlled environment with restricted access management and management of model repository.
- Used data is anonymous. No image can be linked to an individual.
- FLIR ITS’s traffic cameras are closed and offline. No online or dynamic changes are made during operation of our products.
- Non generic solution: no new data is generated during operation.

38.2 AI classification reference icons and images

FLIR ITS object classification	Icon	Thermal images	
Person			
Bicycle			
Motorcycle			
Car			
Car with trailer		<p data-bbox="1074 1877 1230 1921">Mapped as “Car” classification</p>	

FLIR ITS object classification	Icon	Thermal images	
Van			
Van with trailer		<p data-bbox="1070 741 1230 797">Mapped as "Van" classification</p>	
Bus			
Small truck			
Large Truck			
Truck with trailer		<p data-bbox="1070 1648 1230 1704">Mapped as "Large Truck" classification</p>	
Cones	N/A	N/A	N/A
Boxes	N/A	N/A	N/A



Website

<http://www.flir.com>

Customer support

<http://support.flir.com>

Copyright

© 2024, FLIR Systems, Inc. All rights reserved worldwide.

Disclaimer

Specifications subject to change without further notice. Models and accessories subject to regional market considerations. License procedures may apply. Products described herein may be subject to US Export Regulations. Please refer to exportquestions@flir.com with any questions.

Publ. No.: ITS100050
Release: AK
Commit: 100468
Head: 100468
Language: en-US
Modified: 2024-11-15
Formatted: 2024-11-15