

instrAction
Pioneering
Water Filtration
Technology.

The most economical absorber resin
for PFAS and Metal Removal
from Water

January 2025

instrAction is a technology-driven developer of innovative water purification and process water recycling solutions.

COMPANY TIMELINE

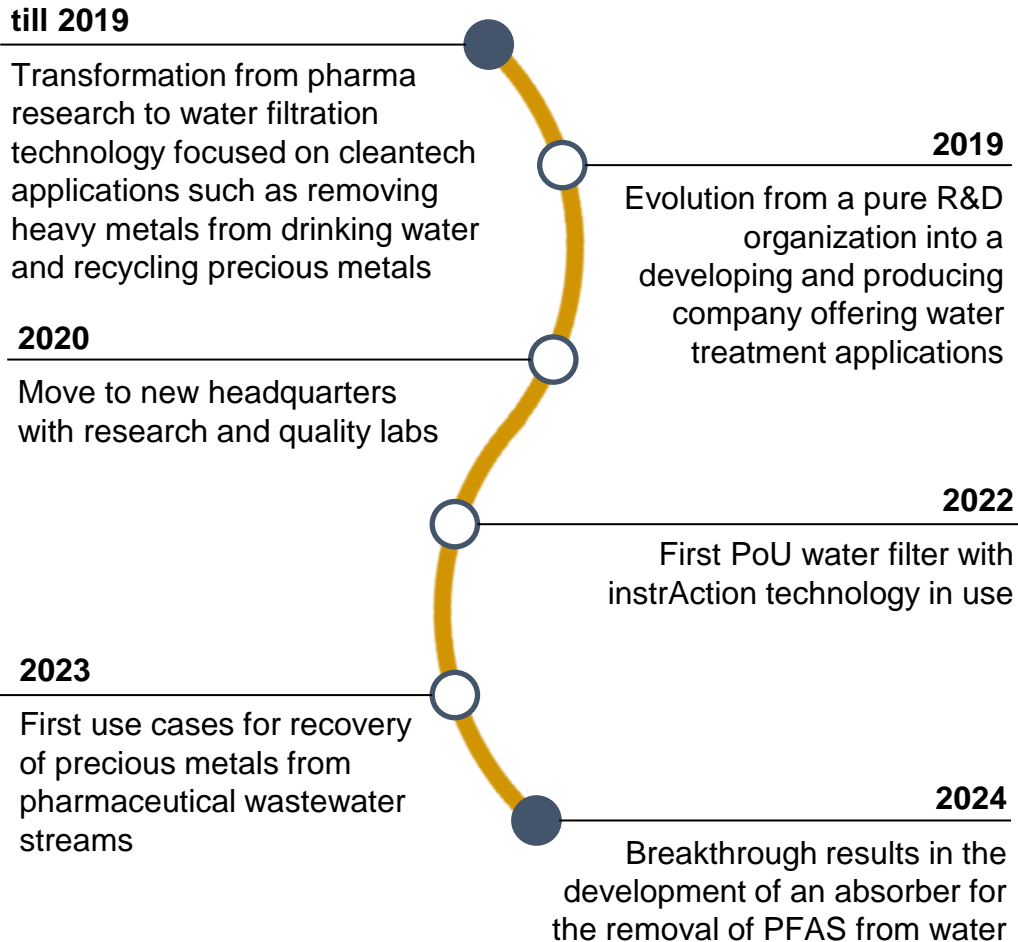

OVERVIEW



Proprietary platform technology based on absorber resins



headquartered in Heidelberg, Germany



10 employees



9 patent families
50 granted patents



Reliable manufacturing network in place

Problems in the chemical and water filtration industry.

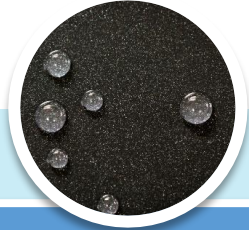

PFAS removal

Problem:

- Forever chemicals
- Environmental persistence
- Health risks
- Bioaccumulation
- Immune system impact

Need:

- Efficient and reliable water treatment solution
- Removal of short-and long-chain PFAS
- In accordance with legal standards.



Heavy metal removal

Problem:

- Impact on Water Quality
- Environmental Persistence
- Human Health Risks
- Bioaccumulation and Biomagnification
- Toxicity to Aquatic Life

Need:

- Efficient filtration system specific for the removal of heavy metals from effluents or drinking water according to legal limits.



Precious metal recovery

Problem:

- Resource depletion
- Environmental impact
- Health risks
- Inefficient recycling
- Economic loss

Need:

- Efficient recycling of heavy metals or precious metals from industrial aqueous or organic waste streams.



Point-of-Use water filtration

Problem:

- Bulky RO systems
- Effluent with concentrated contaminants



Need:

- Small but high-capacity dead end filtration system
- Save drinking water in mineral water quality straight from the tap.

The absorber resin with the most accessible and highest amount of binding sites.

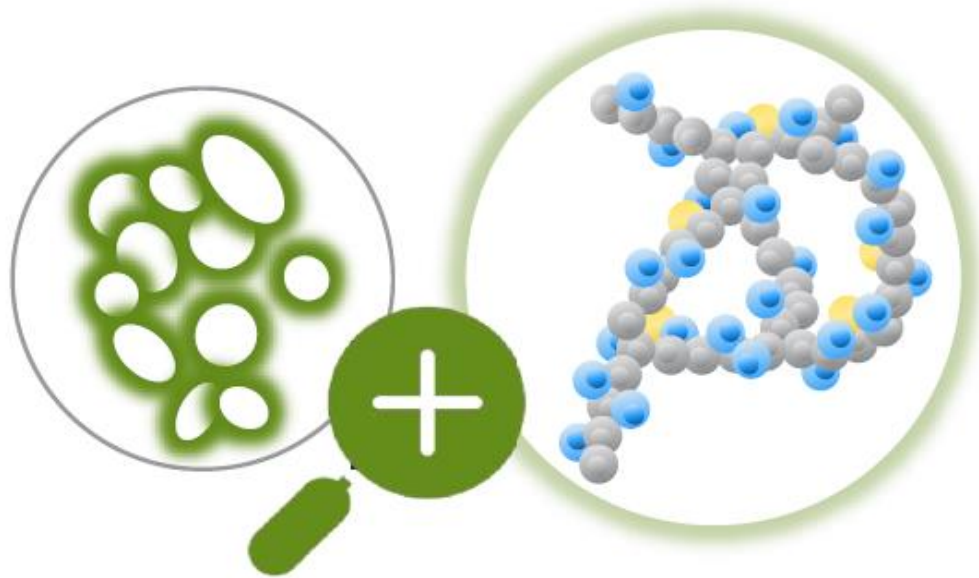
TECHNOLOGY PLATFORM



- 
Porous support
 A porous **support material** like silica gel or polystyrene is used as a basis for the absorber resin
- 
Polymer
 The porous support is covered with a chemically cross-linked **polymer network**
- 
Ligand(s)
 Different types of ligands (molecules that can bind to targets such as metal ions) can be attached to the polymer network that can be modified by type, number and ratio to achieve the desired filtration effect

BENEFITS & GENERAL ATTRIBUTES

- **High selectivity and high salt tolerance**
- **High physical and chemical stability**
- **Flow rates** above 1,000 BV/h can be processed
- **Reliable** depletion rate with high capacities and stable bindings
- Currently available mean **particle sizes** in µm: 50 | 200 | 425 | 1000

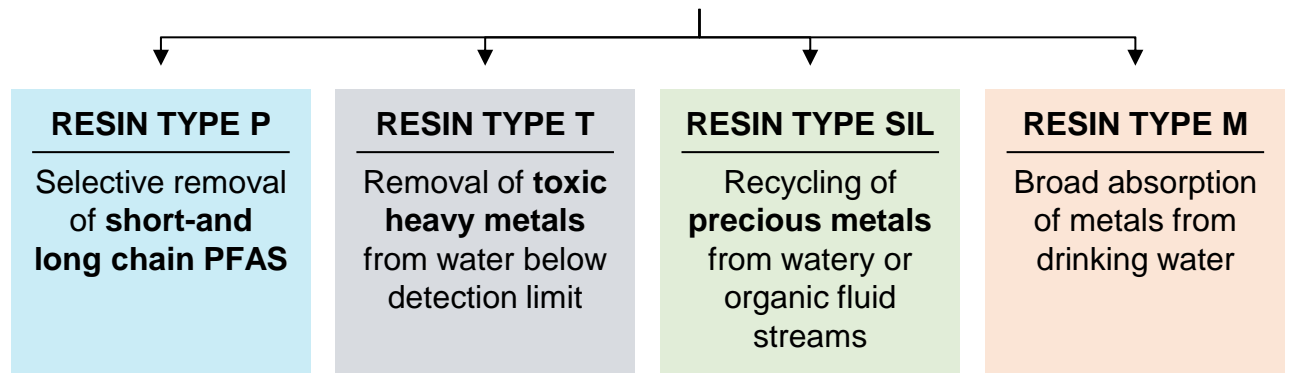

Typical water treatment process using instrAction absorber.

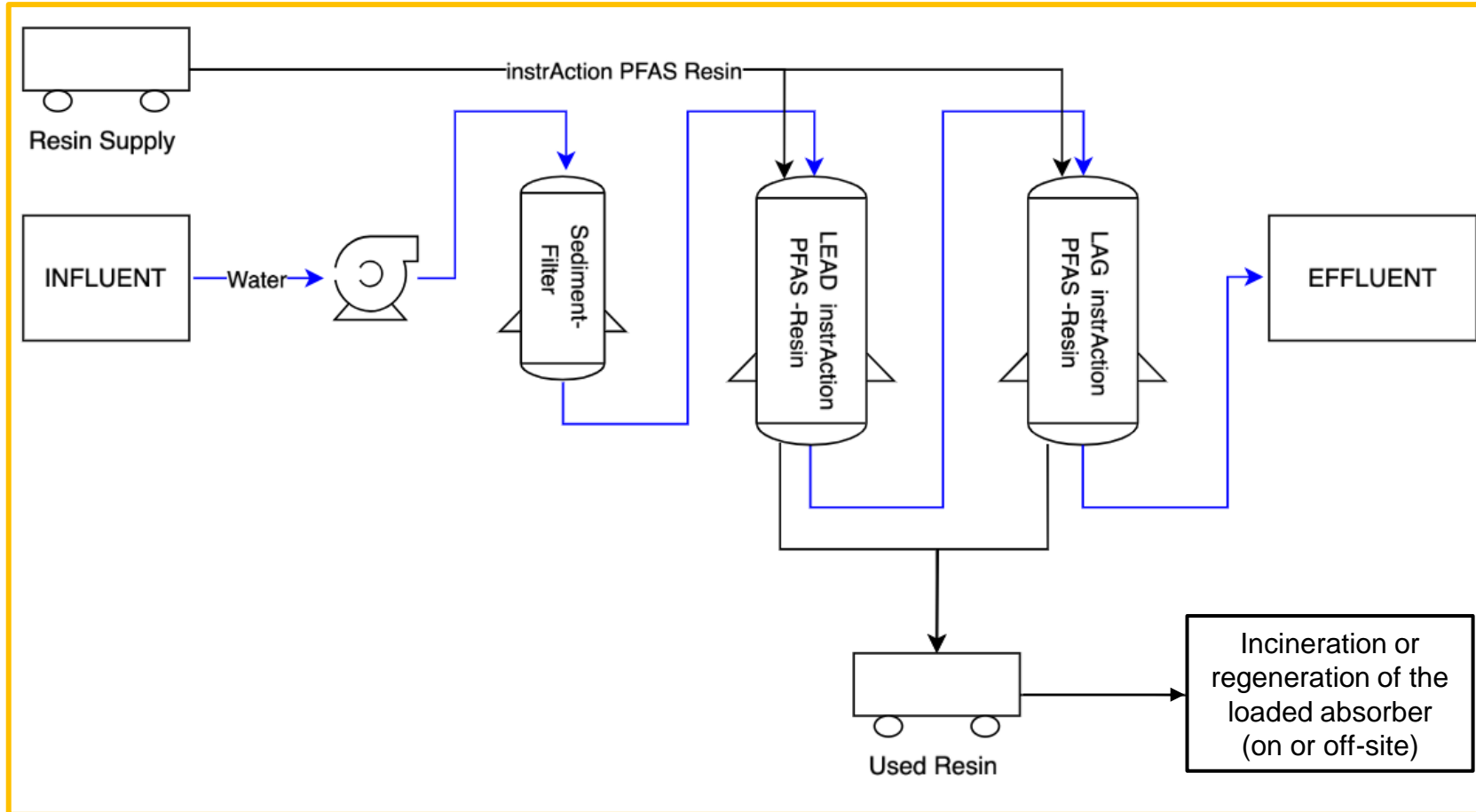

- Usage of off-the-shelf equipment known from water treatment processes using ion exchange resins or activated carbon.
- Reducing complexity through absorption and incineration in a single pass requires a high-performance absorber such as iA technology.
- Alternatively, the loaded absorber can be regenerated and reused.

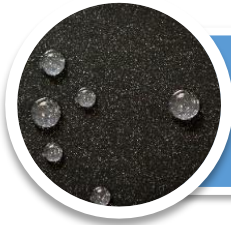

PFAS REMOVAL FROM WATER STREAMS

Selective removal and destruction of short- and long-chain PFAS

CONTAMINATED WATER



Contaminated water

- with short- or long-chain PFAS
- low or high concentrated

SEPARATION & CONCENTRATION



Easy filtration with iA absorber



DESTRUCTION OF PFAS FOREVER



Incineration of loaded absorber



Regeneration

Distillation
Destruction
electrochemical or catalytic oxidation, plasma

PFAS FREE ENVIRONMENT



PFAS free exhaust
Harmless Calcium fluoride



Harmless mineralized products like CO₂ and fluorides

The most economical way to get rid of PFAS forever.

Good alternative to destruct PFAS forever.

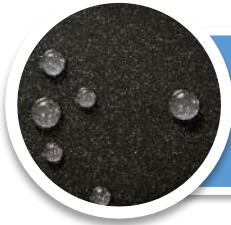

PFAS REMOVAL FROM WATER STREAMS

Benefits for operators of water treatment systems.

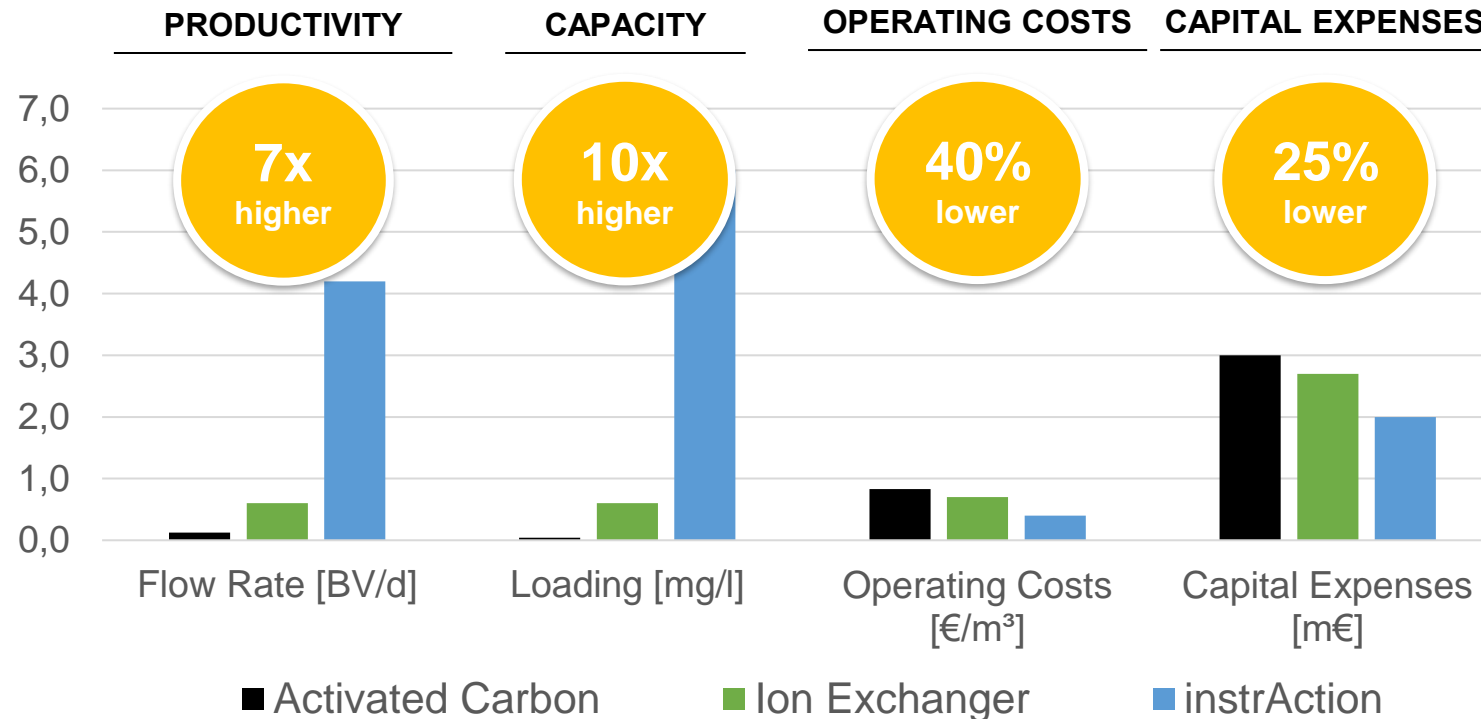

The high absorption efficiency leads to much lower operating costs and capital expenses compared to processes using state of the art technologies.



HEAVY METAL REMOVAL FROM FLUIDS

Efficient heavy metal removal from fluids - below legal limits for drainage or drinking water.

Lanxess TP207 vs. iA T425e
Industrial Effluent
Ni in 0,6 M NaCl

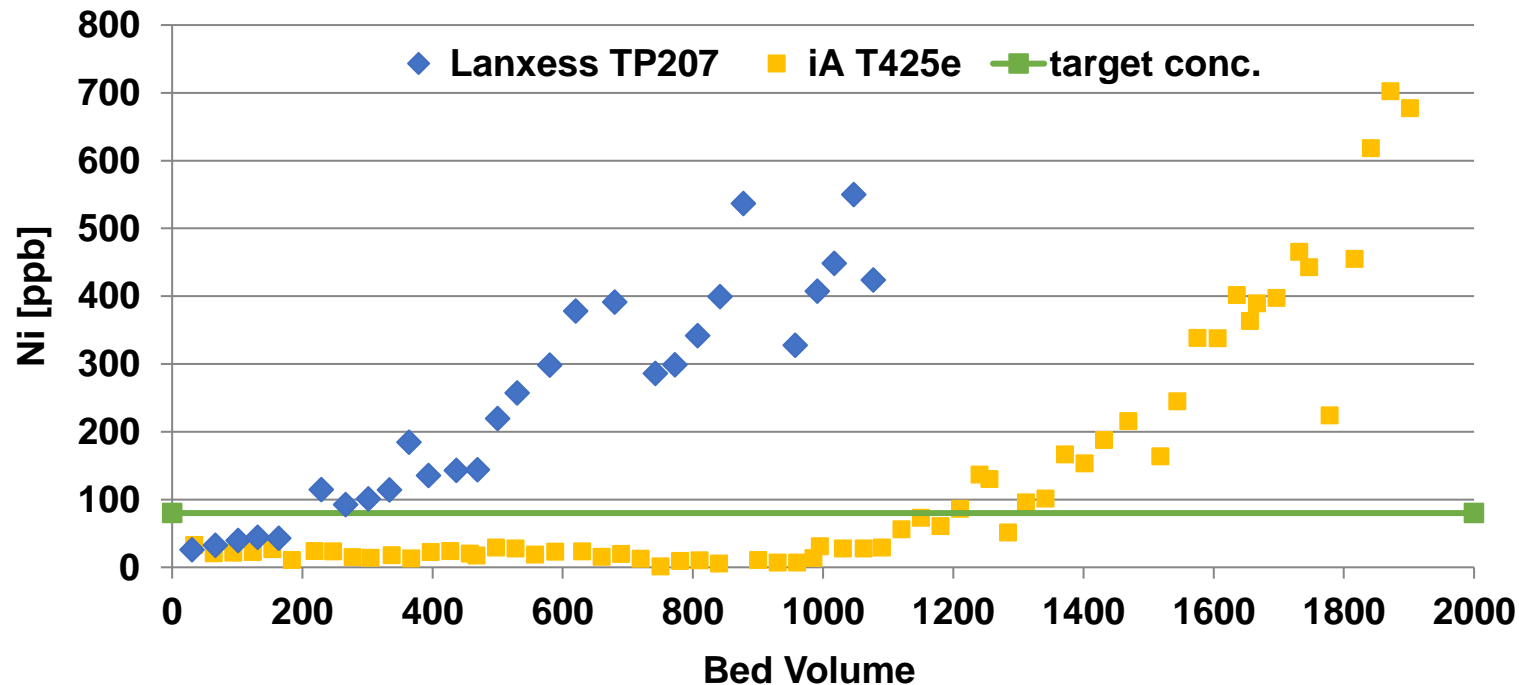

PRODUCTIVITY CAPACITY

3x
higher

5x
higher

- iA technology shows significant better performance compared to state-of-the-art ion exchange resins.
- proven for all relevant heavy metals.

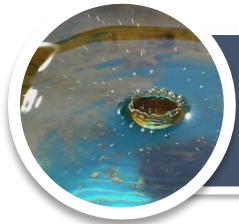

HEAVY METAL REMOVAL FROM FLUIDS

Efficient heavy metal removal from fluids - below legal limits for drainage or drinking water.

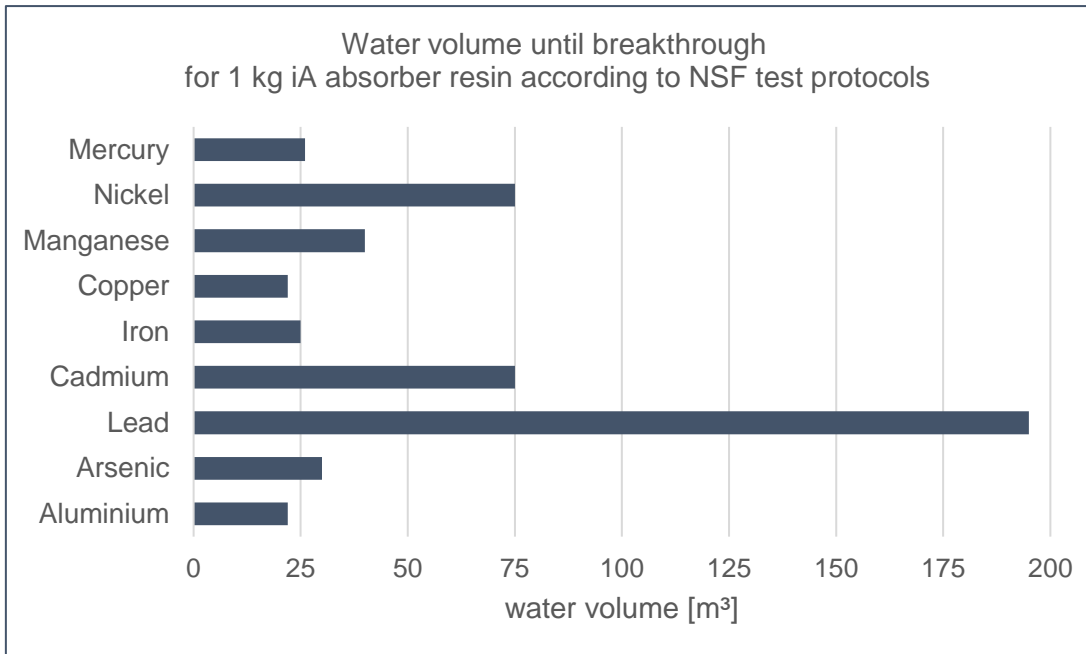

proved extractable metals

1																	2
H																	He
3	4											5	6	7	8	9	10
Li	Be											B	C	N	O	F	Ne
11	12											13	14	15	16	17	18
Na	Mg											Al	Si	P	S	Cl	Ar
19	20	21	22	23	24	25	26	27	28	29	30	31	32	33	34	35	36
K	Ca	Sc	Ti	V	Cr	Mn	Fe	Co	Ni	Cu	Zn	Ga	Ge	As	Se	Br	Kr
37	38	39	40	41	42	43	44	45	46	47	48	49	50	51	52	53	54
Rb	Sr	Y	Zr	Nb	Mo	Tc	Ru	Rh	Pd	Ag	Cd	In	Sn	Sb	Te	I	Xe
55	56	71	72	73	74	75	76	77	78	79	80	81	82	83	84	85	86
Cs	Ba	Lu	Hf	Ta	W	Re	Os	Ir	Pt	Au	Hg	Tl	Pb	Bi	Po	At	Rn
57	58	59	60	61	62	63	64	65	66	67	68	69	70				
La	Ce	Pr	Nd	Pm	Sm	Eu	Gd	Tb	Dy	Ho	Er	Tm	Yb				
89	90	91	92	93	94	95	96	97	98	99	100	101	102				
Ac	Th	Pa	U	Np	Pu	Am	Cm	Bk	Cf	Es	Fm	Md	No				

iA technology shows high loading capacity for heavy metals according to NSF 53 test requirements.

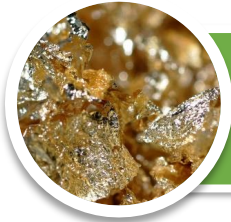

PRECIOUS METAL RECOVERY FROM FLUIDS

Value creation with instrAction's knowledge and absorber technology.

**STANDARD
RECYCLING RATE**

VALUE CREATION

**TARGET
RECYCLING RATE**



USE CASES CONFIRM EFFICIENCY OF iA TECHNOLOGY

Palladium removal

Source: Pharma waste stream
Savings: 1.5m € per campaign

Iridium removal

Source: Industrial waste stream
Savings: 12m € per year



POINT-OF-USE AND POINT-OF-ENTRY WATER FILTRATION

OEM solutions from instrAction



ULTIMATE FILTER

- iA owned design
- Slim, smart, elegant design
- Fits under each sink



ALL IN ONE 10" FILTER

- Standardized Design
- Replacement cartridge fits in most 10" housings



MULTI STEP FILTRATION

- Modular filter system
- Substitutes RO-Systems at PoU



filbec®

- Relies on iA technology
- Launched in 2024



Tested and Certified by WQA against NSF/ANSI/CAN 61

Filtered water with mineral water like quality but compact and easy to use.

Products and infrastructure are established and ready to serve the markets.

IA ABSORBER



Ready for commercialization

LABORATORY

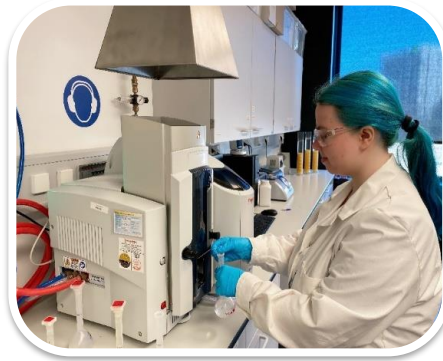

Established R&D and QA



Service Analytic for PFAS and Metals

MANUFACTURING

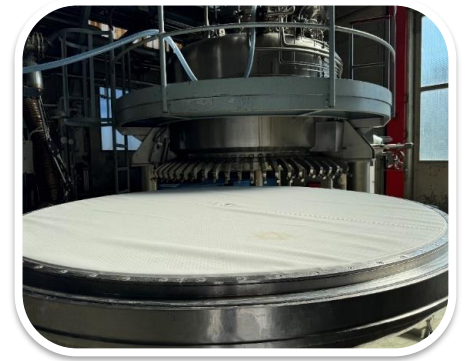

Capacity of more than 10 tons per day

PILOTS



Demo plant



Ni removal



PFAS removal

Let's create a future with clean and safe water for all.

instrAction GmbH

Carl-Friedrich-Gauß-Ring 5

69124 Heidelberg

T +49 6221 6509946

info@instraction.de

www.instraction.de



Follow us



Supported by:



on the basis of a decision by the German Bundestag



Florian Rohde

Managing Director

florian.rohde@instraction.de

M +49 171 2207907



Mohnish Pujari

Business Development Manager

mohnish.pujari@instraction.de

M +49 170 9471066