

Electric boiler for the emergency reserve market FCR-D

- Electric boiler for the frequency-controlled emergency reserve market
- The device supports FCR-D- markets down and up
- For both dynamic and static use: The device monitors the current message of the external provider.
- Models 150-1600 kW
- Power steps 0-15
- Four control methods:
 - 1) Emergency reserve use, i.e. SG
 - 2) Outdoor temp. control* + SG
 - 3) Target temperature control* + SG
 - 4) External control + SG
- Works with flow-through technology and requires an external circulation pump to ensure the circulation of water through the boiler
- Comprehensive remote monitoring and control possibilities through building automation (e.g. Modbus TCP/RTU)
- Safety features built in



FCR-D



Jäspi FIL SG is a device that can be used to participate in Fingrid's FCR-D market.

The device is primarily an electric boiler made for emergency reserve market use (it also works like a normal electric boiler). Jäspi FIL SG can be connected to various heating systems.

The property's electricity connection and water volume must be large enough, min. 30 min** for storing/unloading the amount of energy/power corresponding to the disturbance situation.

* Option to adjust the heating curve with external stock exchange control

** Information according to 04/2024, Fingrid

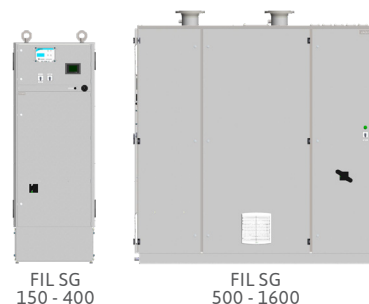

Technical information Jäspi FIL SG 150-400 (medium frame)	
Rated voltage, models 150-400	400 V 3 PE AC 50 Hz
Control unit voltage*	230 V 1 N AC 50 Hz
Dimensions H x W x D	1900 x 700 x 855 mm
Power steps	0-15
Pipe connections	DN 100
IP-class	IP 20
Ambient temperature	5...25 °C
Max temperature	110 °C
Max pressure	10 bar
Operating temperature (electric boiler)	10...99 °C

Built-in safety features
Safety main switch
Temperature limiter
Dry boiling limiter
Standby use with thermostat
Internal temperature monitoring and limiting
Alarm outputs and fault diagnostics
System pressure range monitoring
Sensor values min. and max. control

Technical information Jäspi FIL SG 500-1600 (large frame)	
Rated voltage	400 V 3 PE AC 50 Hz
Control unit voltage*	230 V 1 N AC 50 Hz
Dimensions H x W x D (500-800)	1800 x 2022 x 1150 mm
Dimensions H x W x D (900-1200)	2000 x 2022 x 1150 mm
Dimensions H x W x D (1500-1600)	2400 x 2022 x 1150 mm
Power steps	0-15
Pipe connections	DN 125
IP-class	IP 20
Ambient temperature	5...25 °C
Max temperature	110 °C
Max pressure	10 bar
Operating temperature (electric boiler)	10...99 °C

* Separate supply with control voltage.

The technical information on the other side of the product card changes depending on the model.

Jäspi FIL SG 150-400 and 500-1600

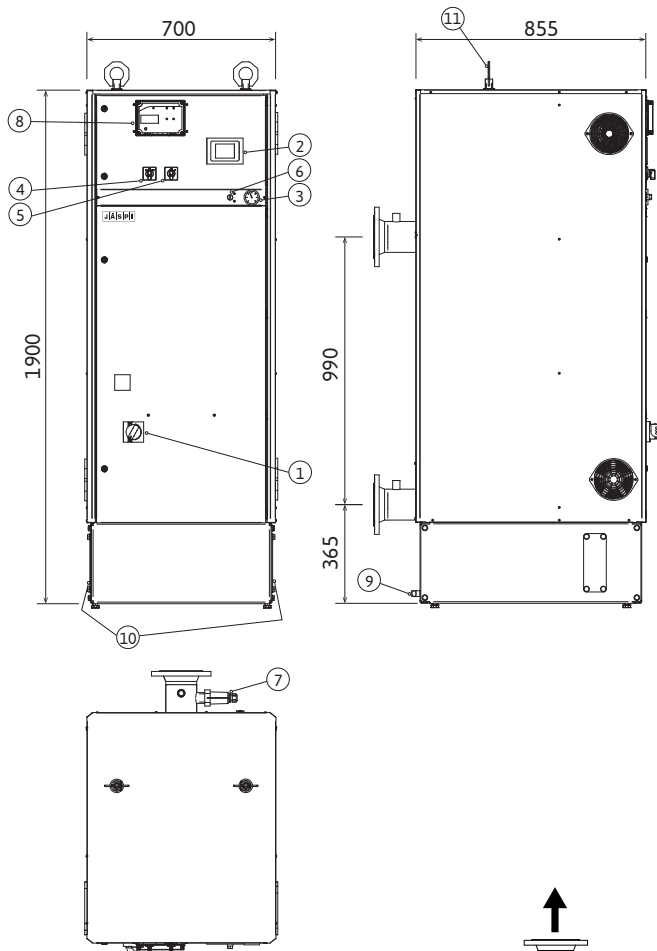

Model / power [kW]	Weight empty	Recommended fuse [A]	Liquid volume
150	350	3 x 250	220
180	350	3 x 315	220
225	350	3 x 400	220
260	350	2 x (3 x 250)	220
300	350	2 x (3 x 250)	220
340	350	2 x (3 x 315)	220
360	350	2 x (3 x 315)	220
400	350	2 x (3 x 400)	220
500	950	2 x (3 x 500)	480
600	950	2 x (3 x 630)	480
700	950	2 x (3 x 630)	480
800	950	3 x (3 x 500)	480
900	1350	3 x (3 x 630)	750
1000	1350	3 x (3 x 630)	750
1100	1350	3 x (3 x 630)	750
1200	1350	4 x (3 x 630)	750
1300	1500	4 x (3 x 630)	1000
1400	1500	4 x (3 x 630)	1000
1500	1500	4 x (3 x 630)	1000
1600	1500	4 x (3 x 630)	1000

Parts: FIL SG 150-400

1. Safety main switch
2. Control unit
3. Temperature gauge
4. Control voltage switch
5. Normal/standby mode selector switch
6. Temperature limiter
7. Dry boiling limiter sensor
8. Dry boiling limiter
9. Drain connection 1/2" et
10. Space reservation for the entry of electrical cables
11. Lifting point

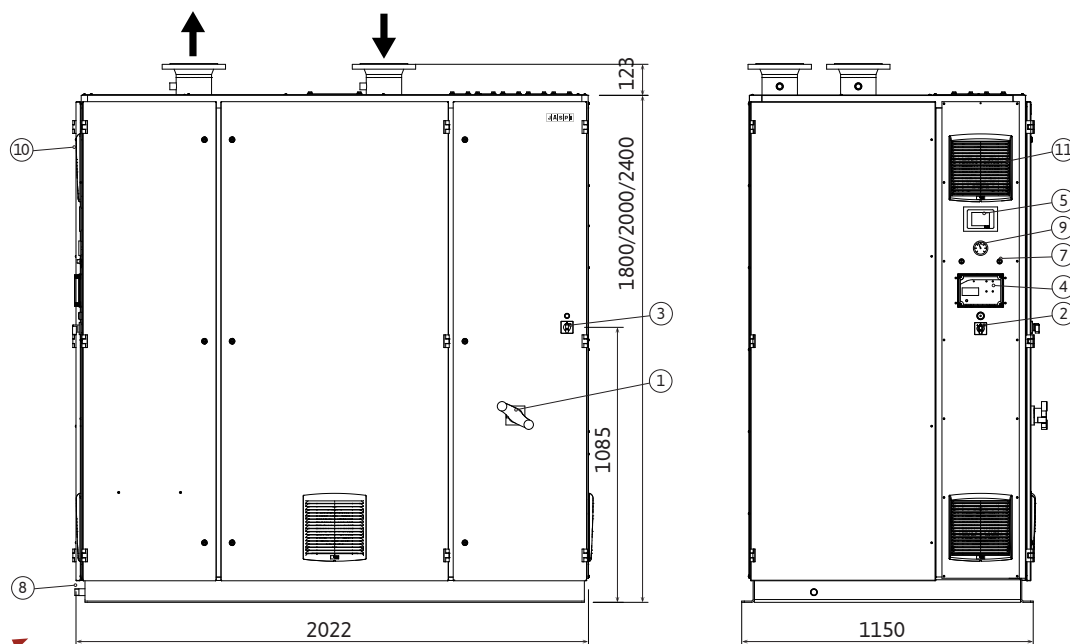

Parts: FIL SG 500-1600

1. Safety main switch
2. Normal/standby mode selector switch
3. Control voltage switch and indicator light
4. Dry boiling limiter
5. Control unit
6. Space reservation for electricity supply
7. Temperature sensors for limiters
8. Drain connection 3/4" et
9. Temperature gauge
10. Door for maintenance of electric heating elements
11. Electric space fans

